



3C·VaCS

**The 3C-VaCS project:
competitive chemical value
chains in the Netherlands-
Flanders- North Rhine-Westphalia
chemical cluster**

May 2026



The Netherlands

North Rhine-Westphalia

Flanders

IMPRINT

AUTHORS

Alexandra Göbel, DECHEMA e.V.

Flore Verbist (PhD student), KULeuven, VITO/Energyville

Florian Ausfelder, DECHEMA e.V.

Hans Van de Put, VITO/Energyville

Joris Valee, VITO/Energyville

Mariia Merko, DECHEMA e.V.

Negar Namazifard (PhD student), KULeuven, VITO/Energyville

Pieter Vingerhoets, VITO/Energyville

Sabrina Müller, DECHEMA e.V.

Timo Imhof, DECHEMA e.V.

With support of TNO (Chapter 3.1, Annex E-H and data collection for Chapter 2.2.1)

Frank Wubbolts, Marcelle Senekal, Tonny Manalal

CONTACTS

VITO/Energyville

Joris Valee joris.valee@vito.be

DECHEMA Gesellschaft für Chemische Technik und Biotechnologie e.V.

Sabrina Müller sabrina.mueller@dechema.de

Responsible for content under the terms of press legislations

DECHEMA e.V.

Dr. Florian Ausfelder

Theodor-Heuss-Allee 25

60486 Frankfurt am Main

Germany

VITO/EnergyVille

Communications@energyville.be

Thorpark 8310

3600 Genk

Belgium

DOI: 10.5281/zenodo.19878077

All rights reserved

© 3C-VaCS Project, 05/2026

ACKNOWLEDGEMENTS

We gratefully acknowledge the Flemish government for funding the research at Vito EnergyVille and the government of North Rhine-Westphalia as well as Verband der Chemischen Industrie Nordrhein-Westfalen (VCI NRW) for funding the research at DECHEMA e.V.

We further want to thank all people involved in this study. Your contributions have significantly improved this work and we greatly appreciate your support, fruitful discussions and provided feedback:

- The members of the Executive Board: Astrid Volckaert, Benjamin Dupont, Lisanne Blom, Jan-Peter Hinterlang, Colette Alma, Mark Schmets, Wouter Jongepier, and Janine van Kampen;
- The members of the Sounding Board: Eric ter Hark, Chiara Coffano, Florie Gonsolin, Klaus Ulrich Schäfer, Jörg Rothermel, Nico van Dooren, Ton van Dril, and Liesbeth Stockman;
- All industry representatives who participated in our interviews and workshops.



EXECUTIVE SUMMARY

The Trilateral Chemical Region (TCR) – the Netherlands, Flanders in Belgium and North Rhine-Westphalia in Germany – is a unique region of strategic importance for the European industry.

As a backbone of industrial value chains, the chemical industry enables the production of virtually all modern goods. About 1,300 chemical companies of various sizes are located within the TCR, employing about 200,000 people directly in the region. A special characteristic of the TCR is its high concentration of integrated chemical parks (so-called *Verbund* sites): more than 20 of them are located in the TCR, demonstrating an exceptional degree of industrial interconnection. These sites enable close linkages between producers and consumers of chemicals, often hosting entire value chains within a single industrial complex. This integration improves cost efficiency through shared infrastructure, optimised logistics, and the joint use of resources, services, by-products, and energy. Furthermore, the TCR benefits from an exceptionally well-developed infrastructure network: world-scale harbours, extensive pipeline systems, international waterways, and a high density of railways and roads allow for efficient logistics required by the industry.

Despite national differences, the industries within the TCR operate as a cohesive system. This is particularly evident in the integrated steam cracker value chain and its products which are actively traded across the region as well as cross-border and beyond resulting in a high level of cross-border interdependence.

TRILATERAL CHEMICAL REGION (TCR)

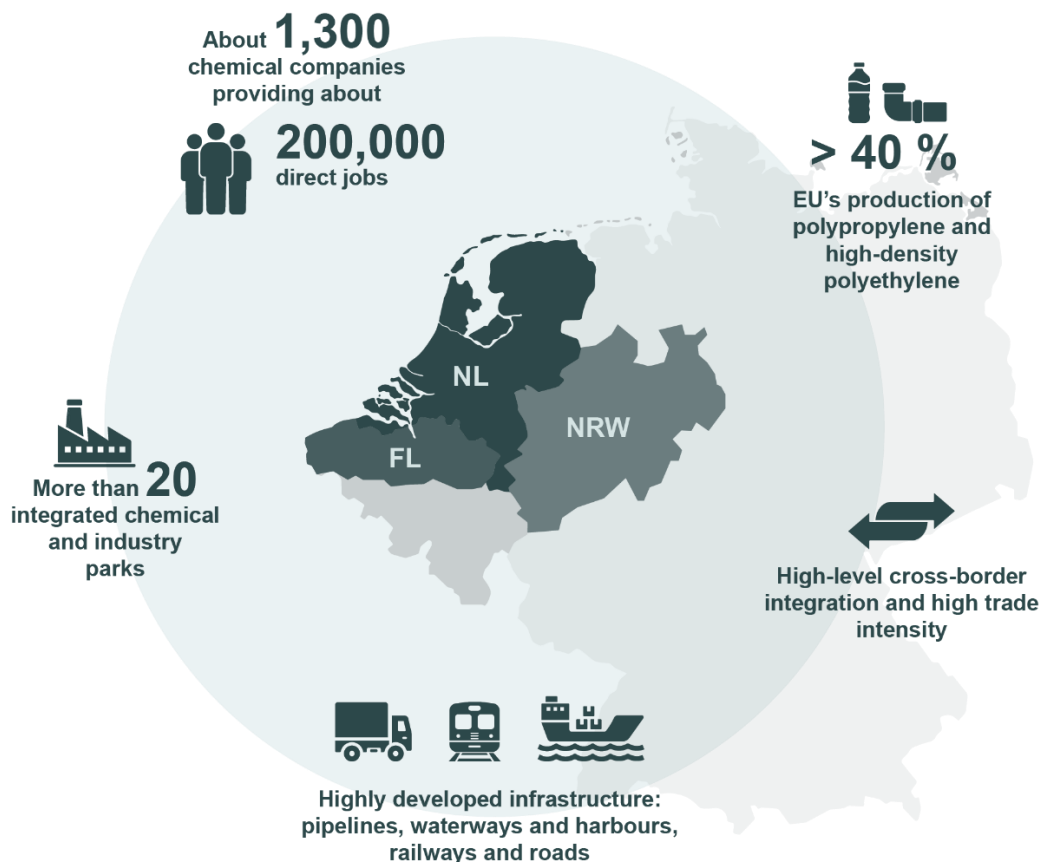



TCR steam crackers remain central to Europe's industrial base, but output has fallen sharply during the recent crisis.

Steam cracker products such as ethylene, propylene and butadiene serve as the building blocks for numerous polymers essential to sectors such as automotive manufacturing, healthcare, defense, renewable energy and everyday consumer goods.

The TCR functions as a key hub for European polymer production, accounting for approx. 42 % of Europe's total steam cracker capacity as of January 2026. More than 40 % of Europe's high-density polyethylene and polypropylene originate from the TCR.

Since 2019, olefin production in the TCR has seen a continuous decline with steam crackers being operated well below an aspired capacity utilisation rate of 95 %. The strongest decrease in the steam cracker utilisation rates occurred after the energy crisis with increased energy and feedstock prices caused by Russia's war on Ukraine in 2022.

Today, the European chemical industry is under intense global pressure, and the TCR is no exception.

The ongoing industry crisis driven by high energy, climate, regulation and production costs, as well as global overcapacities, and weak domestic demand have affected companies across the entire chemical sector. The chemical industry is highly dependent on downstream sectors such as the automotive and building industry, which have seen a recession over the past years. Being Europe's powerhouse for polymer production, this weakened European demand has hit the TCR particularly hard. As a result, many companies in the region have announced strategic portfolio reviews resulting in plant closures and project cancellations. The closure of individual facilities at integrated industrial sites cannot be viewed in isolation. While some closures have minor effect that can easily be overcome e. g. by switching to other customers or suppliers, others pose existential threats to players up and down the value chain due to strong interdependencies. Which plants are crucial for other companies' production is hard to evaluate from the outside as they depend on a multitude of factors such as infrastructural bottlenecks, a company's internal supply chain structure and individual pricing. Nevertheless, Europe urgently needs to identify and secure critical chemical production vital to its industrial resilience. For steam crackers, announced shutdowns account for 17 % of the total ethylene capacity within the TCR but will be – in terms of ethylene production – fully compensated by a newly commissioned steam cracker coming online in 2026. Since the new cracker is designed for ethane as feedstock, it will produce only a limited amount of other regular steam cracking products. It remains to be seen if ethylene production capacities will stabilise or further closures will follow.

Over the past two decades, the EU27's share of global chemical sales has declined sharply, reflecting the growing dominance of Asian producers in the market. China, in particular, has emerged as a major industrial force, holding a substantial trade surplus in fine and specialty chemicals and ranking as the largest source of chemical imports to the EU27 in 2024. This development has raised concerns about market distortions, including an influx of possibly subsidised low-cost imports and potential unfair competition for European producers. However, our analysis on olefins and polymers in their primary forms does not show that China exported significantly more of these chemicals to the TCR than it imported from the region in 2024. For some polymers in primary form, the TCR was actually a net exporter to China and not the other way around. The large-scale import of plastic-made consumer products from China, however, indirectly affects the European chemical industry by reducing local demand from manufacturers of consumer goods.

In addition, global market dynamics such as US trade policies are further increasing the pressure on the European chemical industry's competitive position. While the US have been an important export market in the past, it is unclear if other regions can absorb the products that were directed towards the



US market. On the other hand, the EU could become the destination for redirected export flows from other countries, comprising goods no longer purchased by US companies or consumers. This would further weaken the demand for domestically produced chemicals.

In addition to global political disruptions, the European chemical industry faces structurally higher production costs than competitors in other regions, largely due to elevated energy prices and CO₂ costs. This creates a significant global competitive disadvantage. As the industry depends on crude oil and natural gas both as feedstocks and energy sources, the production cost gap has widened further since 2022. Given its high energy intensity, the chemical sector is particularly affected by this disadvantage.

In light of this, it is not surprising that most major projects in the TCR, that have recently started or are close to completion were approved before 2022. New large-scale investments now appear more challenging, and strategic portfolio reviews may identify regions outside of Europe as more attractive in terms of feedstock and energy costs.

The TCR is characterised by high-intensity local trade and by being an important supplier of polymers to the European market. The crisis becomes visible in the trade flows.

For the analysed commodities along the steam cracker value chain (olefins and polymers in primary forms), the intensity of two-way trade is particularly strong at the TCR level. This highlights the vital role of a highly integrated infrastructure network within the region to enable this trade and the high interconnectivity within the cluster.

In recent years, the TCR has acted as a net exporter of polymers, with production serving both external markets and local demand. The largest export volumes of polymers such as polyethylene, polypropylene and polyvinyl chloride produced in the TCR go to other European countries. This underscores both the significance of the domestic European market for the TCR, as well as the importance of the TCR-based chemical production for the customers across Europe. In terms of olefins trade, the TCR was a net importer with notable differences between countries: Belgium imported large volumes of ethylene and propylene, while the Netherlands remained a significant net exporter. Since steam cracker products are mostly traded within regional markets, reduction of the steam cracker capacities is not expected to lead to higher imports of ethylene or propylene but result in increased imports of the downstream products. On the other hand, some products of Europe's steam crackers, such as benzene and C4, are also attractive for non-European countries: regions like the Middle East or the US mostly crack ethane based feedstocks which mostly yield ethylene but are lacking the other products obtained from cracking naphtha.

Since 2019, the overall chemical trade activity in the TCR has weakened, with declines in both imports and exports. This general downturn, particularly visible in polymer net exports from North Rhine-Westphalia, can be attributed to lower local demand and reduced demand in the rest of Germany.

STEAM CRACKER VALUE CHAIN IN THE TCR

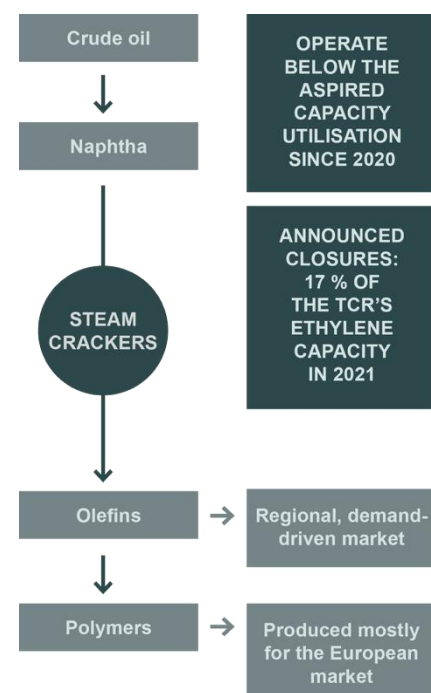



Dependence on imports of ammonia and methanol, important bulk commodities for the chemical industry, increases geopolitical vulnerability and highlights the need for diversification.

In 2019-2024, the TCR was a net importer of two bulk chemicals, ammonia and methanol, which were mostly imported from a few non-European countries, of which some have become subject to geopolitical tensions with the EU. Whereas imported ammonia was mainly consumed domestically, methanol was largely re-exported by Belgium and the Netherlands, highlighting the role of the major ports in the TCR as key transit hubs for this commodity. The reliance on only few critical trade partners, combined with an unstable geopolitical environment and a continuing trend to use economic dependency as a political tool to exert pressure, highlights the need to maintain strategic production capacities, develop diversification strategies, and ensure infrastructure that enables a rapid shift to alternative suppliers to prevent coercion.

Future value chains: bio-based ethylene remains costly by 2030, but low-carbon and CCS pathways may achieve cost parity by mid-century through rising carbon prices and negative emission revenues. Nevertheless, long-term viability will depend on how these technologies perform in international competition, which remains a decisive factor for investment and market uptake.

Having analysed the current steam cracker value chain, this study models alternative pathways for future production of one of its key basic output chemicals, ethylene. Several scenarios were explored, including methanol-to-olefins (MTO), bio-based naphtha, electrification, carbon capture and storage (CCS) integration, and plastic waste-derived production routes.

By 2030, fully bio-naphtha-based ethylene production remains one of the most expensive options, at 2,664 EUR per tonne of ethylene, primarily due to high costs of EU-imported biomass-based naphtha. The implementation of carbon dioxide removal (CDR) rewarding is currently under discussion at EU level. In contrast, ethane cracking with CCS emerges as the lowest-cost pathway, at 974 EUR per tonne of ethylene. When assuming CDR credits valued at the EU Emission Trade System (ETS) carbon price, both MTO and bio-naphtha routes are unable to fully offset their higher feedstock and conversion costs by 2030, leaving them less competitive than fossil-based or CCS-integrated alternatives. Between 2030 and 2050, under carbon dioxide (CO₂) shadow prices of up to 480 EUR per tonne of CO₂, several low-carbon pathways, including bio-naphtha, pyrolysis oil blends, and using local and imported bio-methanol, can become cost-competitive with fossil naphtha cracking (985 EUR per tonne of ethylene), assuming that storing “negative” captured CO₂ can be monetised as a revenue stream. However, if only Europe applies carbon pricing, its products will not be competitive. At the same time, the European Union will have to protect its own market against cheap fossil imports to create a level playing field on its own market, making comparable carbon pricing within different regions a decisive factor for the competitiveness of the transformation. Ethane cracking with CCS reaches cost parity with fossil pathways at around 70 EUR per tonne of CO₂, while blended bio-naphtha, pyrolysis oil, and other CCS-integrated routes reach cost parity with fossil pathways at EU ETS price levels of 220 to 340 EUR per tonne of CO₂. Biogenic MTO requires an ETS price of approximately 340 EUR per tonne of CO₂ to achieve cost parity.

Security of energy and feedstock supply is crucial for chemical production. It can only be achieved through resilient and well-maintained infrastructure and timely development to facilitate transformation.

The chemical industry in the TCR has developed in tandem with the region’s industrialisation, benefitting from a dense network of waterways, railways, and pipelines that link major demand centers like the Rhine-Ruhr area with key ports such as Antwerp (BE), Rotterdam (NL), and Duisburg (DE). Over time,



robust energy and feedstock supply chains have emerged, supporting a deeply interconnected cross-border chemical cluster.

Many chemical processes run continuously throughout the year without interruption and therefore require a steady and reliable supply of energy and raw materials. If this security of supply breaks down or other disturbances occur, this can come at massive costs for the companies and even lead to regional shortages of chemical products that will affect end consumers. All infrastructures like roads, waterways, pipelines and electrical grids are critical to the chemical industry but some are reaching their capacity limits or are becoming increasingly unreliable. For a successful transformation towards climate neutrality, the following aspects need to be considered:

- Strategic electric infrastructure needs to be upgraded to enable electrification pathways.
- For hydrogen (H₂) networks, techno-economic optimised model results show that the risk of underutilisation of H₂ cross-border transport capacity is substantial. Using similar modeling techniques, cost effective alternative pathways appear (e. g. carbon capture) which do not require cross-border H₂ transport.
- Timely deployment of a cross-sectoral cross-border CO₂ network infrastructure is crucial to enable swift emission reductions in several industrial sectors. On a longer time horizon, biobased processes can connect to the network and generate negative emissions.
- Recognising bio-CCS in the EU ETS as carbon dioxide removal significantly increases capture volumes and biomass use but also comes with potential implications for sustainable biomass cycles and investments in CO₂ transport and storage capacities.
- Cross-border alignment and coordination on energy and molecule infrastructure planning is key for the TCR. More studies and discussions with companies and relevant stakeholders are needed to correctly determine routing and dimensioning of the network and to identify the least cost solutions.

Transition needs ongoing competitiveness. The chemical industry is as diverse as its products - there is no "one size fits all solution".

High production volumes require large amounts of energy and feedstock. With more costly renewable feedstock and projected energy prices remaining at high levels, the successful transformation needs policy support. Under today's conditions, regulations and emission constraints, EU producers struggle to remain globally competitive. This is expected to worsen in the future. Regulations and policies need to be adapted to ensure the survival of the chemical industry in Europe. Competitiveness and the transition of chemical industry need to go hand in hand. For example, electricity prices are generally lower in China and the US in comparison to Europe. Lower electricity prices lead to more cost effective pathways for electrification, which is especially essential to defossilise downstream chemical production processes. For upstream production processes, including steam cracking, pathways leveraging on feedstock changes and CCS are key.

Downstream products that are closer to consumer markets also show higher potentials for electrification of their production routes. In addition, end consumers often tend to exhibit a certain "willingness to pay" for higher prices depending on the market segment and price sensitivity, if a product has a lower carbon footprint. This potential to pass higher costs on in combination with a tendency for higher margins at the end of the value chain results in a smaller financial risk or burden for these downstream producers when transforming their processes. However, to produce green products, these downstream producers depend on green feedstock from upstream producers. In other words, there is no downstream transformation without upstream transformation.

The current policy package needs to be revised and adapted to guarantee the continuation and transformation of chemical activities in Europe.



The lack of competitiveness is one of the main hurdles the chemical industry in the EU is currently facing, both for operations continuation, due to structural cost disadvantage of EU versus other regions, as well as for investing in the transition, due to cost disadvantages of sustainable compared with fossil technologies. While EU policies, through imposing climate and regulation costs, have a significant contribution to these cost disadvantages, the current legislation does not offer companies an adequate framework to solve their competitiveness issues. One of the cornerstones of the current policy framework aimed at levelling out competitiveness disadvantages is the carbon border adjustment mechanism (CBAM). In this report, several shortcomings of the CBAM are identified. In its current form, CBAM cannot guarantee a level playing field between European producers and other global regions, meaning that it will not protect industry from climate (EU ETS)-related competitiveness challenges and consequent carbon leakage. Other EU policy initiatives, such as the Net Zero Industry Act, the Industrial Accelerator Act or the upcoming Circular Economy Act, are also aimed at improving industrial competitiveness. However, the challenge of preventing further loss of local production and increasing imports of downstream products, is not yet fully addressed. The Critical Chemical Alliance (CCA) is a current exercise identifying chemical productions as 'critical' to remain on European soil, in order to selectively safeguard them. This initiative offers the chance to locally retain essential parts of chemical value chains. At the same time however, it bears the risk of shifting the focus of policy makers away from developing solutions to the structural problems affecting the whole industry towards only solving the issues of a set of selected cases. It is vital to the success of this exercise to keep the complexity of the chemical sector in mind, where processes are very diverse and highly interconnected. The outcome might result in the risk of further capacity reductions and closures of such processes not being classified 'critical', with potential unforeseen effects on the whole value chain.

Throughout the stakeholder exchange in this study, several options to complement the current policy package were discussed: different measures to lower electricity prices, a reform of ETS (e. g. with a reintroduction of grandfathering emission certificates), and dedicated market pull mechanisms such as a system of green premiums where consumers (or public authorities) pay a premium for the recycled or green content in products. Broadening the scope of 'green' H₂ and H₂-based molecules to 'low-carbon', or providing a clear regulatory framework for carbon management including mechanisms for negative emission revenues from biogenic CO₂ capture and storage, were also discussed. These options are examples from the discussion with the companies to encourage specific policies aiding the survival of chemical production in the TCR.



TABLE OF CONTENTS

IMPRINT.....	2
ACKNOWLEDGEMENTS.....	3
EXECUTIVE SUMMARY	I
TABLE OF CONTENTS	I
LIST OF FIGURES	I
LIST OF TABLES	I
LIST OF ACRONYMS	I
LIST OF UNITS AND SYMBOLS.....	I
SUMMARY OF KEY OBSERVATIONS, MESSAGES AND INSIGHTS.....	1
1 Introduction	1
1.1 Trends in the chemical sector	1
1.2 Scope & Objectives of this study.....	2
2 Current status of the Trilateral Chemical Region	4
2.1 Production of chemicals	4
2.1.1 Analysed chemical value chains – Focus: steam cracker value chain.....	6
2.1.2 Current feedstocks.....	9
2.1.3 Production data: 2019-2024 trends	11
2.2 Trade flows between regions	15
2.2.1 Trade balances: current state and 2019-2024 trends.....	15
2.2.2 Influence of recent political developments.....	19
2.2.3 Main trade partners.....	21
2.3 Competitiveness of current value chains	26
2.3.1 Evolving industrial landscape in the TCR: plant closures and new projects	28
2.4 Stakeholder perspectives on the current state of the TCR	31
3 Future Perspectives.....	37
3.1 Novel pathways to producing key chemicals	37
3.1.1 Biomass based pathways to produce olefins and aromatics.....	38
3.1.2 Plastic waste based pathways to produce olefins and aromatics	39
3.2 Scenarios investigated in this study	42
3.3 Ethylene production cost analysis 2030-2050	44
3.4 Infrastructure analysis for H ₂ and CO ₂ pipelines.....	51
3.4.1 Hydrogen infrastructure	52
3.4.2 Infrastructure implications for CO ₂ networks	59
3.5 Feedstock and energy costs on global scale under structural policy uncertainty.....	68
3.5.1 Parameters and assumptions	68
3.5.2 Competitiveness comparison in a global policy context	70



3.6 Overview of EU policies impacting chemical value chains	74
REFERENCES	1
Annex A. Current status and methodology	1
Annex B. 3C-VaCS Modelling Tools	1
Annex C. H₂ infrastructure model	1
Annex D. CO₂ infrastructure model	1
Annex E. Biomass based pathways for the production of olefins & aromatics	1
Annex F. Biomass availability in the TCR	1
Annex G. Plastic waste based pathways for the production of olefins and aromatics	1
Annex H. Plastic waste availability in the TCR	1
Annex I. Future Perspective of Industry Stakeholders	1

LIST OF FIGURES

Figure 1. Integrated chemical production in the Antwerp petrochemical cluster, including the INEOS ethane cracker and Borealis propylene dehydrogenation units. Own representation with data from [12], [13].	5
Figure 2. Upstream vs. downstream parts of chemical value chains: schematic representation.	6
Figure 3. Steam cracker value chain: a part investigated in the project. The segments selected for production and trade data analysis are highlighted.	7
Figure 4. Schematic map of the crude oil pipelines in the TCR.	9
Figure 5. Global supply for embedded carbon in chemicals and derived materials by type of feedstock, reference years: 2015-2022. Own illustration based on data from [24].	10
Figure 6. Total production volumes of selected commodities in the TCR from 2019 to 2024 reported in open statistical data from Eurostat and Landesdatenbank NRW [26], [27]. Missing data for a specific region or year does not indicate an absence of production of the commodity, but that the corresponding statistical data is not publicly available.	11
Figure 7. Estimated capacity utilisation of all steam crackers located in the TCR and Germany. The analysis for the Netherlands and Germany was based on total production data from Eurostat [26]. For Belgium and NRW, the estimation is based on emission data [28], [29] using an emission factor of 1.73 tCO ₂ /t ethylene [30] and information from company interviews, as the production data for these regions was limited or identified as unreliable according to stakeholder feedback. Only years with available data are shown.	12
Figure 8. European production of ethylene, propylene and benzene from 1999 to 2024 and average annual crude oil prices over the time period. Source of crude oil prices [34]. Production numbers from [18].	14
Figure 9. Car production and ethylene and propylene production from 1999 to 2024 in Europe. Source of car production [35], ethylene/propylene production numbers from [18].	14
Figure 10. Exports, imports and regional trade volumes for olefins, polymers and other bulk chemicals (methanol and ammonia) for the BE-NL-NRW region in 2024, based on data from [27] and [39]. The BE-NL-NRW trade was estimated as the a sum of the volumes traded between Belgium, the Netherlands, and North Rhine-Westphalia. Does not include the trade flows between North Rhine-Westphalia and Germany, as the data is not available in the statistics.	16
Figure 11. Comparison of the trade (export and import) and production data in Belgium, the Netherlands and NRW in 2024. Based on [26], [27], [39]. Does not include the trade flows between North Rhine-Westphalia and Germany, as the data is not available in the statistics.	18
Figure 12. Trends in trade balances for analysed commodities in 2019-2024. Positive values indicate net-exports of a commodity while negative values indicate an import surplus. Based on the data from [45]. Does not include the flows between North Rhine-Westphalia and Germany, as the data is not available in the statistics.	20
Figure 13. Ten main import and export partners of the Netherlands in 2024 for the analysed commodities. Based on the data from [45]. See Annex A for Belgium (Figure 47, Annex A, p. 5), North Rhine-Westphalia (Figure 48, Annex A, p. 6) and methodology. Does not include the flows between North Rhine-Westphalia and Germany, as the data is not available in the statistics.	23
Figure 14. Net trade balances for C4 products in BE-NL-NRW in 2024, and for benzene and p-xylene in the Netherlands in 2024. The analysis does not include the flows between North Rhine-Westphalia and Germany, as the data is not available in the statistics.	24
Figure 15. Net trade data analysis: distribution of the net exports and imports over different trade partner groups for methanol (above) and ammonia (below). Based on the data from [45]. The analysis does not include the flows between North Rhine-Westphalia and Germany, as the data is not available in the statistics.	25



Figure 16: Value distribution of steam cracking products, based on average export prices from Belgium in 2024. Inner circle represents the weight distribution of the products while the outer circle depicts the corresponding value in USD/t.....	27
Figure 17. Plant closures in the TCR: ceased production in 2022-2025 and announced closures for 2026-2027. The size of the circles does not correlate with the nameplate capacity. State: January 2026, non-exhaustive list.....	29
Figure 18. New commercial scale facilities (2022-2025) and those announced for commissioning in 2026-2028. Only projects with a nameplate capacity above 10 kt/a were considered. The size of the circles does not correlate with the nameplate capacity. State: January 2026, non-exhaustive list.....	31
Figure 19. Stakeholder voting for the most important strengths of the TCR.....	32
Figure 20. Stakeholder voting for the most important weaknesses of the TCR.....	33
Figure 21. Stakeholder voting for the most important opportunities for the TCR.....	34
Figure 22. Stakeholder voting for the most important opportunities for the TCR.....	35
Figure 23. Plastics waste flow in the Netherlands in 2022. Own representation with data from [93], [94]..	40
Figure 24. Plastic waste availability in Germany in 2023-2024. Own representation with data from [98]..	41
Figure 25. Plastic waste availability in Belgium in 2022-2023. Own representation with data from [99], [100].	41
Figure 26. Ethylene production routes and cost in TCR by 2030. Own modelling work, based on [102].	48
Figure 27. Ethylene production routes and cost in TCR by 2050. Own modelling work, based on [102].	49
Figure 28. Bio-naphtha price evaluation of ethylene production cost in 2050. Own model results based on [102] and Table 12.....	51
Figure 29. Inputs to the H ₂ infrastructure model.....	53
Figure 30. An overview of the inputs and outputs of the H ₂ infrastructure optimisation model. Own work.	54
Figure 31. System boundary for green H ₂ infrastructure analysis in this study across both central and decentral H ₂ production scenarios. Own work.....	55
Figure 32. Optimal H ₂ infrastructure layout in 2050 in the TCR across defined demand and supply scenarios under optimistic calculation of Levelised Cost of H ₂ (LCOH). Own work.....	56
Figure 33. H ₂ infrastructure under realistic calculation of LCOH across the TCR in 2050. Own work.....	58
Figure 34. Modelled TCR region, six industry sectors, candidate pipelines, storage locations and terminal points. Own work.....	60
Figure 35. CCTS model inputs and outputs, including a data processing step. Own work.....	61
Figure 36. Annualised CO ₂ pipeline construction and maintenance costs. Materials: cost of pipe, coating, and cathodic protection. Labour: construction labour. ROW: cost for the right-of-way permit in relation to building the pipe and potential damages to landowners' property during construction. Miscellaneous: costs of engineering, supervision, contingencies, telecommunications equipment, freight, taxes, allowances for funds used during construction, administration and overheads, and regulatory filing fees. Data on cost fractions obtained from [111].....	62
Figure 37. Sankey diagram of the chemical sector incl. organics (PEA), polymers (PE) and olefines. The columns indicate the 5 baseline scenarios. Figure a) depicts the 2030 results with CDR credits, figure b) without CDR credits. Note that the thickness of the flow indicates the amount of production sites and not their capture volume.....	64
Figure 38. Sankey diagram of the chemical sector incl. organics (PEA), polymers (PE) and olefines. The columns indicate the five baseline scenarios. Figure a) depicts the 2050 results with CDR credits, Figure b) without CDR credits. In Figure a) olefines will be produced nearly entirely via mixed bio-routes with MEA capturing which get rewarded with CDR credits. Note that the thickness of the flow indicates the amount of production sites and not their capture volume.....	64
Figure 39. Comparison of pipeline and storage investments for 2030 (figure a) and 2050 (figure b), both for realistic H ₂ prices and with CDR credits.....	65

Figure 40. Difference in pipeline routing between the 2030 global effort scenario with and without CDR credits. The scale at the right of each figure depicts the pipeline size.	66
Figure 41. The energy and feedstock cost component of olefin production as a function of CO ₂ costs in EU, China and USA.	70
Figure 42. Energy and feedstock components to produce Urea under various CO ₂ prices. As a comparison, the green H ₂ route to produce ammonia and urea is included as well for 2030 and 2050. ...	72
Figure 43. Costs for urea production for a producer active only in EU (left) and a producer active in China exporting 30 % to the EU market (right). The X-axis represents the percentage of products produced using green H ₂	73
Figure 44. Ammonia value chain.	1
Figure 45. Total production volumes of selected commodities in the TCR from 2019 to 2024. Based on available statistical data from [26], [27].	3
Figure 46. Net trade flows analysis: flows between the TCR countries and the rest of the world as of 2019 (above) and 2024 (below). Trade flows include ammonia, the steam cracker products ethylene, propylene, butene and butadiene, the polymers polyethylene and polypropylene. Only net trade flows above 50 kt are displayed. The colour of an arrow gets more intense towards its destination to indicate the direction of the respective flow. Trade flow of NRW-DE is not included due to the limited publicly available data.	4
Figure 47. Ten main import and export partners of Belgium in 2024 for the analysed commodities. Based on the data from [33].	5
Figure 48. Ten main import and export partners of North Rhine-Westphalia in 2024 for the analysed commodities. Based on the data from [33]. Trade flows from and to the rest of Germany are not available in international trade statistics and not shown here but expected to be significant.	6
Figure 49. Distribution of the interviewed companies along the steam cracker value chain.	7
Figure 50. Handout for the SWOT strategy development.	8
Figure 51. Overview of the main steps of the GIS analysis used to derive the simplified candidate hydrogen network topology in the Trilateral Industrial Region. The workflow includes the identification of candidate new and repurposed pipelines, industrial demand nodes and underground hydrogen storage sites.	12
Figure 52. Sensitivity analysis on UK storage in 2030.	3
Figure 53. Sensitivity analysis on connections between NRW with either BE or NL.	4
Figure 54. Sensitivity analysis on connections between BE and NL.	5
Figure 55. Simplified block flow diagram of biomass to methanol process [82].	2
Figure 56. Block flow diagram of lignocellulosic ethanol process [167].	7
Figure 57. Process flow diagram of biomass pyrolysis with hydrotreating process [169].	9
Figure 58. Block flow diagram of biomass based Fischer-Tropsch process [171].	10
Figure 59. Anderson-Schulz Flory distribution for the FT process.	11
Figure 60. Ways of recycling plastic waste (adapted from CE Delft report [187]).	1
Figure 61. Block flow diagram of plastic to olefins via pyrolysis process [189].	3
Figure 62. Block flow diagram of plastic to olefin via methanol process [189].	7
Figure 63. Process flow diagram of naphtha catalytic reformer process [191].	9
Figure 64. Block flow diagram of plastic waste to aromatics via methanol process [189].	11
Figure 65. Plastic flow in the Netherlands as per Plastics Europe data for 2022 [99].	3
Figure 66. Plastic flow in Germany as per Plastics Europe data for 2022 [99].	5
Figure 67. Plastic flow in Belgium as per Plastics Europe data for 2022 [99].	6
Figure 68. Most important actions, extracted from the developed strategies and assigned to the responsible stakeholder groups.	3

LIST OF TABLES

Table 1. List of steam crackers with their nameplate capacities operating in the TCR. State: January 2026.	7
Table 2. Olefins productions results per scenario with CDR on. Upper values=2030, lower values=2050.	46
Table 3. Parameter assumptions cross-border comparison.	69
Table 4. Steam cracker production capacities in Europe in the end of 2024 and January 2026.	2
Table 5. Share of the TCR’s production volumes of selected commodities in the overall production of the EU27. Based on [26], [27].	2
Table 6. Total production of selected commodities in Germany and NRW. Based on [26], [27].	3
Table 7. Export-to-domestic consumption ratio for the analysed commodities in the TCR.	3
Table 8. Confrontation matrix for evaluating the correlation of internal and external factors.	8
Table 9. Overview of olefins production routes per 3C-VaCS scenario.....	1
Table 10. Description of olefin production routes used in the 3C-VaCS scenarios.	4
Table 11. Cost and CO ₂ related parameters for olefin production routes used in the 3C-VaCS scenarios in 2050.....	4
Table 12. Overview of bio-naphtha production costs for 2030 and 2050.	7
Table 13. Overview of imported bio-naphtha production costs for 2030 and 2050.....	7
Table 14. Overview of local bio-methanol production cost (EUR/t) for 2030 and 2050.	8
Table 15. Overview of imported bio-methanol production cost (EUR/t) for 2030 and 2050.....	8
Table 16. Calculation of the local bio-naphtha potential based on the biomass availability in Belgium, the Netherlands and Germany.....	8
Table 17. Calculation of the local bio-methanol potential based on the biomass availability in Belgium, the Netherlands and Germany.....	8
Table 18. Main input assumptions, pathways to produce ethylene.	9
Table 19. Current and future electricity prices in the TCR.....	10
Table 20. Assumptions on the costs and performance parameters of renewable electricity generation and H ₂ production technologies [145], [148], [154], [155], [156], [157], [158].....	1
Table 21. Levelised cost of H ₂ for different configurations of electrolysis units placed in the energy system of TCR.	1
Table 22. Assumptions on the costs and performance parameters of storage technologies in 2050 [161], [162].....	3
Table 23. Costs of candidate pipes and compressors [163].....	3
Table 24. Values of LCOH from the stylized optimization model across different green H ₂ production pathways [163].....	3
Table 25. Main numeric CCTS optimisation results for the year 2030.	2
Table 26. Main numeric CCTS optimisation results for the year 2050.	2
Table 27. Collection of quantitative results of all sensitivity analyses. Differences in cost are calculated based on the infrastructure components only (using the relative cost difference) and not based on the total system costs incl. industry production costs (using the absolute cost difference compared to the base scenario).	3
Table 28. Pathways to produce base chemicals included in this study.	1
Table 29. Mass and energy flows of methanol production via biomass gasification [82].....	3
Table 30. Mass and energy flows of methanol production via biogas [165].	4
Table 31. Mass, energy and economic characteristics of methanol to olefin process [166].	5
Table 32. Mass, energy and economic characteristics of methanol to aromatics process [160].	6
Table 33. Mass flows and CAPEX for the production of lignocellulosic ethanol [167].....	7
Table 34. Mass flows and CAPEX for the ethanol to ethylene dehydration process [168].	8
Table 35. Fast pyrolysis yields from corn stover feedstock [169].	9
Table 36. Mass and energy flows of pyrolysis and upgrading for bio naphtha production. Adapted from Wright et al. [169].	10

Table 37. Mass, energy and economic characteristics of Fischer Tropsch process. Adapted from Tan et al [171]..... 12

Table 38. Biomass classification for the evaluation of bio-based chemical value chains [82]. 2

Table 39. Main assumptions of the three scenarios in the Concawe report [89]. 3

Table 40. Main assumptions for biomass allocation for bioenergy [88]. 4

Table 41. Estimated biomass availability in the Netherlands by 2030 based on [88]. 5

Table 42. Estimated biomass availability in Germany by 2030 based on [88]. 6

Table 43. Estimated biomass availability in Belgium by 2030 based on [88]. 7

Table 44: Example of plastic waste recycling technologies, their input and output. 2

Table 45: Mass, energy and economic characteristics of plastic pyrolysis process [166]. 4

Table 46: Yield comparison of naphtha, diesel and vacuum gas oil steam cracking processes (typical example) [190]. 5

Table 47: Mass, energy and economic characteristics of naphtha steam cracking process [166]. 6

Table 48: Mass, energy and economic characteristics of plastic waste gasification followed by syngas to methanol process [166]. 7

Table 49: Mass, energy and economic characteristics of methanol to olefin process [166]. 8

Table 50: Mass, energy and economic characteristics of naphtha catalytic reforming process [191]. 9

Table 51: Mass and economic characteristics of fluidised catalytic cracker to produce naphtha from heavy oils [192]. 10

Table 52: Mass, energy and economic characteristics of methanol to aromatics process [166]. 11

Table 53. Examples of thermoplastics and thermosets. 1



LIST OF ACRONYMS

1G	First-generation
2G	Second-generation
approx.	approximately
ARRRA	Antwerp-Rotterdam-Rhine-Ruhr-Area
ATR	Autothermal Reformer
BE	Belgium
bio-CCS	Biogenic Carbon Capture and Storage
BM	biomass
BTX	benzene, toluene, xylene
C10	Products of steam cracker with 10 carbon atoms
C4	Products of steam cracker with 4 carbon atoms (butene and butadiene)
C5	Products of steam cracker with 5 carbon atoms
C7	Products of steam cracker with 7 carbon atoms
C9	Products of steam cracker with 9 carbon atoms
CAPEX	Capital Expenditure
CBAM	Carbon Border Adjustment Mechanism
CC	Carbon Capture
CCS	Carbon Capture and Storage
CCTS	Carbon capture, transport & storage
CDR	Carbon Dioxide Removal
cf.	confer
CH ₄	Methane
CNOs	Carbon network operators
CO	Carbon monoxide
CO ₂	Carbon dioxide
DACCS	Direct air carbon capture and storage
DBSCAN	Density-Based Spatial Clustering of Applications with Noise
DE	Germany
DKR 324	Polyethylene
DKR 329	Polypropylene
DKR 350	Mixed plastic waste
e. g.	Exempli gratia, for example



EDCR	Export-to-domestic consumption ratio
engl.	englisch
EPS	Expanded polystyrene
etc.	et cetera, and the others
ETS	Emissions Trading System
EU	European Union
EUR/MW	Euro per Megawatt (unit of power)
EUR/MWh	Euro per Megawatt hour (unit of energy)
EU27	The member states of EU27
EU27+3	The member states of EU27 including Switzerland, the United Kingdom and Norway
FCC	Fluid catalytic cracking
FT	Fischer-Tropsch
GHG	Green House Gas (CO ₂ , CH ₄ , NO _x , ...)
H ₂	Hydrogen
HDPE	High Density Polyethylene
HTL	Hydrothermal liquefaction
HVC	High Value Chemicals
i. e.	id est, that is, in other words
ILUC	Indirect land use change
incl.	including
IRA	Inflation Reduction Act
LCOH	Levelised Cost of Hydrogen
LDPE	Low Density Polyethylene
LH2	Liquefied Hydrogen
LHV	Lower Heating Value
LLDPE	Linear Low-Density Polyethylene
LPG	Liquid Petrol Gas
MEUR	Million Euro
Mio.	Million
MoGas	Motor Gasoline
MSW	Municipal solid waste
MTBE	Methyl Tertiary-Butyl Ether
MTO	Methanol-to-olefins



n.a.	Not available
NG	Natural gas
NL	The Netherlands
NRW	North Rhine-Westphalia
NWE	Northwest Europe
OPEX	Operating Expenses
PDH	Propane dehydrogenation
PET	Polyethylene terephthalate
PIONA	n-paraffins, iso-paraffins, olefins, naphthene, and aromatics
PP	Polypropylene
PPA	Power Purchase Agreement
PS	Polystyrene
PV	Photovoltaic
PVC	Polyvinyl chloride
pygas	Pyrolysis gasoline
pyoil	Pyrolysis oil
Q2	Second quarter of the year (April-June)
R&I	Research and innovation
REDII	Renewable Energy Directive II
REDIII	Renewable Energy Directive III
r-WGS	Reversed water gas shift
s	Site wise
S	Strength
sine qua non	an indispensable requirement, an essential condition
SMR	Steam Methane Reforming
SNG	Synthetic natural gas
SOC	State of Charge
SWOT	Strengths, Weaknesses, Opportunities, Threats
syngas	Synthesis gas (mixture of H ₂ and CO)
T	Threat
T&S	transport and storage
TCR	Trilateral Chemical Region
TRL	Technology Readiness Level
TYNDP2024	Ten-Year Network Development Plan of 2024

UK	United Kingdom
US/USA	United States of America
USD	US-Dollar
v	Volume wise
VCI NRW	Verband der chemischen Industrie Nordrhein-Westfalen
VNCI	The Royal Association of the Dutch Chemical Industry
vs.	versus
W	Weakness

LIST OF UNITS AND SYMBOLS

a	year
bar	pressure
°C	Degrees Celsius
EUR	Euro
GW	Gigawatt
kg	Kilogram
km	Kilometer
kt	kilotons
kWh	kilowatt hour
m ³	Cubic meter
MDT	Million dry tons
MtCO ₂	Million tons CO ₂
Mtoe	Million tonnes of oil equivalent
MW _e	Megawatt electric
MWh	Megawatt hour
Nm ³	Normal cubic meter
t	ton
tBN	ton bio naphtha
TJ	Terrajoule
TWh	Terrawatt hour
wt%	weight percent
PJ	Peta joule
vol%	volume percent



SUMMARY OF KEY OBSERVATIONS, MESSAGES AND INSIGHTS

Chapter 1.1 Trends in the chemical sector

Main observations

- EU27's share of global chemical sales has declined significantly over the past 20 years: from 27 % in 2004 to just 13 % in 2024.
- Increasing dominance of Asia in the global chemical market is observed
- China's trade balance shows a substantial surplus (by value) in fine and specialty chemicals.
 - China was the largest source of chemical imports for the EU27 with 46 % in 2024.
 - Fear of the flooding of cheap imports and of unfair competition for European chemical industry is growing.
- Global market shifts (e. g. US tariffs), global overcapacity, high energy and production costs, ongoing industry crisis, overregulation, strategic portfolio reviews as well as the need for transformation to achieve the climate goals are further affecting the European chemical industry.

Chapter 2.1 Production of chemicals

Key Insights

- About 1,300 chemical companies of various sizes are located in the TCR. The chemical industry provides in total about 200,000 direct jobs for the region.
- The companies in the region are often located in chemical parks (Verbund sites) resulting in a high degree of integration.
- The TCR is an important hub of European polymer production, concentrating a large proportion (approx. 42 % in January 2026) of steam cracker capacity.
- In 2024, the TCR produced 42 % of HDPE and 41 % of polypropylene produced in the EU27.

Chapter 2.1.1 Analysed chemical value chains – Focus: steam cracker value chain

Key Insights

- The highest GHG emissions, energy consumption, and production volumes occur in the upstream segment, whereas value creation primarily takes place in the downstream part of the value chain.
- The differences between upstream and downstream processes also lead to different requirements on the path to climate neutrality.
- If upstream production is disrupted by plant closures, the risks for downstream operations also increase, and vice versa.
- The challenges for the transition were observed to be similar in other chemical value chains (ammonia, chlorine).

Chapter 2.1.3 Production data: 2019-2024 trends

Key Insights

- Since 2019, steam crackers in the TCR were operated below the aspired 95 % capacity utilisation, resulting in declining olefin (ethylene, propylene) production in the region. This trend mirrors the European trend, where the average steam cracker operation rates dropped from 83 % in 2019 to 71 % in 2024.
- The sharpest decrease in the steam cracker utilisation rates followed Russia's war on Ukraine and has not recovered since.
- The production of the main steam cracker products, ethylene and propylene, in Europe is demand-driven and therefore relies on the downstream sector (e. g. packaging and the automotive industry).



Chapter 2.2.1 Trade balances: current state and 2019-2024 trends

Key Insights

- Depending on the commodity group, the TCR had different trade balances in 2024:
 - Net importer of olefins, with country-specific variations: Belgium – heavy importer of ethylene and propylene, the Netherlands – significant net exporter of olefins.
 - Overall, the TCR is a net exporter of polymers.
 - The region was a net importer of ammonia and methanol: while ammonia is imported primarily for domestic consumption, over 60 % of methanol is re-exported in Belgium and the Netherlands, positioning the major ports in the TCR as a transit hub.
- Since 2019, overall decrease of trade flows, both imports and exports, is observed. A general decline in polymer net exports, particularly in NRW, is seen, which can be attributed to lower local demand, as well as weaker demand in the rest of Germany.
- While there are no significant net imports of polymers in primary form from China to the TCR, large volumes of finished consumer goods are entering the European market. This can result in a decrease in local polymer demand and impact upstream and downstream industries negatively.

Chapter 2.2.2 Main trade partners

Key Insights

- For the analysed commodities, the intensity of two-way trade is particularly strong at the TCR level. This highlights the vital role of a highly integrated infrastructure network within the region to enable this trade.
- Steam cracker products are commonly traded on regional markets.
 - Some products, such as benzene and C4, are also attractive for non-European countries.
 - Reduction of the steam cracker capacities would probably not lead to higher imports of ethylene/propylene but lead to increased imports of the downstream products.
- Over 70 % of exports of analysed polymers were for the European market. This underscores both the significance of the domestic European market for the TCR, as well as the importance of the TCR-based polymer producers for the customers across Europe.
- Ammonia and methanol, the other key bulk chemicals, are currently largely imported into the TCR from non-European suppliers. The reliance on only few critical trade partners combined with an unstable geopolitical environment, highlights the need to maintain strategic production capacities, develop diversification strategies, and ensure infrastructure that enables a rapid shift to alternative suppliers within the TCR.
 - In 2024, just two countries accounted for about 71 % of total imports of methanol into the BE-NL-NRW region: the USA (37 %) and Trinidad and Tobago (34 %). For ammonia, three countries supplied 78 % of the region's imports: Russia (42 %), Trinidad and Tobago (23 %), and the USA (13 %).



Chapter 2.3 Competitiveness of current value chains

Key Insights

- Announced plant closures, resulting from the ongoing industry crisis and strategic portfolio reviews, have affected companies across multiple segments of the chemical value chain in the TCR, including upstream operations (refineries and steam crackers), intermediates production, polymers and specialty chemicals, as well as mechanical polymer recycling.
- For steam crackers, announced closures amount for 17 % of the total TCR's ethylene capacity. Rising global overcapacity and the commissioning of new plants operating with lighter feedstocks will put additional pressure on the TCR's conventional steam cracker operators.
 - The current production costs of European ethylene depend largely on the price of feedstock and are higher than in other parts of the world. This is one of the factors that negatively impacts the cost competitiveness of steam crackers in Europe.
- The closure of individual plants at integrated industrial sites cannot be viewed in isolation, as it increases risks for both downstream and upstream partners, as shown by recent examples in the TCR. However, it is hard to predict if a specific closure will result in a "domino effect" rippling through the value chain or if the impact is a change of supplier.
- Most large projects in the TCR that recently began operations or are nearing completion were decided before the current crisis. New, large-scale investments today appear more challenging. Some companies which are also located in the TCR invest abroad, driven by factors such as lower energy and feedstock prices or higher expected market demand.
 - The example of chemical recycling projects show that companies often begin with smaller-scale plants to test commercial viability before committing to a large-scale alternative production route.

Chapter 2.4 Stakeholder perspectives on the current state of the TCR

Key Insights

- The SWOT analysis captured the following perspectives from chemical companies in the TCR:
 - The TCR bears clear advantages for chemical production due to its location, infrastructure density and integration.
 - The higher costs compared to global competitors for energy and feedstock due to domestic policies and the dependence on imports are considered the crucial weakness.
 - Increasing resilience against dependencies on imports and external competition, through e. g. circular economy, is an important opportunity for the TCR.
 - The position on the value chain determines which factors are considered threatening (upstream: high energy and feedstock costs and limited availability of cost-competitive alternatives).



Chapter 3.1 Novel pathways to producing key chemicals

Key Insights

- Biomass-derived olefin and aromatics production proceeds via methanol, ethanol, or bio-naphtha routes, with methanol pathways requiring high energy input, generating CO₂ during syngas conditioning, and depending on high-temperature fluidised-bed reactors and capital-intensive separations.
- Alternative biomass cracker-feed routes such as pyrolysis + hydrotreating and Fischer-Tropsch synthesis yield bio-naphtha but face technical barriers including high H₂ demand, catalyst instability, and overall energy intensity; only second-generation feedstocks (per RED II) are considered in the TCR.
- European biomass availability is projected to rise from 437.5 million dry tons (MDT) in 2020 to 525-800 MDT in 2030 and 875-1,338 MDT in 2050, with the study assuming that up to 30 % of total biomass could be allocated to the chemical/materials sector.
- The import of solid biomass from outside the EU is not considered due to its high energy penalties over long distance and strict RED II sustainability requirements.
- Plastic-to-chemicals pathways include physical recycling and chemical recycling (pyrolysis, gasification, depolymerisation), with pyrolysis yielding low naphtha fractions (16 %) and thus large feedstock needs; in the 3C-VaCS scenarios, pyrolysis is included with ≤ 10 % py-oil blending in existing crackers.
- There is a large potential in the TCR collect and sort plastics to increase its reuse both for mechanical and chemical recycling. This in combination with the availability of know-how, logistics and processes as described in Chapter 2.4. However today, exact plastic waste availability figures in the TCR are constrained by data inconsistencies, high export shares and undocumented or accumulated flows.

Chapter 3.3 Ethylene production cost analysis 2030-2050

Key Insights

- Blended bio-naphtha ethylene production remains one of the most expensive pathways (2,664 EUR/t Ethylene in 2030), by 2030 driven by costly EU-imported bio-naphtha and rising biomass prices, whereas ethane cracking with CCS is the lowest-cost option (974 EUR/t Ethylene).
- Even with CDR credits valued at the EU ETS carbon price, both MTO and bio-naphtha routes cannot fully offset their higher feedstock and conversion costs by 2030, making them less competitive than fossil or CCS-integrated pathways.
- Between 2030 and 2050, under given CO₂ shadow prices (up to 480 EUR/tCO₂), several alternative routes, including bio-naphtha, py-oil blends, and imported bio-methanol, become cheaper than fossil naphtha cracking (985 EUR/t), when taking the assumption that carbon dioxide removal can be accounted for as a revenue stream.
- Carbon pricing strongly reshapes relative economics: ethane cracking with CCS reaches fossil parity at only 70 EUR/tCO₂, while blended bio-naphtha, py-oil, and other CCS pathways become competitive at an ETS price of 220-340 EUR/tCO₂; biogenic MTO requires an ETS price of 340 EUR/tCO₂ for cost parity.



Chapter 3.4 Infrastructure analysis for H₂ and CO₂ pipelines

Key Insights

- Blue H₂ and CCS-integrated retrofits remain more economical than most green H₂ supply routes, as electricity cost dominates the levelised cost of hydrogen (60-70 %). The study results for the TCR show that green H₂ is less competitive, only becoming a prominent option under conditions where CCS and biomass are restricted or unavailable. The use of hydrogen is primarily as a feedstock rather than an energy carrier.
- All scenarios feature a cross-sectoral and cross-border CO₂ network as a cost effective solution, not only on a short term but also on a long term.
- Infrastructure planning must prioritise coordinated H₂-CO₂ network development, with pipeline repurposing preferred over new-build options to limit system costs and avoid stranded assets.
- Carbon capture dominance across industries and policy scenarios highlights the need for forward-looking planning. Cross-border coordination between carbon network operators (CNOs) in the TCR should allow for timely and efficient deployment of the CO₂ value chain.
- More studies and inquiries are needed to determine the possible suppliers (and offtakers) to correctly determine the routing and the dimensioning of hydrogen and CO₂ networks, minimising the risk of underutilisation, especially of the H₂ network.
- Recognising bio-CCS in the EU ETS as carbon dioxide removal significantly increases capture volumes and biomass use but also comes with potential implications for sustainable biomass cycles and investments in CO₂ transport and storage capacities.

Chapter 3.5 Feedstock and energy costs on global scale under structural policy uncertainty

Key Insights

- Electricity prices are generally lower in China and USA, which is essential for decarbonizing downstream processes and provides a competitive disadvantage for European industries.
- Aligned with the conclusion of Chapter 3.3, green molecule production is not expected to be competitive with fossil fuels in the short-medium term in Europe .
- Even at relatively low emission costs of 70 EUR/t, emission costs present a significant increase of the cost of basic petrochemicals production. The decrease in grandfathering emission certificates will hence result in a competitive disadvantage for European companies if global products cannot be subjected to the same costs.
- The Carbon Border Adjustment Mechanism faces several challenges. One of the major challenges is the risk of increasing import of downstream products at the expense of base chemicals or semifabricates, as downstream products are mostly not covered by CBAM.
- As blue hydrogen is in the short-medium term more cost competitive than green hydrogen, implementation of REDIII regarding a share of hydrogen consumption to be green by 2030 will result in a severe competitiveness handicap for the companies subject to the requirement.
- Industrial chemical producers in China or the US have the option to send green products to the European market while supplying unabated fossil products to the home market. This flexibility is not available to European producers and may present a risk for EU producers to diversify and relocate part of their production capacity.



Chapter 3.6 Overview of policy options impacting chemical value chains

Key Insights

- The current policy package is insufficient to provide competitiveness of the chemical industry in the TCR and major preconditions for industrial transformation are missing.
- The risks of closure/relocation of chemical production and carbon leakage are not fully addressed yet. CBAM exhibits structural challenges that need to be addressed before it can effectively protect against carbon leakage. The Critical Chemical Alliance aims at establishing criteria to identify critical chemical processes and molecules. However, an approach focusing on a limited set of processes bears the risk of i. neglecting the structural challenges the whole industry is facing and ii. unforeseen effects on the value chain.
- The TCR needs to improve cross-border collaboration for correctly dimensioning and routing of molecule network infrastructure, aligning standards and permitting timelines/procedures. Further studies are needed to assess future demand on CO₂ and hydrogen transport as well as supply points connecting to the network, including the role of storage sites.
- The current policy package as well as different options to adapt or complement it were evaluated based on our study results and ii. discussed with stakeholders from the chemical industry. The following options were discussed:
 - Different measures to lower electricity prices,
 - A reform of EU ETS, e. g. with a reintroduction of grandfathering emission certificates or removing the ETS component of the electricity cost,
 - Market pull mechanisms where e. g. consumers (or public bodies) pay a premium for recycled or biogenic content in products to enable sustainable business cases
 - Different policy instruments impacting global trade, such as trade tariffs, safeguards, anti-dumping regulation, etc.
 - Broadening the scope of green hydrogen and hydrogen-based molecules to low-carbon, or providing a clear regulatory mechanism for negative emission revenues from biogenic CO₂ capture and storage.
- Innovation is a key asset of the European industry to diversify the technology options, in which the TCR can take a leading role.



1 INTRODUCTION

This report was prepared within the frame of the project **3lateral Chemical region – Value Chain Structures (3C-VaCS)**. It summarises the main results and reinforces the key messages that were derived from the conducted studies. The project is supported by the Trilateral Chemical Region Initiative [1] and was partly funded by the respective regional governments of the engaged regions Flanders, the Netherlands and North Rhine-Westphalia and Verband der Chemischen Industrie Nordrhein-Westfalen.

1.1 Trends in the chemical sector

MAIN OBSERVATIONS

- EU27's share of global chemical sales has declined significantly over the past 20 years: from 27 % in 2004 to just 13 % in 2024.
- Increasing dominance of Asia in the global chemical market is observed.
- China's trade balance shows a substantial surplus (by value) in fine and specialty chemicals.
 - China was the largest source of chemical imports for the EU27 with 46 % in 2024.
 - Fear of the flooding of cheap imports and of unfair competition for European chemical industry is growing.
- Global market shifts (e. g. US tariffs), global overcapacity, high energy and production costs, ongoing industry crisis, overregulation, strategic portfolio reviews as well as the need for transformation to achieve the climate goals are further affecting the European chemical industry.

Over the past years, the world has experienced a series of global crises. The COVID-19 pandemic, ongoing military conflicts and wars, an energy crisis, the start of a trade war with tariffs from the US, shifting political regimes, and a volatile market environment have all left their mark on global industries, and the European chemical sector is no exception. While overcapacities in chemical production have been present for decades, the latest pressure under which the industry has come has resulted in fiercer competition and in increasing amounts of plant closures in Europe while new investments are scarce [2]. Under the light of Europe's ambitious climate targets, demands for better protection against imports to ensure global competitiveness get louder. While the chemical sector in Europe is facing multiple crises and is under immense pressure right now, there are also recent developments that might improve the situation: While former allies are now closing their markets for the European chemical industry, new partnerships with India or the Mercosur agreement are being forged by the European Union [3] and new opportunities arise for the chemical industry. To prevent the loss of significant parts of the chemical industry in Europe, a "European Chemicals Industry Action Plan" has been published [4]. This plan addresses some of the major challenges faced by the industry, such as high energy prices, unfair competition and a lack of demand for green products in contrast to the EU's climate targets. In this action plan, domestic chemical production has been recognized as an important pillar of resilience and independence, and a "Critical Chemicals Alliance" is being established [5].

However, despite these strategic efforts, broader market developments paint a concerning picture. From a long-term perspective, data from Cefic [2] show that the EU27's share of global chemical sales has declined significantly over the past 20 years: from 27 % in 2004 to just 13 % in 2024¹. The US share

¹ Detailed data for 2025 has not been publicly released as of February 2026. The year 2024 is the main reference for this document but the latest publications by Cefic [6] and [2] indicate a continuation of the described downward trends.



showed a similar trend, decreasing from 22 % to 12 %. Over the same period, China's share surged from 10 % to 46 %, driven by massive capacity expansions. These shifts highlight the increasing dominance of Asia in the global chemical market. In 2024, China's overall trade balance showed a substantial surplus in fine and specialty chemicals (32.6 billion EUR), followed by petrochemicals (11.9 billion EUR) and inorganic chemicals (5.0 billion EUR). In contrast, polymers (-4.7 billion EUR), consumer chemicals (-8.5 billion EUR), and pharmaceuticals (-14.6 billion EUR) remained net import categories, as indicated by their negative trade balances [7]. In 2024, China was the largest source of chemical imports into the EU27 (33.1 billion EUR, 18 % of total imports), followed by the United States (30.0 billion EUR, 17 %).

These global market shifts are affecting the European chemical industry both directly and indirectly. A prominent example is the introduction of US tariffs: in 2024, the USA were the largest export destination for EU27 chemicals, with 40.6 billion EUR of export value (approx. 18 % of total EU27 chemical exports) [2]. This means that direct impacts of announced tariffs on future European chemical sales can be expected. Indirectly, tariffs also influence European downstream industries like car manufacturers, and thus, the domestic demand of the chemical industry. Another potential consequence is the redirection of surplus production from countries, particularly China, originally intended for the US market. This increases the fear of the flooding of the European market with cheap imports and further competitive pressure on the European industry sector.

1.2 Scope & Objectives of this study

The objective of this study was to investigate the value chains within the chemical industry of the Trilateral Chemical Region (TCR), which encompasses the Netherlands (NL), North Rhine-Westphalia (NRW, Germany), and Flanders (BE, Belgium). The focus was on the competitiveness of chemical value chains and on how it can be maintained throughout the energy transition towards a climate neutral chemical industry, changing the feedstock and energy base from fossil to alternative resources. Three research areas were examined in greater detail within the region.

Those were:

- Analysis of current value chains and mapping of chemical trade flows within the TCR.
- Examination of potential transformation pathways and policy instruments for achieving climate goals while maintaining the competitiveness of the chemical industry along the identified value chains.
- Assessment of infrastructure requirements and needs essential for transforming the regional chemical industry while maintaining competitiveness.

In addition, intensive stakeholder dialogues were held to verify the results and to ensure a realistic evaluation of the situation.



The scope of the study was set on one of the most significant value chains that supplies the chemical industry with both energy and raw materials: the steam cracker value chain. Many chemical companies, as well as other industrial sectors, rely heavily on its continuous and reliable operation. Our most important findings and insights resulting from the following tasks and analyses are described in detail in this report.

- Within this study, we mapped the current value chains and the chemical production as well as the future options for bio-based and circular raw materials.
- Based on publicly available data, we analysed trade flows between the three countries comprising the TCR and the rest of the world. Through this analysis we highlighted dependencies both within the TCR and between the TCR and the rest of the world.
- Through bilateral company interviews, we gained insights into relevant transformation challenges and opportunities for the chemical industry in the TCR, which were considered during the development of possible transformation scenarios in this study.
- A SWOT analysis, complemented by perspectives from stakeholders in the chemical industry and related sectors, was used to illustrate the characteristics of the TCR and to analyse what makes the region attractive for chemical production. It also served to analyse the risks and challenges faced by the regional chemical industry in maintaining its competitiveness.
- The costs as well as the vulnerabilities of chemical production in the TCR were investigated using the example of the steam cracker value chain.
- Future pathways were developed mapping the impact on cost of alternative production routes of steam cracker products.
- These pathways are further translated into infrastructure implications for ensuring a secure supply of H₂ and CO₂ removal of the chemical industry, as well as the cost ranges of key energy carriers.
- Relevant EU policies and their possible impact on the future of the chemical industry in the TCR were analysed.

The latest developments like plant closures, decisions on EU level or the energy prices as well as the ongoing war in the Ukraine have been considered.



2 CURRENT STATUS OF THE TRILATERAL CHEMICAL REGION

2.1 Production of chemicals

KEY INSIGHTS

- About 1,300 chemical companies of various sizes are located in the TCR. The chemical industry provides in total about 200,000 direct jobs for the region.
- The companies in the region are often located in chemical parks (Verbund sites) resulting in a high degree of integration.
- The TCR is an important hub of European polymer production, concentrating a large proportion (approx. 42 % in January 2026) of steam cracker capacity.
- In 2024, the TCR produced 42 % of HDPE and 41 % of polypropylene produced in the EU27.

The petrochemical value chain remains predominantly fossil-based and underpins the production of a vast array of goods [8]. The chemical industry forms the backbone of numerous downstream sectors, producing items such as automobiles, pharmaceuticals, and everyday consumer products. In fact, more than 95 % of all manufactured goods contain chemical components [9].

The TCR ranks among the world's top five chemical clusters and constitutes the economic backbone of the European chemical industry. The TCR is home to about 1,300 chemical companies of various sizes – ranging from global corporations to specialised medium-sized suppliers. The chemical industry provides about 200,000 direct jobs for the region [1].

Chemical production sites have evolved and expanded alongside the industrialisation of the past century and the majority are strategically located along the region's reliable supply corridors. Waterways, railway and pipeline systems connect places of high demand (such as the Rhine-Ruhr area in NRW) with harbours (Port of Antwerp-Brugges, North Sea Port, Port of Rotterdam, and an inland port in Duisburg) and producers of base chemicals. Over the past decades, solid supply chains for energy and feedstock have been established.

The three countries of the TCR act differently, but complement each other. The chemical industry of the countries can be considered as a single, interconnected chemical cluster. This is particularly evident when looking at the production of chemicals along the steam cracker value chain, which are actively traded within the region (see Chapter 2.2.2 *Main trade partners*, p. 21).

Chemical production facilities in the TCR are often located within chemical parks (so-called Verbund or integrated sites). More than 20 chemical and industrial parks², which house companies from chemical industry, are located within the TCR, including internationally operating firms that contribute significantly to cross-border value chains and global trade networks. This type of site organisation results in highly integrated production networks, characterised by short distances between producers and consumers of chemicals. In many cases, all process stages are located within a single industrial complex, either

² Flanders: Port of Antwerp, Ghent Industrial Zona and the chemical cluster by Beringen [10]; The Netherlands: Chemelot, Port of Rotterdam, Port of Amsterdam, chemical clusters by Delfzijl and Terneuzen, Chemical Cluster Emmen [10]; NRW: Chemical Park Marl, Industry Park Dorsten-Marl, CHEMPARK Krefeld-Uerdingen, CHEMPARK Dormagen, CHEMPARK Leverkusen, CHEMPARK Krefeld-Uerdingen, Chemical Park Knapsack, Chemical Park Wesseling, Chemical Park Lülldorf, Industry Park Heinsberg-Oberbruch, Industry Park Solvay-Rheinberg, Gelsenkirchen (Sholven and Horst), Bayer Chemiepark Bergkamen, Henkel Düsseldorf site, Industry Park Ruhrchemie in Oberhausen [10], [11].



under one company or shared between multiple operators. This mode of production offers a high degree of cost-optimisation through integration e. g. via simplified logistics and efficient utilisation of resources, by-products, waste streams or heat and shared services. This practice has led to highly integrated and optimised production sites, such as the Antwerp petrochemical cluster (Figure 1), where various companies located both up- and downstream of the chemical value chain produce a wide range of commodities.

At the same time, such integration poses certain vulnerabilities given the high degree of interdependence. When cost-advantages of international competitors exceed the advantages of the site integration, certain assets get under pressure with the possible consequence of plant closures. This has been happening on a to date unprecedented scale in the past 2-3 years (refer to Chapter 2.3.1 *Evolving industrial landscape in the TCR: plant closures and new projects*, p. 28). Individual closures might further increase the pressure on the other companies in the chemical cluster by putting other assets in the Verbund at risk. We found that some plant closures led to the shutdown of related production, whereas others did not disrupt downstream operations despite being directly affected. Having feedstock production nearby is certainly advantageous. However, when a part of the value chain breaks away, it is often uncertain whether subsequent production will also have to cease. Depending on the commodity, the company, and the type of goods produced, the missing part of the value chain may or may not be replaced through imports in order to maintain operations.

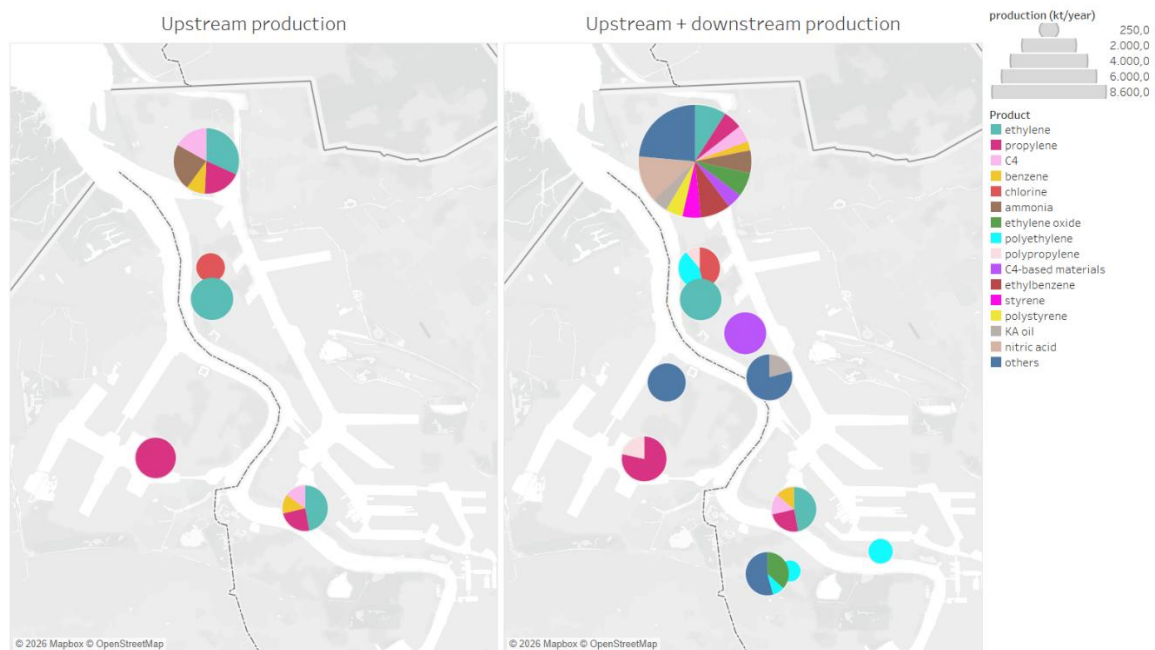

Figure 1. Integrated chemical production in the Antwerp petrochemical cluster, including the INEOS ethane cracker and Borealis propylene dehydrogenation units. Own representation with data from [12], [13].

Disclaimer: certain products and volumes are not available in the GPBV database [13] and therefore do not appear in the visualization. The visualization is intended mainly to highlight the complexity and integration of the Antwerp petrochemical cluster, focusing on the parts of the chemical value chain within the scope of this study (Figure 3).



2.1.1 Analysed chemical value chains – Focus: steam cracker value chain

KEY INSIGHTS

- The highest GHG emissions, energy consumption, and production volumes occur in the upstream segment, whereas value creation primarily takes place in the downstream part of the value chain.
- The differences between upstream and downstream processes also lead to different requirements on the path to climate neutrality.
- If upstream production is disrupted by plant closures, the risks for downstream operations also increase, and vice versa.
- The challenges for the transition were observed to be similar in other chemical value chains (ammonia, chlorine).

On the way from feedstocks to final consumer goods, such as pharmaceuticals, cosmetics, and packaging materials, the chemical industry relies on a series of complex processing steps. Companies operating at the upstream stages of chemical value chains, such as feedstock supply and base chemical production, function under different conditions compared to the companies downstream. These key distinctions are illustrated in Figure 2. The upstream segments of the value chain involve the most energy- and emission-intensive processes, making them particularly susceptible to pressures for operational transformation and sensitive to high energy costs.

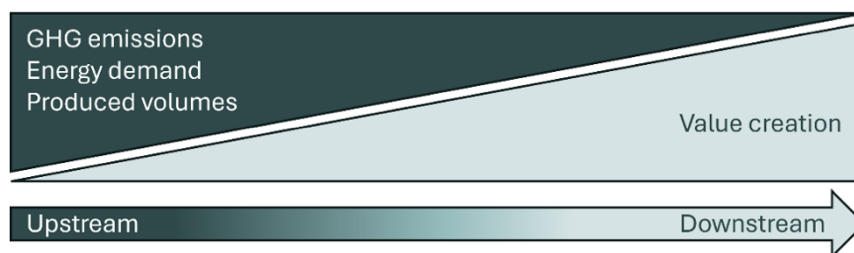

Figure 2. Upstream vs. downstream parts of chemical value chains: schematic representation.

The differences between upstream and downstream processes also lead to different requirements on the path to climate neutrality. The company interviews conducted in this project showed that upstream companies would need the infrastructure for CO₂ removal, low carbon and renewable H₂ supply to manage the large volumes of CO₂ emissions and meet their high energy and feedstock demands. For this, a pipeline infrastructure would be needed in the long-term, as well as interim solutions for the next years. The secure supply of large volumes of other alternative feedstocks such as biomass or products of plastic recycling is also needed. In contrast, the downstream companies show higher potential for electrification. This means that the corresponding expansion of grid connections is needed to meet these needs. At the same time, downstream transformation relies on the availability of affordable e. g. renewable, circular or biogenic based feedstocks supplied by upstream producers. This links the transformation processes for both segments and leads to the propagation of additional costs occurring upstream through the entire value chain. A certain “willingness to pay” among end consumers for products with a lower carbon footprint has been reported [14], [15]. This trend may offer an opportunity for the downstream sector to pass on additional costs. However, mechanisms ensuring that the upstream sector can also benefit from this development still need to be established.

An illustrative example of a chemical value chain is the **steam cracker value chain** shown schematically in Figure 3.

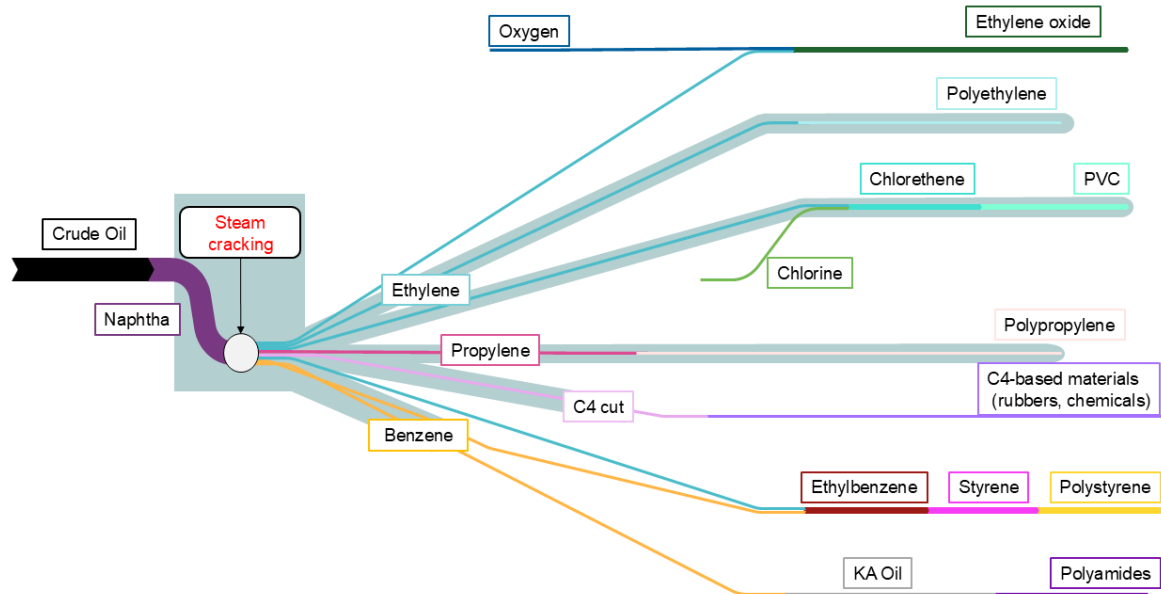

Figure 3. Steam cracker value chain: a part investigated in the project. The segments selected for production and trade data analysis are highlighted.

At the beginning of the steam cracker value chain is the distillation of crude oil in refineries, producing naphtha, which is subsequently processed in steam crackers to obtain key products such as olefins (ethylene, propylene, butene, butadiene), and aromatics (BTX: benzene, toluene, xylenes). These basic chemicals serve as feedstocks for a wide range of chemical processes, such as the synthesis of polymers and specialty chemicals, which are needed for the subsequent production of various everyday products. Numerous downstream sectors rely on steam cracker products, including plastics and polymer manufacturing, as well as the automotive, construction, paper, textile, defense, renewable sectors and agricultural industries.

Table 1. List of steam crackers with their nameplate capacities operating in the TCR. State: January 2026.

Site	Capacity, kt _{ethylene} /a	Number of crackers
BE-Antwerp-BASF	1,080	1
BE-Antwerp-TotalEnergies	1,160	2
DE-Dormagen-INEOS	1,155	2
DE-Gelsenkirchen-BP	1,073	2
DE-Wesseling-LyondellBasell	1,040	2
DE-Wesseling-Shell	310	1
NL-Geleen-Sabco Europe	760	1
NL-Moerdijk-Shell	910	1
NL-Terneuzen-Dow	1,260	2
Total, January 2026	8,748	14
Announced changes		
BE-Antwerp-INEOS (operation announced for end of 2026)	+1,450	1
BE-Antwerp-TotalEnergies (closure announced for 2027)	-550	1



The scale of steam cracker and polymer production in the TCR is remarkable (Table 1). Although the TCR covers less than 2 % of the total land area of the EU27+3 (Switzerland, the United Kingdom, and Norway), it currently (as of January 2026) accounts for approx. 42 % of Europe's total nameplate capacity of steam crackers (see Table 4, Annex A, p. 2).

In 2024, Flanders, the Netherlands and NRW together accounted for 42 % of the EU27's High Density Polyethylene (HDPE) and 41 % of its polypropylene (PP) production, while Flanders alone contributed 20 % of the EU27's Low Density Polyethylene (LDPE) output (see Table 5, Annex A, p. 2). In total, Germany, Belgium, and the Netherlands produced approx. 45 % (24.6 Mt) of plastics produced in Europe in 2024 [16].

The steam cracker operation in Flanders and NRW play particularly significant roles in the chemical industry of their respective countries. All Belgian steam crackers are located in Flanders, while NRW hosts about 63 % of Germany's total cracker capacity. Regarding polymer production in 2024, companies located in NRW accounted for 57 % of Germany's HDPE and 53 % of its polypropylene output (see Table 6, Annex A, p. 2).

While highly significant for the chemical industry in the TCR, the steam cracker value chain is also among those most severely affected by the ongoing crisis in the European chemical sector and its wave of capacity closures. According to Cefic and Roland Berger [19], the announced plant closures are primarily affecting the petrochemical segment. Steam crackers alone play here a major role: since 2019, ten steam cracker shutdowns have been announced across Europe (EU27+3), removing 5.7 Mt (or about 23 %) of ethylene nameplate capacity by 2028. The closure of three steam crackers with a total nameplate capacity of approx. 1.7 Mt ethylene has been announced in the TCR (see Chapter 2.3.1 *Evolving industrial landscape in the TCR: plant closures and new projects*, p. 28).

For a detailed analysis, such as the assessment of production and trade data, the scope was narrowed to the main steam-cracking products (ethylene, propylene, C4, and aromatics), as well as the key downstream polymers (polyethylene, polypropylene, and polyvinyl chloride (PVC)). These selected polymers account for a major share of ethylene and propylene consumption in Europe. On average, the production of polyethylene and PVC represents approx. 64 % and 12 % of total ethylene use, respectively, while around 61 % of propylene is converted into polypropylene [18].

Besides steam cracker products, **ammonia** and **methanol** are key upstream commodities produced worldwide in large volumes and used as feedstocks for a wide range of chemicals. Ammonia as a raw material serves for fertiliser production but also for cosmetics and polymers (Figure 44, Annex A, p. 1). Methanol plays an important role, for instance, for the production of resins, gasoline additives, and solvents. Considering their significance for chemical value chains and potential role as fuels and H₂ carriers, which may strongly influence global production and trade patterns, both commodities were included in the scope of our production and trade data analysis.

Steam cracking is the main source of **ethylene** production worldwide with 95 % of ethylene originating from this process [17]. **Propylene** is a product of steam cracking (69 % of propylene produced in Europe [18]) but is also produced via other routes like fluid catalytic cracking (FCC) in refineries, through propane dehydrogenation (PDH), or olefin metathesis.

Ammonia is synthesized via the Haber-Bosch process using a mixture of hydrogen and nitrogen. Traditionally, natural gas serves as the primary hydrogen source. In many cases, urea production is integrated on-site, allowing the utilization of CO₂ process emissions from the hydrogen generation in the urea synthesis process.

Methanol is traditionally produced catalytically using synthesis gas. In Europe, synthesis gas is supplied by two different methods: either through steam reforming of natural gas or by partial oxidation of oil residues in refineries. In the latter case, methanol production is integrated within the refinery.



2.1.2 Current feedstocks

The chemical industry depends on carbon-based feedstocks. Today, a large share of the chemical production is derived from fossil feedstocks such as crude oil and natural gas. Well established supply chains using pipeline systems ensure stable production of base chemicals and fuels in the largest plants of chemical industry like refineries and steam crackers. A schematic example of the crude oil pipeline network in the TCR is shown in Figure 4. The steam crackers of the TCR are connected to a cross-border pipeline system ensuring the supply with naphtha feedstock and enabling the transport of cracker products (mainly ethylene and propylene) to consumers. In a separate study the pipelines were further investigated for possible future H₂ transport options [20]. Waterways, railway systems and truck transport are additional important transport vectors for the supply of chemical industry in the region [21]. Those transport vectors, however, were not investigated in the study.

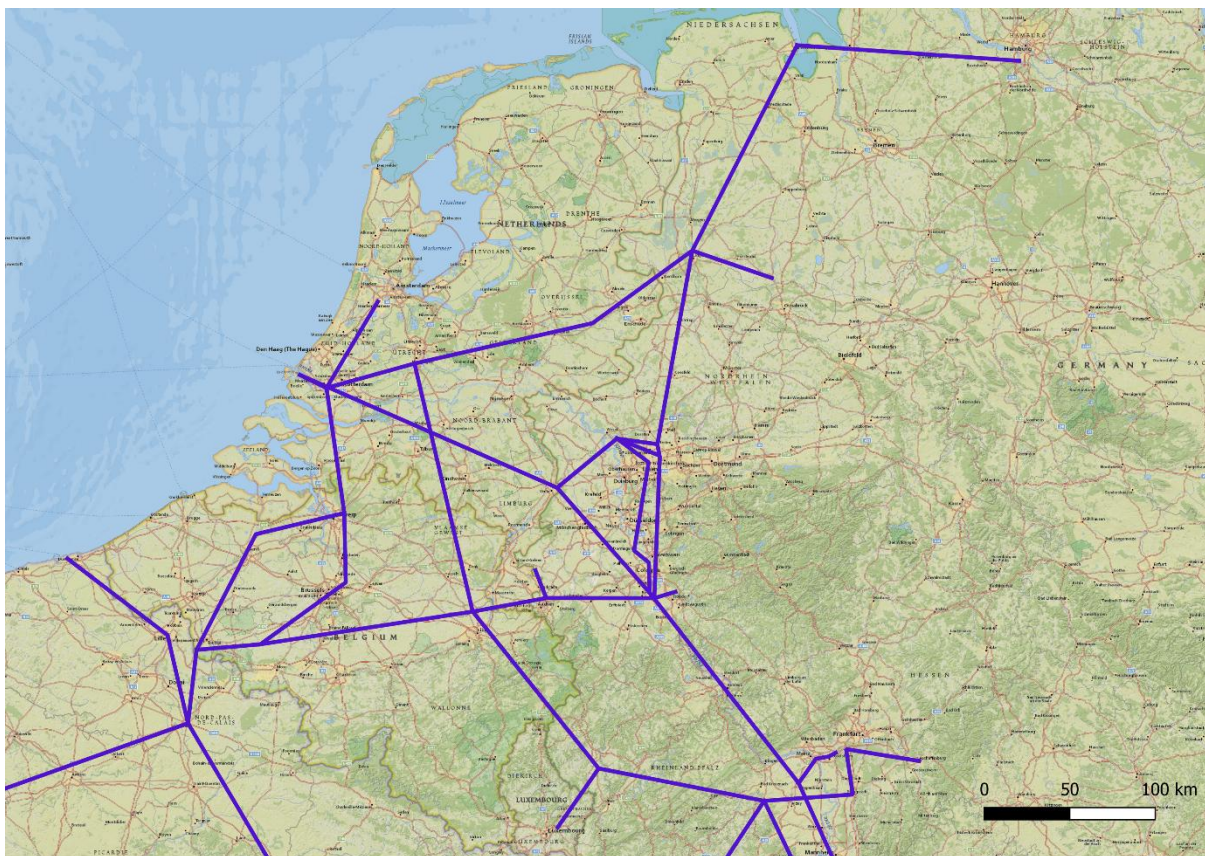

Figure 4. Schematic map of the crude oil pipelines in the TCR.

The origin of carbon embedded in chemicals and derived materials is shown in Figure 5. About 60 % of carbon in chemicals worldwide originate from crude oil, followed by natural gas with a 26 % share. Despite increasing pressure to transition towards more climate-friendly production pathways, the feedstock composition of the chemical industry in the TCR is expected to remain largely unchanged.



Naphtha is a fraction of crude oil and hence a by-product of refining. It can also be obtained via other routes, e. g. hydrocracking of pyrolysis oil (products: 40 % naphtha, 60 % diesel). Naphtha quality from crude oil distillation varies widely on the origin of the crude. Origin here refers to the basin, as one country, like Norway, can have very different crude compositions [17]. For steam cracking, naphtha with normal paraffins and little iso-paraffin content is favourable since it increases the yield of ethylene while reducing the yields of fractions like pyoil¹, pygas² and C₄³ and resulting in less coking⁴ [22]. On the other hand, naphtha with high contents of iso-paraffins is favourable for gasoline production since it resists engine knocking and raises the octane number [23]. As a result, refineries select and process different crude oils for petrochemical production than for gasoline production.

¹Pyrolysis oil (also known as “bio-oil” or “biocrude oil”) is a dark brown liquid obtained by pyrolysis of organic materials, such as biomass or plastic waste, at temperatures of around 500 °C.

²Pyrolysis gasoline or pygas is a naphtha-range product with high aromatics content.

³Group of chemicals containing four carbon atoms, e. g. butene or butadiene.

⁴Coking refers to the build-up of elemental carbon on the furnace which must be burnt periodically to keep the process operational.

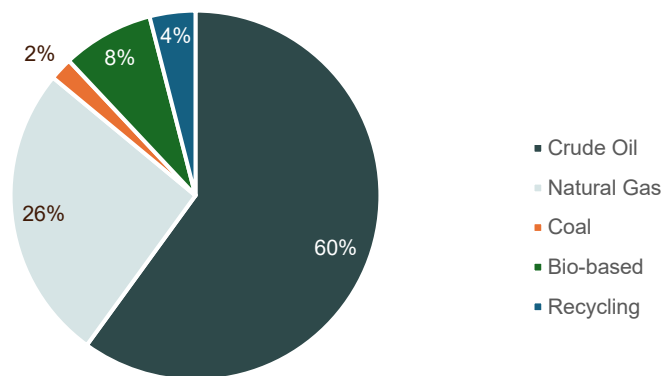

Figure 5. Global supply for embedded carbon in chemicals and derived materials by type of feedstock, reference years: 2015-2022. Own illustration based on data from [24].

The reasons for this are versatile: For some processes, transitioning to renewable feedstocks requires major technical adjustments. In other cases, processes have been optimised for fossil feedstocks and the lack of experience with the properties of new climate friendly routes or feedstocks is hindering investments. In the context of steam cracking, a feedstock transition is technically feasible with minor adjustments.

Possible climate friendly feedstock alternatives are Fischer-Tropsch-Naphtha from syngas, upgraded pyoil using biogenic or plastic waste or renewable naphtha from e. g. vegetable oil [25].

In existing plants, conventional feedstocks can be partially replaced by bio- or py-naphtha as well as by pyrolysis oil, although the latter can only substitute around 10-15 % of the feedstock without additional pretreatment. However, another issue of the renewable feedstocks is preventing operators from investing into the transformation. While steam cracker products are upstream of the value chain, they experience intense price pressure since they are lesser value products. On the other hand, the capacities of these plants are huge and stopping and restarting them is extremely expensive. Hence, security of supply is crucial for economically viable operation. While the overall (and constant) availability of alternative feedstocks is still uncertain and expected to be limited, they are expected to be much more expensive than the fossil-based feedstock which makes them unattractive in market environment where price pressure is imminent and global competition is increasing. More details and information can be found in Chapter 3.1 *Novel pathways to producing key chemicals*, p. 37.



2.1.3 Production data: 2019-2024 trends

KEY INSIGHTS

- Since 2019, steam crackers in the TCR were operated below the aspired 95 % capacity utilisation, resulting in declining olefin (ethylene, propylene) production in the region. This trend mirrors the European trend, where the average steam cracker operation rates dropped from 83 % in 2019 and to 71 % in 2024.
- The sharpest decrease in the steam cracker utilisation rates happened followed Russia's war on Ukraine and has not recovered since.
- The production of the main steam cracker products, ethylene and propylene, in Europe is demand-driven and therefore relies on the downstream sector (e. g. packaging and the automotive industry).

Since 2019, a declining trend for the production of **steam cracker products** has been observed (Figure 6). For example, ethylene production in the Netherlands decreased by 25 %, from 2,012 kt in 2019 to 1,500 kt in 2024. Similarly, propylene production in the Netherlands fell by 27 %, from 1,625 kt in 2019 to 1,189 kt in 2024. A comparable 27 % decline in propylene production is also observed for Belgium, where production volume has decreased from 1,074 kt in 2019 to 780 kt in 2024.

A slightly smaller decline is observed for **aromatic compounds**, products coming both from steam cracking and other refinery processes, in both the Netherlands and NRW (see Figure 45, Annex A, p. 4). In the Netherlands, benzene production decreased by 12 % compared to 2019, while in NRW, it declined by 17 % relative to 2020 (the data for 2019 was not available for NRW). In contrast, benzene production in Belgium was fluctuating over the past few years, with 2024 output even exceeding the 2019 level by 26 %.

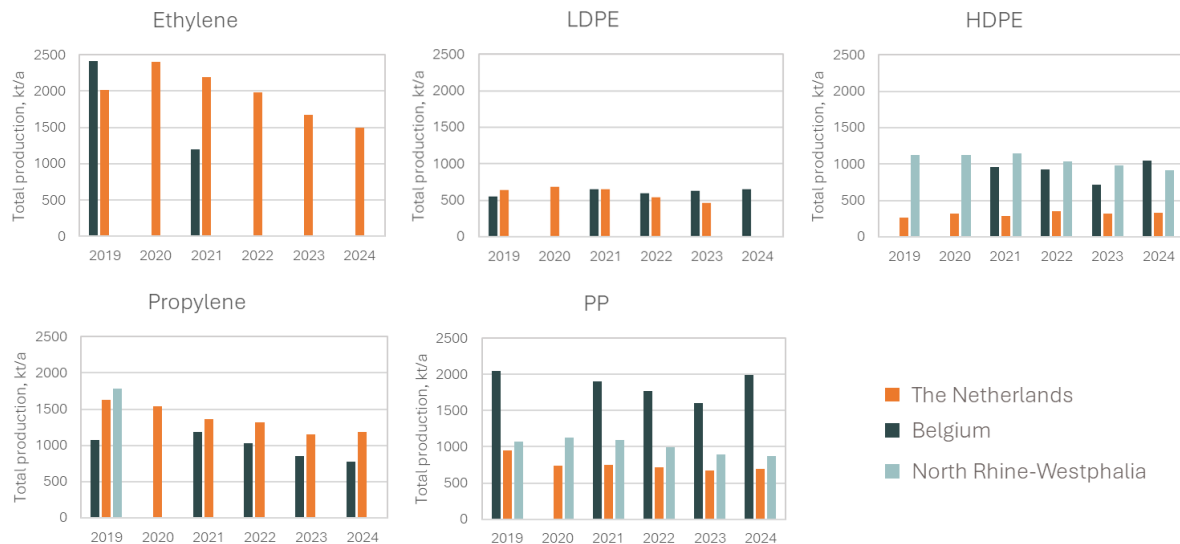

Figure 6. Total production volumes of selected commodities in the TCR from 2019 to 2024 reported in open statistical data from Eurostat and Landesdatenbank NRW [26], [27]. Missing data for a specific region or year does not indicate an absence of production of the commodity, but that the corresponding statistical data is not publicly available.



A particularly good indicator for the **steam cracker utilisation rate** is ethylene production: There is no other process of comparable significance to produce this commodity, and its fraction within the product spectrum of a steam cracker is impacted only to a limited extent by process parameters like cracking intensity or feedstock composition. The steam cracker capacity utilisation in the TCR and Germany are compared in Figure 7.

With chemical plants, a capacity utilisation of 100 % is usually not achievable due to necessary idle times for maintenance. Estimating two weeks of idle time, 95 % means that a plant was running “at full capacity” over the year.

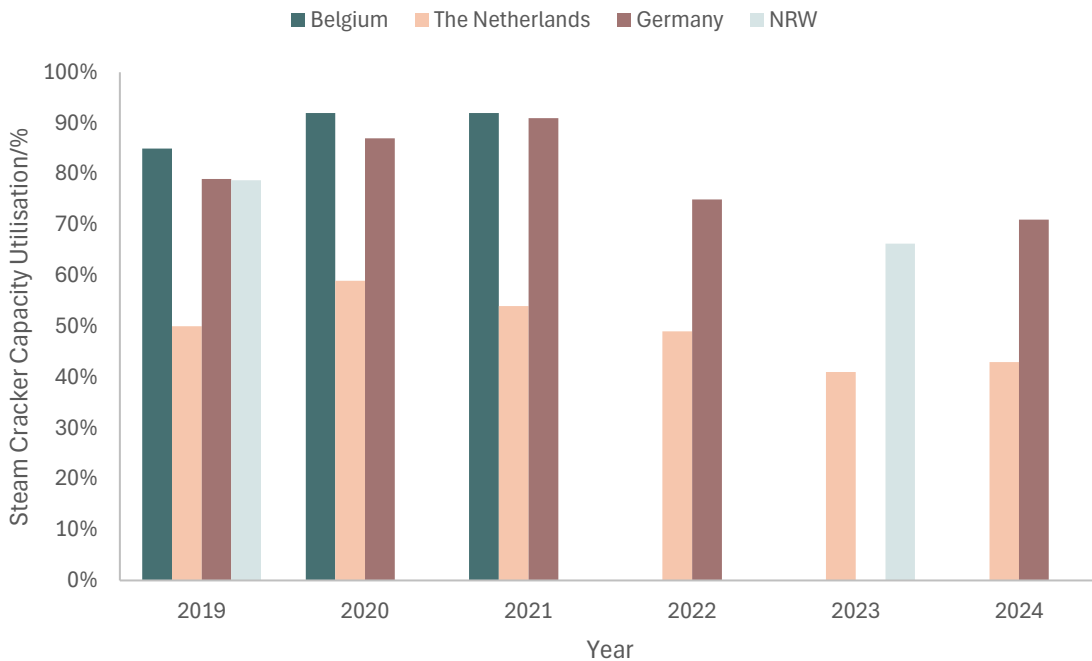

Figure 7. Estimated capacity utilisation of all steam crackers located in the TCR and Germany. The analysis for the Netherlands and Germany was based on total production data from Eurostat [26]. For Belgium and NRW, the estimation is based on emission data [28], [29] using an emission factor of 1.73 tCO₂/t ethylene [30] and information from company interviews, as the production data for these regions was limited or identified as unreliable according to stakeholder feedback. Only years with available data are shown.

Between 2019 and 2024, capacity utilisation for steam crackers in the TCR generally remained below optimal levels and a clear downward trend was observed over this period. In NRW, the average capacity utilisation of steam crackers declined from approx. 79 % in 2019 to about 66 % in 2023. The NRW numbers were estimated using emission data and information from bilateral company interviews. This data was not available for all years within the analysed period. Since a large share of German steam crackers is located in the TCR, the German data can also serve as an indicator of the expected capacity utilisation trend in NRW. The analysis of Eurostat data [26] shows that operation rate in Germany began to fall with the onset of the energy crisis following Russia’s invasion of Ukraine in 2022, dropping from 91 % in 2021 to 75 % one year later.

For Flanders, our analysis suggests utilisation of about 92 % in 2021. Emission data from the UNFCCC GHG Inventory [28] was used for this region, as Eurostat production data indicated the operation rate of about 48 % in this year, which was deemed implausible based on stakeholder feedback.



TotalEnergies, which operates two steam crackers in Antwerp with approx. 52 % of Flanders' steam cracker nameplate capacity, has recently reported average steam cracker utilisation rates of 79 % for 2024-2025 [31]. Although the figure is global and TotalEnergies operates steam crackers abroad (e. g., in France and the US), it still provides an insight on the ongoing trend. Given Europe's lower chemical capacity utilisation since 2022 compared to the US [32], it is likely that the Flemish crackers operated even below 79 % capacity. In 2020, the company reported a global utilisation rate of 83 %, rising to 90 % in 2021 [33] – in line with the trend observed in Flanders, reinforcing the comparison.

In the Netherlands, capacity utilisation of steam crackers also declined, reaching only 43 % in 2024, according to Eurostat data [26]. This correlates with the first announcement of the cracker closures in the TCR (see 2.3.1 *Evolving industrial landscape in the TCR: plant closures and new projects*, p. 28) coming from the Netherlands. The first closure in Q2 2024 (Geleen), however, did not lead to a significant improvement of the Dutch capacity utilisation. One might assume that these closures would lead to increased imports of cracker products from Flanders, North Rhine-Westphalia or regions outside the TCR. However, our analyses did not reveal any such trends (see following Chapter 2.2.1 *Trade balances: current state and 2019-2024 trends*, p. 15). This interpretation of the observations is subject to a high level of uncertainty by incomplete publicly available data.

The negative trend in capacity utilisation in the TCR mirrors the decline in ethylene and propylene production across Europe. Figure 8 and Figure 9 display the development of the European production of ethylene, propylene and benzene in recent years in comparison to the corresponding car production and the crude oil price. The graphs show that whereas the capacity utilisation for European steam crackers was around 83 % in 2019, it declined to 71 % in 2024. The comparison with the car production and oil price was done to demonstrate whether the changes in production volumes of these commodities are supply- or demand-driven. Note that the capacity utilisation of European steam crackers is represented by the ethylene capacity utilisation while benzene and propylene capacity utilisations not only stand for steam cracker operation rate but also indicate to what extent refineries were operated since both products also come from other processes.

While oil prices have shown substantial volatility over the past decades, tripling after the start of the Iraq War in 2003 and dropping by a third in the aftermath of the 2008 financial crisis, steam cracker capacity utilization has remained largely unaffected by these crises. This situation appears to have changed in 2022 with the onset of the Russian war against Ukraine. Since then, ethylene production in Europe has steadily declined, and several steam crackers across the continent have announced closures (see Chapter 2.3.1 *Evolving industrial landscape in the TCR: plant closures and new projects*, p. 28). This development is particularly noteworthy considering that Figure 8 and Figure 9 show capacity utilization, meaning that the actual decline in ethylene production is even more pronounced than the graphs suggest, as the closure or temporary idling of steam crackers in the region has reduced overall capacity. Propylene capacity utilization largely mirrors that of ethylene, as most propylene in Europe still originates from steam cracking (approx. 69 % in 2024 [18]). However, this situation may change as more ethane crackers, such as INEOS's Project ONE, enter the market and displace naphtha-based crackers. If propylene demand remains stable, additional production capacity from alternative routes such as PDHs or FCCs would be required.

Benzene production, by contrast, appears to be more directly influenced by oil price fluctuations. This is likely because a substantial share of benzene on the market does not originate from steam cracking but from refinery processes (approx. 40 % in 2024 [18]), making its pricing more closely linked to crude oil and less correlated with that of ethylene.

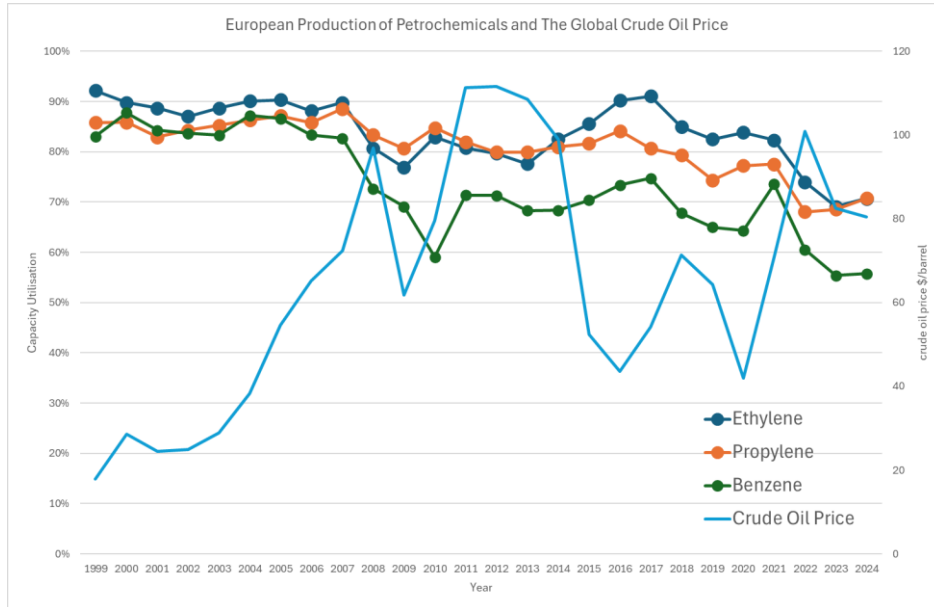

Figure 8. European production of ethylene, propylene and benzene from 1999 to 2024 and average annual crude oil prices over the time period. Source of crude oil prices [34]. Production numbers from [18].

When comparing the annual number of cars produced in Europe with olefin (ethylene and propylene) capacity utilization, similar trends can be observed. This is unsurprising, as the automotive sector is one of the key downstream consumers of polymers and other chemicals derived from olefins. Figure 8 and Figure 9 highlight, that production of the steam cracker products is mostly demand and not supply driven.

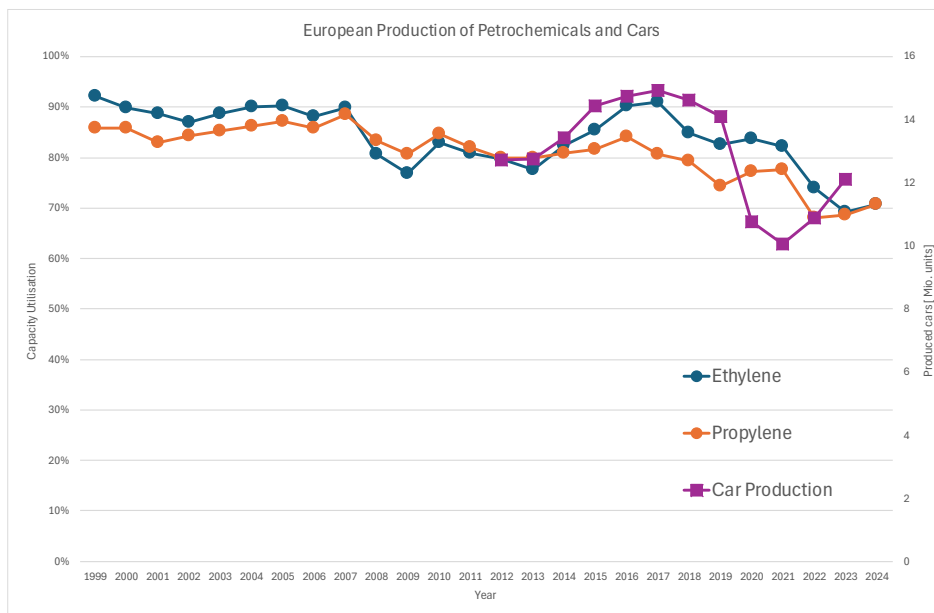

Figure 9. Car production and ethylene and propylene production from 1999 to 2024 in Europe. Source of car production [35], ethylene/propylene production numbers from [18].



In comparison to olefins, the production of **polymers** demonstrates a more heterogeneous dynamic, varying by both commodity and region (Figure 6). In Belgium, production volumes of the analysed polymers (LDPE, HDPE, and PP) remained relatively stable. Although they fluctuated throughout the years, by 2024, they had recovered to early-2020s levels. In contrast, production in NRW declined substantially: HDPE output fell by 19 % (from 1,126 kt to 915 kt) and polypropylene production by 23 % (from 1,072 kt to 869 kt) in 2024 compared with 2019. In the Netherlands, LDPE production decreased by 28 %, while PP output dropped by 26 %. Conversely, HDPE production remained relatively stable, and production of Linear Low-Density Polyethylene (LLDPE) increased (see Figure 45, Annex A, p. 3). Overall, although olefin production in the TCR is declining, the available data are insufficient to establish a robust correlation with shifts in the production of specific polymers.

Ammonia is produced at four sites in the TCR (Antwerp, Dormagen, Geleen and Sluiskil) with a total nameplate capacity of approx. 3.9 Mt/a. The Netherlands accounts for the largest share (around 74 %) with OCI Nitrogen's plant in Geleen and Yara's major complex in Sluiskil (1.9 Mt/a). **Methanol** production in the TCR is more limited. In 2019, three sites produced methanol with a total nameplate capacity of about 1.7 Mt/a: BP's refinery in Gelsenkirchen, Shell's refinery in Wesseling, and OCI's larger plant (1 Mt/a) in Delfzijl (acquired by Methanex in June 2025) [36]. However, production at Delfzijl is not in operation since 2021 due to unfavourable natural gas prices, and the Wesseling site was permanently closed in 2024 [37], leaving around 280 kt/a of methanol production in NRW. Although recent production data for methanol and ammonia is not publicly available, capacity utilisation here is likely to have been below optimal levels in recent years, similar to the trend observed for steam crackers.

2.2 Trade flows between regions

2.2.1 Trade balances: current state and 2019-2024 trends

KEY INSIGHTS

- Depending on the commodity group, the TCR had different trade balances in 2024:
 - Net importer of olefins, with country-specific variations: Belgium – heavy importer of ethylene and propylene, the Netherlands – significant net exporter of olefins.
 - Overall, the TCR is a net exporter of polymers.
 - The region was a net importer of ammonia and methanol: while ammonia is imported primarily for domestic consumption, over 60 % of methanol is re-exported in Belgium and the Netherlands, positioning the major ports in the TCR as a transit hub.
- Since 2019, overall decrease of trade flows, both imports and exports, is observed. A general decline in polymer net exports, particularly in NRW, is seen, which can be attributed to lower local demand, as well as weaker demand in the rest of Germany.
- While there are no significant net imports of polymers in primary form from China to the TCR, large volumes of finished consumer goods are entering the European market. This can result in a decrease in local polymer demand and impact upstream and downstream industries negatively.

The trade flows of analysed commodity groups for the BE-NL-NRW are shown in Figure 10. Since no detailed statistical data for Flanders was available, data for Belgium was used instead. This data can however still serve for derivation of reasonable conclusions for the TCR, given that all Belgian steam crackers are located in Flanders and that the region accounts for approx. two-thirds of the total turnover of Belgium's chemicals, plastics, and life sciences sector [38].



In 2024, the BE-NL-NRW region was a net importer of olefins (ethylene and propylene) with a net import balance of approx. 340 kt. The trade in these products is characterised by substantial export and import flows between the three regions (see Chapter 2.2.3 *Main trade partners*, p. 21 for more details). At the same time, the BE-NL-NRW had a significant trade surplus of around 3,556 kt for polymers (polyethylene, polypropylene, and PVC) which are mostly exported to other EU countries. For other analysed bulk chemicals (ammonia and methanol), the region was a net importer, with a trade deficit of 383 kt for ammonia and 2,348 kt for methanol.

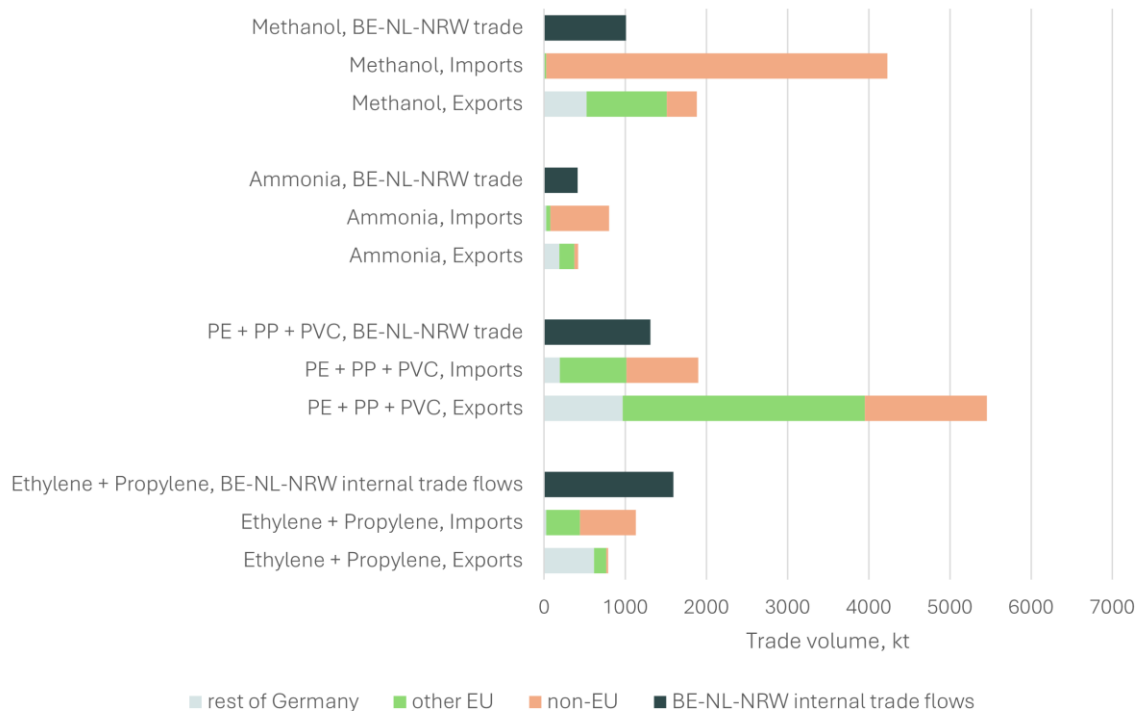
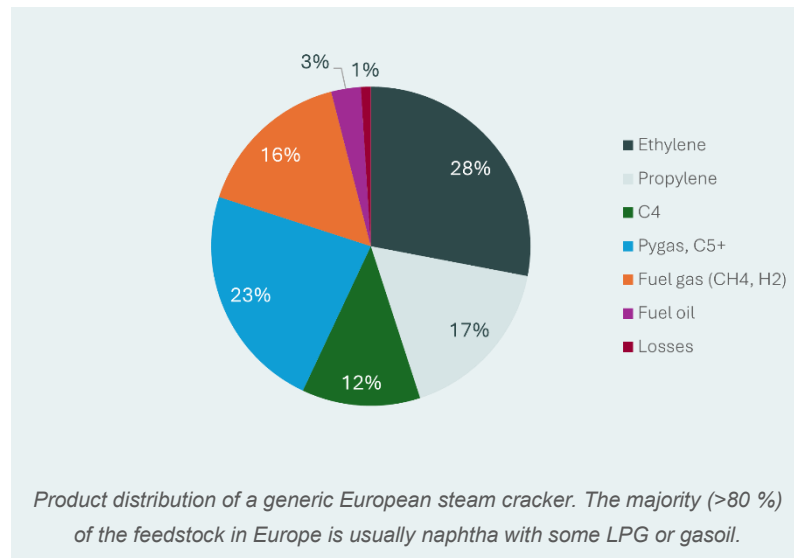

Figure 10. Exports, imports and regional trade volumes for olefins, polymers and other bulk chemicals (methanol and ammonia) for the BE-NL-NRW region in 2024, based on data from [27] and [39]. The BE-NL-NRW trade was estimated as the sum of the volumes traded between Belgium, the Netherlands, and North Rhine-Westphalia. Does not include the trade flows between North Rhine-Westphalia and Germany, as the data is not available in the statistics.

The trade data for individual regions highlights several country-specific variations (Figure 11). In the case of **olefins**, Belgium was overall a net importer of both ethylene and propylene in 2024. For instance, the net import of ethylene in 2024 was 1,055 kt, in contrast to the Netherlands (net export of 712 kt) and North Rhine-Westphalia (net export of 67 kt). Belgium's net imports for propylene were much smaller (209 kt) but still notable, whereas both the Netherlands and North Rhine-Westphalia were net exporters of this product, with 457 kt and 21 kt, respectively. The generally lower amounts of propylene compared to those of ethylene in the trade balances and production data are in agreement with the average steam cracker output. A comparison between the exported volumes of the analysed commodities and domestic consumption of olefins shows (Annex A, Table 7, p. 3) that in the Netherlands, the volumes of ethylene and propylene for exports and domestic consumption are of similar magnitude. In contrast, in Belgium, the domestic market is crucial for the local steam cracker operations, since exports of these commodities from Belgium are negligible. Our analysis of trade data did not indicate any statistically significant impact of the plant closures that occurred before 2024 on the imports or exports of the commodities under investigation. One might assume that the European overcapacities would fill these gaps [40]; however, there is insufficient data to verify this assumption.



While being a net importer of olefins as feedstocks, Belgium appears to have a viable polymerisation hub, converting imported and locally produced olefins and acting as a net exporter of **polymers**: PE (net export of 562 kt LDPE and 297 kt of HDPE), PVC (net export of 264 kt), and PP (net export of 160 kt) in 2024. The comparison between the trade and production data demonstrates that HDPE production is more export-oriented (Table 7, Annex A, p. 3) than PP production in Belgium. The same is observed for the Netherlands. For PP, the volumes consumed at the domestic markets are higher than exports for all three regions.

For HDPE and PP produced in NRW, the domestic consumption (within NRW and the rest of Germany) is approximately twice as high as the exports to other countries that demonstrate a crucial role of the German polymer market for the region.

In comparison to other parts of the TCR, the Netherlands exhibited higher net exports of **aromatics** in 2024. Specifically, net benzene exports amounted to 699 kt, and p-xylene exports reached 222 kt, while toluene showed net imports of 83 kt.

Trade balances in 2024

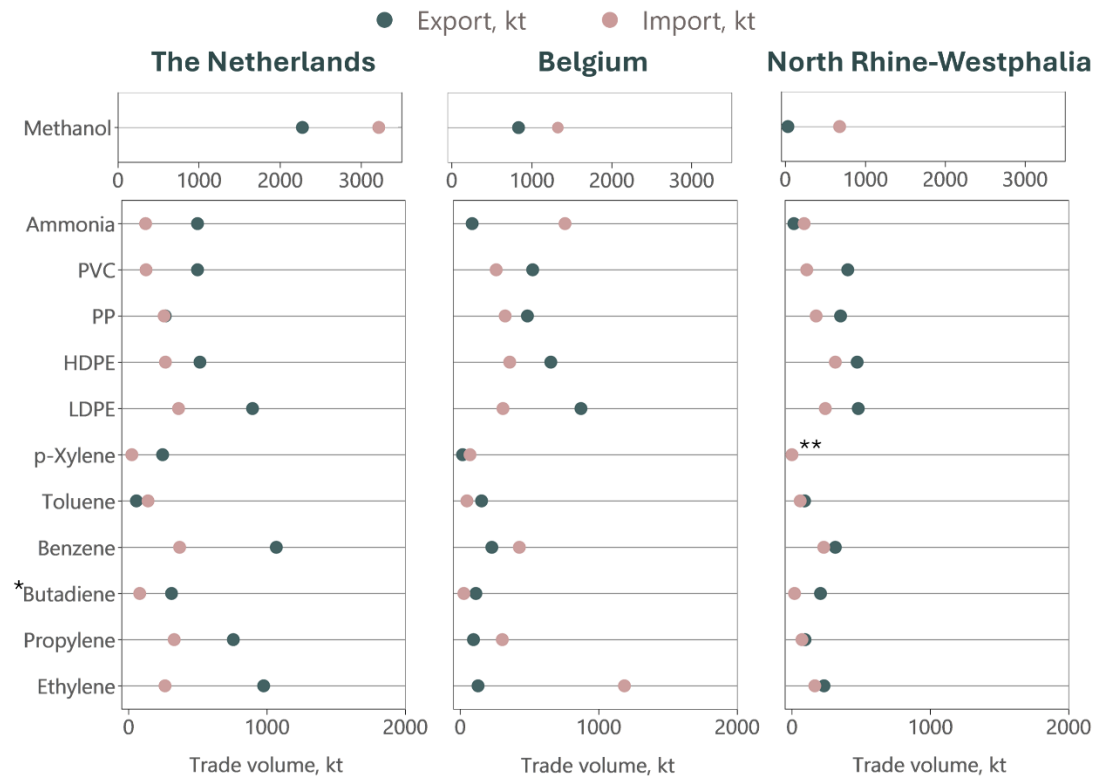

Production in 2024

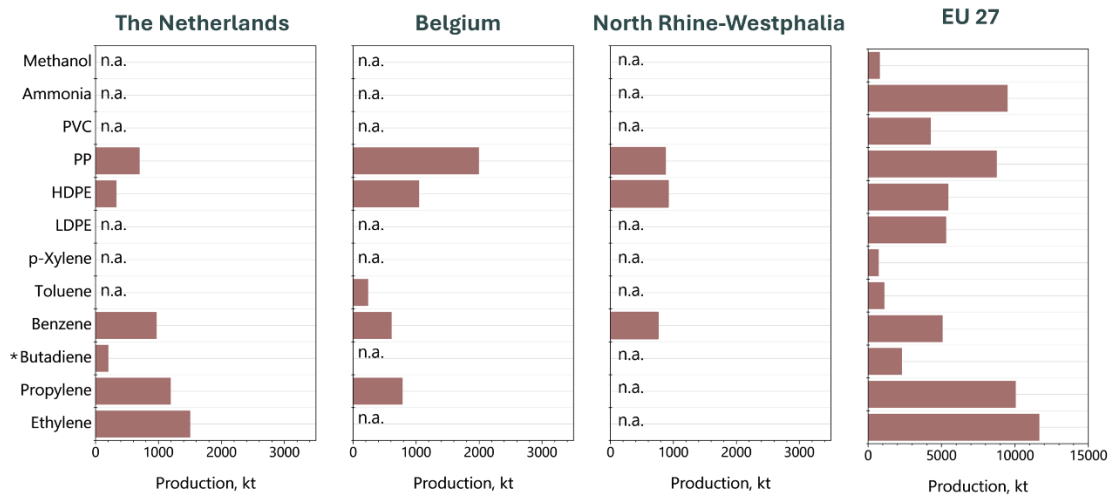

*HS 2901214: Acyclic hydrocarbon; unsaturated, buta -1,3- diene and isoprene (Comtrade) or 20141160 Buta-1,3-diene and isoprene (Eurostat)

** Export data not available

Figure 11. Comparison of the trade (export and import) and production data in Belgium, the Netherlands and NRW in 2024. Based on [26], [27], [39]. Does not include the trade flows between North Rhine-Westphalia and Germany, as the data is not available in the statistics.



On the regional level, only the Netherlands are a net exporter of **ammonia**. In case of **methanol**, both high import and export flows can be observed in Belgium and the Netherlands. Given that methanol production within the TCR accounted for only about 280 kt/a nameplate capacity by the end of 2024, and was located in the NRW (see Chapter 2.1.3 *Production data: 2019-2024 trends*, p. 11), this highlights the role of the Belgian and Dutch ports as major transit hubs for this commodity.

An analysis of the UN Comtrade data demonstrates that in 2024, Belgium, the Netherlands and North Rhine-Westphalia imported approx. 4,200 kt of methanol from non-EU countries. At the same time, Eurostat data indicate that the total EU27 methanol imports were approx. 6,300 kt during the same period. This suggests that roughly 67 % of the total EU27 import entered the continent via the TCR.

In contrast, imported ammonia largely remains within the region, as exemplified by the case of Belgium. This high level of domestic ammonia consumption in Belgium can be attributed to its substantial fertiliser production [41]. In 2019, almost one-third of Belgian fertiliser exports were destined to France (2,200 kt) [42].

2.2.2 Influence of recent political developments

The last five crisis years have not passed without affecting trade flows in the region. Our analysis of net trade flows shows that, when comparing 2019 data to recent numbers from 2024, both exports and imports have decreased in size. This trend is clearly visible in comparison of the net trade flow diagrams (Figure 46, Annex A, p. 4).

The developments for individual product groups observed in the last years differ across the three regions (Figure 12). Positive values indicate net exports of a commodity while negative values indicate an import surplus. NRW faced dropping net export quantities across all analysed commodity groups. In particular, net polymer exports from NRW to the markets outside the TCR have seen a drastic decrease over the past five years.

- PE: -92 kt or -20 % to other EU countries, -96 kt or -36 % to non-EU countries;
- PP: -85 kt or -34 % to other EU countries, -82 kt or -92 % to non-EU countries.

At the same time, total export of olefins, as well as polymers from the Netherlands increased from 2019 to 2024. An interesting observation is that, while the Netherlands' 2024 net exports of ethylene to NRW were below the amount of 2019 (-70 kt), this was over-compensated by increased exports to Belgium, the rest of Germany and other EU countries (+235 kt) (Figure 46, Annex A, p. 4). Furthermore, net trade surplus for aromatics reported by the Netherlands have been increasing since 2022, driven by rising export volumes, while import levels have remained relatively stable. The trend may be explained by a decline in local demand, following the closure of styrene and cumene plants in the Netherlands in 2023 and another cessation of propylene oxide-styrene production announced in 2026 (see Chapter 2.3.1 *Evolving industrial landscape in the TCR: plant closures and new projects*, p. 28). The cumene plant alone has a nameplate capacity of 735 kt/a [43] and thus required up to 480 kt/a of benzene feedstock. Another factor may be the shift in crude oil origin processed in the EU: in 2023, imports from Russia declined by 84 % compared to 2020, compensated by imports from other regions, for instance, from Norway [44]. The naphtha fractions of the crude oil from some Norway's reservoirs are rich in aromatics [22], potentially affecting benzene yield in refineries and steam crackers.

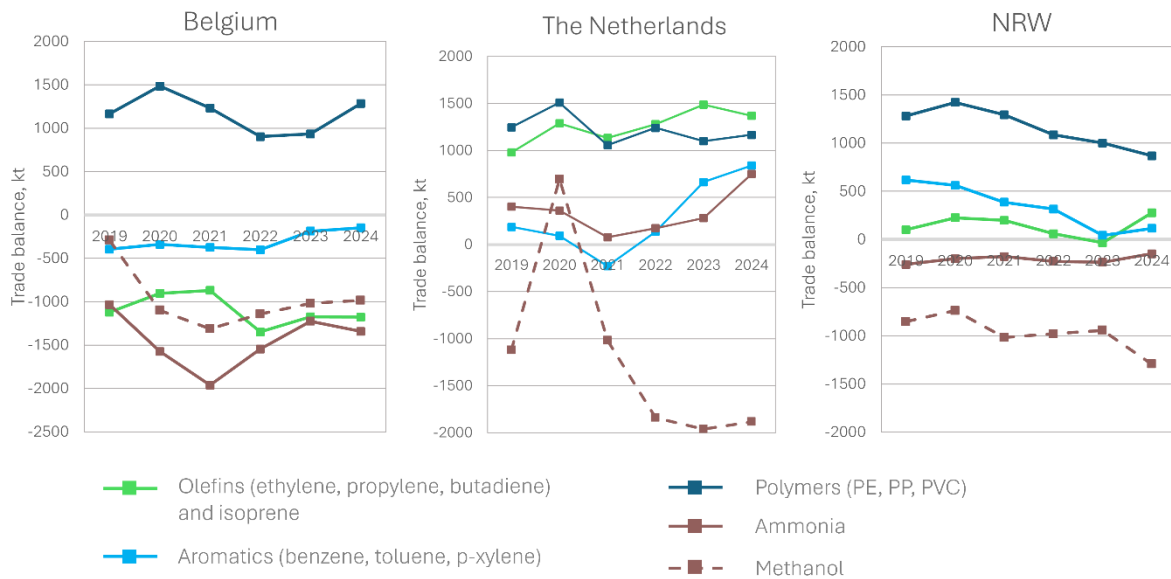

Figure 12. Trends in trade balances for analysed commodities in 2019-2024. Positive values indicate net-exports of a commodity while negative values indicate an import surplus. Based on the data from [45]. Does not include the flows between North Rhine-Westphalia and Germany, as the data is not available in the statistics.

The changes in trade flows observed in recent years were not limited to the TCR. Since the three countries within the TCR display distinct trade dynamics, their flows were also assessed separately. Germany, as a major trading partner of the region, has been affected as well. In 2019, Germany was a net importer of propylene from other EU member states (115 kt) (Figure 46, Annex A, p. 4) with the largest net imports originating from Portugal and Spain. The highest single net import volume of propylene to Germany, however, came from the Netherlands (184 kt). By 2024, Germany had become a net exporter of this commodity to the rest of the EU, a shift driven by both increasing export volumes and declining imports. Imports of ethylene to Germany also decreased over this period. Imports of olefins from non-EU countries (United Kingdom, Norway, and the US) to Germany (excluding NRW) also declined sharply by 2024. Net ethylene imports fell from 161 kt to 42 kt (-74 %), while net propylene imports decreased from 204 kt to 24 kt (-88 %). Another indication of weakening demand in Germany was the reduction in net exports of PE and PP from Belgium and the Netherlands. These trends can likely be attributed to the ongoing crises of the German automotive and building sectors, which represent major downstream consumers of these polymers. In 2019, Germany (excluding NRW) recorded net PE imports of 816 kt; by 2024, this figure had dropped to 652 kt (-20 %). However, for Belgium and the Netherlands, these reduced exports to Germany were largely offset by increased shipments to other regions.

In general, the trade data analysis demonstrates that the decline in polymer production observed in the TCR, for instance, in the Netherlands or North Rhine-Westphalia, appears to be primarily driven by weakening local demand. Neither our data nor that of other sources, such as Plastics Europe, show high import flows of olefins or polymers in primary form from China to Europe. However, as established earlier (see Figure 9), olefin production is fundamentally consumer-driven. Although not analysed in detail, as it is beyond the scope of this study, it is evident that China exports large volumes of plastic-based consumer goods to Europe [16]. The entire value chain of these products typically lies outside the EU. Nevertheless, it remains uncertain, whether European consumers would purchase similar quantities of such products, e. g. plastic table ware, if they were sold at prices reflecting European production costs. However, these imports are expected to exert at least some influence on the European market. The example of China illustrates that it is not only individual segments of the value



chain that are at risk of relocation, but in some cases whole production lines from olefin to polymer to finished plastic products such as plastic toys are gradually shifting outside of Europe.

For the other analysed commodities, a spike in net trade balances for methanol was observed in 2020. This development resulted from reduced imports, while exports remained relatively stable. It may be associated with weaker demand for downstream methanol derivatives such as formaldehyde or MTBE during the pandemic. The net trade balance turned negative again in 2021 and declined further in 2022, consistent with the closure of OCI's large methanol plant in Delfzijl in June 2021 [46]. This event likely contributed to the subsequent increase in net imports.

2.2.3 Main trade partners

KEY INSIGHTS

- For the analysed commodities, the intensity of two-way trade is particularly strong at the TCR level. This highlights the vital role of a highly integrated infrastructure network within the region to enable this trade.
- Steam cracker products are commonly traded on regional markets.
 - Some products, such as benzene and C4, are also attractive for non-European countries.
 - Reduction of the steam cracker capacities would probably not lead to higher imports of ethylene/propylene but lead to increased imports of the downstream products.
- Over 70 % of exports of analysed polymers were for the European market. This underscores both the significance of the domestic European market for the TCR, as well as the importance of the TCR-based polymer producers for the customers across Europe.
- Ammonia and methanol, the other key bulk chemicals, are currently largely imported into the TCR from non-European suppliers. The reliance on only few critical trade partners combined with an unstable geopolitical environment, highlights the need to maintain strategic production capacities, develop diversification strategies, and ensure infrastructure that enables a rapid shift to alternative suppliers within the TCR.
 - In 2024, just two countries accounted for about 71 % of total imports of methanol into the BE-NL-NRW region: the USA (37 %) and Trinidad and Tobago (34 %). For ammonia, three countries supplied 78% of the region's imports: Russia (42 %), Trinidad and Tobago (23 %), and the USA (13 %).

The products of the chemical industry in the TCR are traded with various partners: local companies, companies in neighbouring countries, situated in other European countries or across the world.

The regional distribution of trade flows for analysed commodities in the Netherlands, Belgium and NRW is presented in Figure 10, p. 16. In 2024, the local trade within the BE-NL-NRW region accounted for the following shares:

- Olefins (ethylene and propylene): 67 % of exports and 58 % of imports,
- Polymers (PE, PP, PVC): 19 % of exports and 41 % of imports,
- Other bulk chemicals: 50 % of exports and 34 % of imports for ammonia, and 35 % of exports and 19 % of imports of methanol.

This underscores the intense trade interconnections between Belgium, the Netherlands, and NRW. For exports, both the EU and Germany (excluding NRW) served as key trading partners, together representing 52 % of total exports for the analysed commodities. In contrast, non-EU countries played a more significant role on the import side, particularly due to ammonia and methanol, which were imported in large volumes.



Based on the available trade data statistics [45], we identified ten main partners for the analysed commodities traded with the Netherlands (Figure 13), Belgium (Figure 47, Annex A, p. 5) and North Rhine-Westphalia (Figure 48, Annex A, p. 6), summarised on the corresponding maps. All maps, both for export and import flows, reveal a common feature: a bright spot in Northwest Europe, indicating the high intensity of trade flows (in value terms) among the three countries. Across all three regions, and for nearly all analysed commodity groups, each TCR country counts the other two among its top three trading partners. This highlights the critical role of intra-regional linkages for companies across the steam cracker value chain.

More specifically, trade data show that **olefins** are predominantly traded at the regional (TCR) level. The active two-way trade between Belgium, Germany, and the Netherlands is remarkable, with the shares of the TCR in absolute exports and imports commonly being close or even above 50 %. Such strong trade flows are only possible due to the well-developed infrastructure (particularly pipeline networks for olefins, see Figure in the infobox below) and the logistics routes established over decades. It is important to note, that steam cracker products are, in general, mostly traded on regional markets globally due to the transport and logistics limitations.

Besides the trade flows between the TCR countries for these commodities, also the United Kingdom used to play an important role as a supplier of olefins for the TCR. For instance, the Netherlands are sourcing approx. 20 % of analysed olefins from the United Kingdom, for Belgium this was approx. 18 %. This, however, may change in the future: in the beginning of 2026, one of the two remaining steam crackers in the United Kingdom is scheduled to be shut down, removing more than half of the country's ethylene production capacities [47].

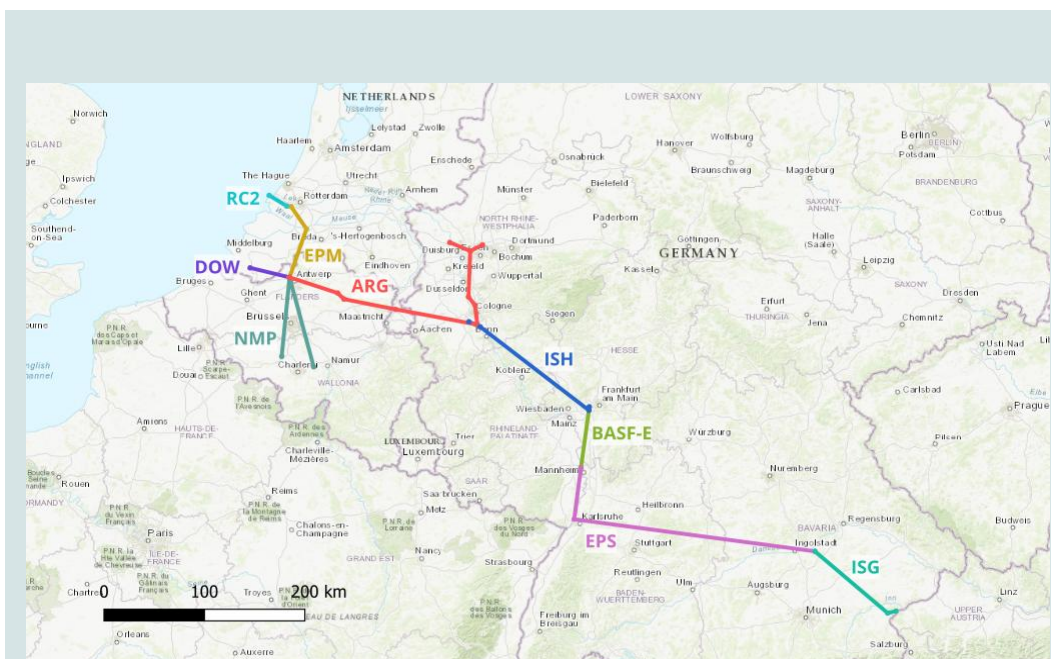

The lifeline of the region's chemical industry is the 495-kilometre ARG pipeline, an ethylene pipeline which links the ports of Rotterdam and Antwerp with cracker operators and chemical production sites across the Netherlands, Flanders, and North Rhine-Westphalia. Propylene pipeline networks are also in place in the three considered countries. However, there is currently no cross-border propylene pipeline. Further information about the fossil-based pipeline system and its potential repurposing in the context of the energy transition can be found in [20].

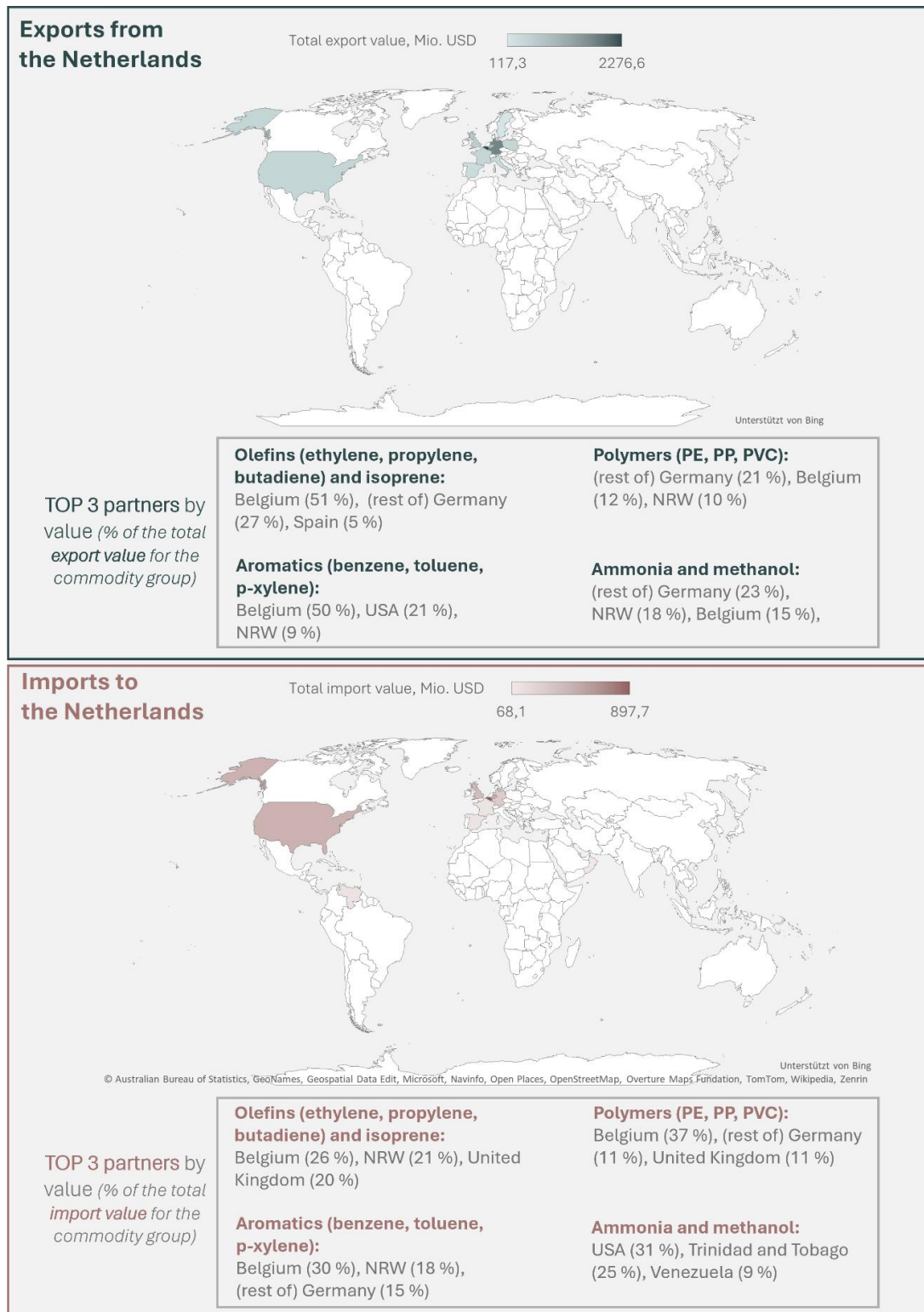

Figure 13. Ten main import and export partners of the Netherlands in 2024 for the analysed commodities. Based on the data from [45]. See Annex A for Belgium (Figure 47, Annex A, p. 5), North Rhine-Westphalia (Figure 48, Annex A, p. 6) and methodology. Does not include the flows between North Rhine-Westphalia and Germany, as the data is not available in the statistics.



On the export side, an interesting product group in terms of trade partner engagement are C4 products (butadiene, butene) and isoprene. In 2024, the TCR regions each focused on different key export markets (Figure 14). In the case of NRW, the EU market – particularly France, which accounts for approx. half of NRW's net C4 exports in 2024 – is of critical importance. In contrast, Belgium exported significant volumes of C4 products to non-EU destinations, with Saudi Arabia alone receiving around one-third of Belgium's total net exports. The Netherlands distributed a major part of its net C4 exports across the following countries: China, Spain, France, and rest of Germany.

Aromatics are also traded largely within the TCR but are additionally exported overseas, for example to the US, which accounted for 21 % of the Netherlands' total aromatic exports and 18 % of Belgium's in 2024. The analysis of the net trade balances shows that in 2024, over half of the Netherlands' net exports of p-xylene and approximately one-fifth of its benzene exports were destined for the US. This, as well as the exports of C4 products, can be explained by the differences in cracker feedstocks typically used in various regions around the world. These feedstocks are more cost competitive in terms of ethylene but do not yield heavier products like butadiene or aromatics.

While European steam crackers are mostly designed to crack naphtha, a heavy crude oil fraction, it is not like this in all countries around the world. Worldwide, half of ethylene is produced by naphtha steam crackers while the other half originates from ethane cracking [20]. Currently, the crackers in Middle East and the USA are mostly run on lighter feedstock (ethane, LPG), while in the Asia-Pacific region naphtha is the most common feedstock. Currently, there is a global trend on applying lighter feedstocks like ethane, which yields cheaper ethylene (price difference to naphtha-based ethylene: 200 USD/t-400 USD/t [17]) but is lacking other products like propylene, C4 and aromatics. This trend towards lighter feedstocks for olefin production can be observed on the example of Chinese capacity expansion [48] as well as in Europe's new steam cracker in Antwerp (Project One by INEOS [49]). The old European steam crackers are designed for a specific density of feedstock, which makes switching to lighter feedstocks possible only after refurbishments.

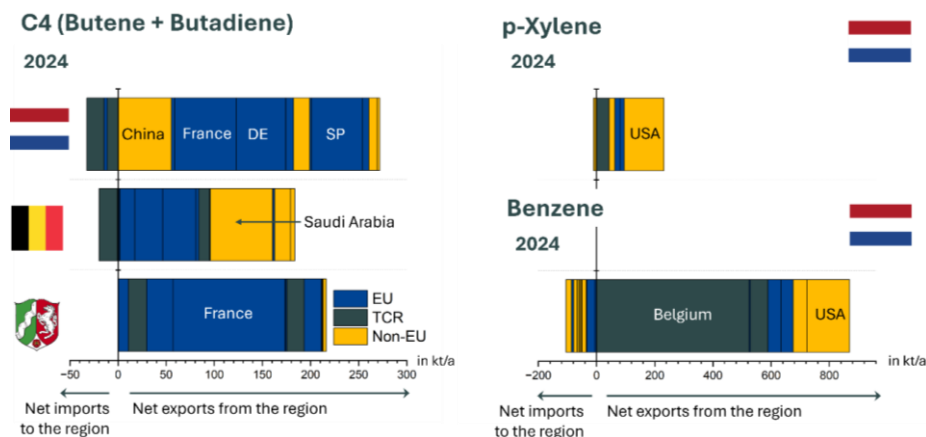

Figure 14. Net trade balances for C4 products in BE-NL-NRW in 2024, and for benzene and p-xylene in the Netherlands in 2024. The analysis does not include the flows between North Rhine-Westphalia and Germany, as the data is not available in the statistics.

For **polymers**, the market is more diversified. However, most products from the TCR are sold within the European market, pointing out the importance of the domestic European demand for the chemical industry in the TCR. On the other hand, the TCR is an important supplier of polymers to other European

countries. PVC stands out for being significantly traded with non-EU partners. For instance, the United Kingdom accounts for 19 % of the Netherlands' PVC exports, while Türkiye represents a major single destination for Belgium's with 22 % of export flow.

It is worth noting that NRW exports much bigger volumes of the analysed products than it imports while the opposite can be said about Germany. In 2024, NRW exported almost as much PE and PP to other European countries (approx. 1,300 kt) as the combined imports of these products to Germany accounted for (approx. 1,800 kt). Considering the size of NRW and it only being one of Germany's major chemical hubs, this is remarkable.

Other **bulk chemicals** such as ammonia and methanol largely explain the presence of non-European countries on the maps of the main trade partners. In 2024, the Netherlands were the only net ammonia exporter within the TCR, supplying both the EU and the TCR markets, while all three regions were net importers of methanol. Methanol adds South American countries such as Trinidad and Tobago and Venezuela, as well as the US, or Middle Eastern partners (e. g. Oman), to the list of the main trade partners. For ammonia, also Russia can be added. The net trade flow of ammonia from non-EU countries to Belgium were the largest net trade flows in terms of volume in 2019 (Figure 46, Annex A, p. 4).

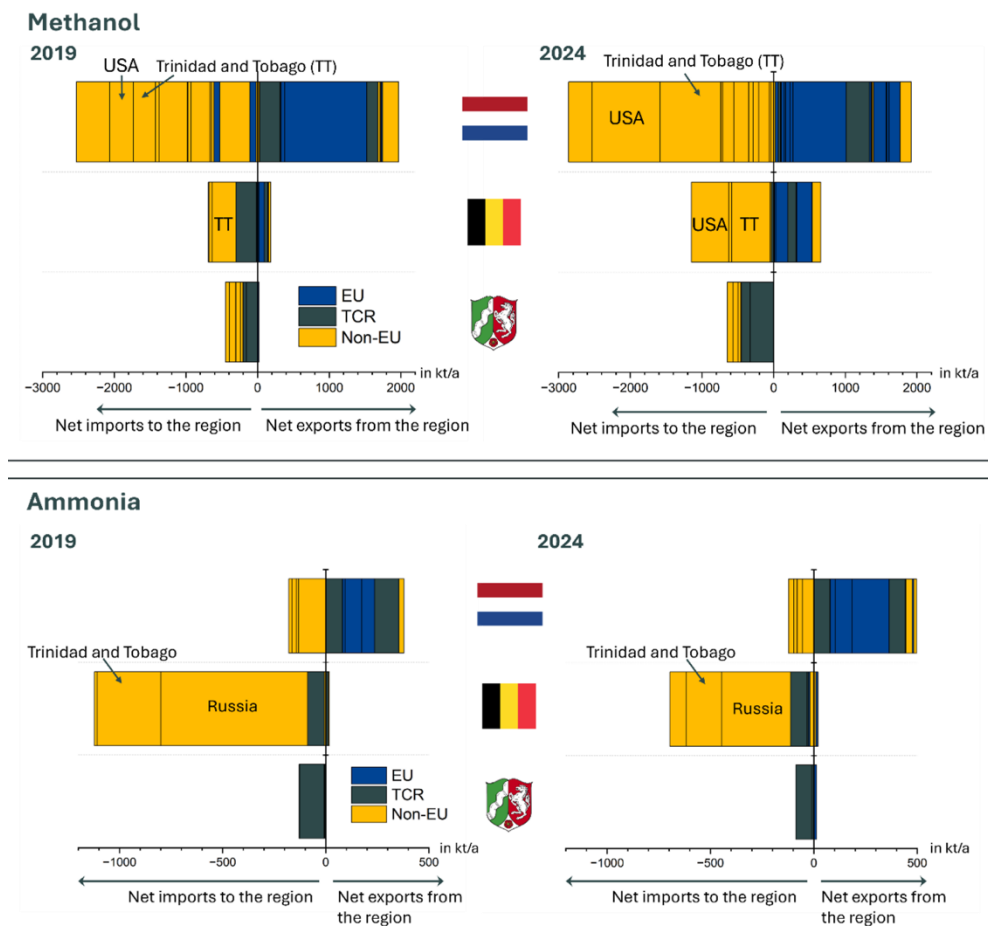

Figure 15. Net trade data analysis: distribution of the net exports and imports over different trade partner groups for methanol (above) and ammonia (below). Based on the data from [45]. The analysis does not include the flows between North Rhine-Westphalia and Germany, as the data is not available in the statistics.



Our analysis of net trade flows demonstrates that the share of the US in methanol imports increased significantly over recent years (Figure 15). Trade data also indicates that large volumes of methanol enter Europe through Dutch ports, as the Netherlands re-export significant quantities. On the one hand, the good infrastructure and high level of integration allow for efficient transport and re-distribution, but the dependencies on non-EU suppliers remain.

Another observation from the net trade data analysis presented in Figure 15 is that, in some cases, only a few non-EU partners account for a large share of total net imports. In 2024, just two countries accounted for about 71 % of total imports of this commodity into Belgium, the Netherlands, and NRW: the US (37 %) and Trinidad and Tobago (34 %).

For ammonia, three countries supplied 78 % of the region's imports: Russia (42%), Trinidad and Tobago (23 %), and the US (13 %). Belgium's large volumes of ammonia imports are due to its significant fertiliser production that is an important supply source for Europe [41], [42]. The strong reliance on only few partners makes the supply of these key bulk chemicals vulnerable to an unstable geopolitical environment. At the same time, it highlights the importance of maintaining strategic production capacities within the TCR and in Europe in general, to ensure resilience against potential market disruptions or political shifts in major supplier countries.

2.3 Competitiveness of current value chains

KEY INSIGHTS

- Announced plant closures, resulting from the ongoing industry crisis and strategic portfolio reviews, have affected companies across multiple segments of the chemical value chain in the TCR, including upstream operations (refineries and steam crackers), intermediates production, polymers and specialty chemicals, as well as mechanical polymer recycling.
- For steam crackers, announced closures amount for 17 % of the total TCR's ethylene capacity. Rising global overcapacity and the commissioning of new plants operating with lighter feedstocks will put additional pressure on the TCR's conventional steam cracker operators.
 - The current production costs of European ethylene depend largely on the price of feedstock and are higher than in other parts of the world. This is one of the factors that negatively impacts the cost competitiveness of steam crackers in Europe.
- The closure of individual plants at integrated industrial sites cannot be viewed in isolation, as it increases risks for both downstream and upstream partners, as shown by recent examples in the TCR. However, it is hard to predict if a specific closure will result in a "domino effect" rippling through the value chain or if the impact is a change of supplier.
- Most large projects in the TCR that recently began operations or are nearing completion were decided before the current crisis. New, large-scale investments today appear more challenging. Some companies which are also located in the TCR invest abroad, driven by factors such as lower energy and feedstock prices or higher expected market demand.
 - The example of chemical recycling projects show that companies often begin with smaller-scale plants to test commercial viability before committing to a large-scale alternative production route.

The upstream sector with a high energy demand and high volumes of processed feedstocks which includes steam cracker production, has been particularly affected by the rising production costs. According to data from Cefic and ICIS [50], the ethylene cash costs for European steam crackers reached 885 USD/t in 2023, or approximately 850 EUR/t in 2025³. This cost is more than three times higher than in North America (281 USD/t in 2023) and about 2.5 times higher than in the Middle East

³ 1 EUR = 0,924 USD in 2023. EUR 2023 to EUR 2025 = x1,04



(348 USD/t). The feedstock price is the primer cost driver for conventional steam cracking and is, therefore, the main reason for the regional differences. The use of lighter and cheaper feedstocks, such as ethane, leads the final ethylene costs. The European producers however largely rely on naphtha as described in Chapter 2.2.3 *Main trade partners*, p. 21.

For the facilities that are using naphtha as their main feedstock, the production cost gap is relatively low as shown by the analysis in Chapter 3.5.2 *Competitiveness comparison in a global policy context*, p. 70 for Europe and China. However, CO₂ costs differ for Europe compared to other regions and add a substantial extra share to the production costs.

The deterioration of cost competitiveness, together with global overcapacities, weak local demand, and stringent regulatory frameworks, has already triggered an alarming wave of capacity reduction in European chemical sector. This trend poses a threat to jobs, welfare creation, know-how and impacts other actors across the value chain.

Figure 16 below shows the distribution of steam cracker products. The lighter inner circle represents the weight distribution of products (in t) coming, on average, from a European steam cracker, whereas the outer circle represents the distribution in terms of their value (in USD/t). The production cost allocated to each fraction are close to its weight share in the product mix.

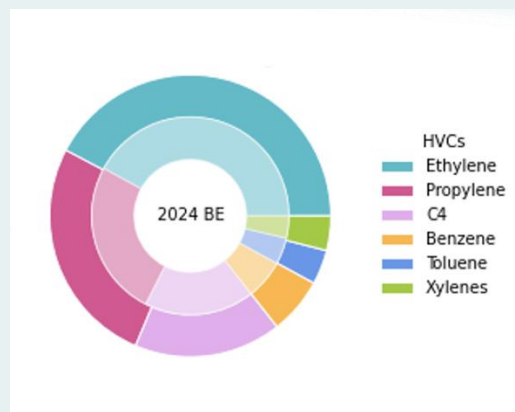

Figure 16: Value distribution of steam cracking products, based on average export prices from Belgium in 2024. Inner circle represents the weight distribution of the products while the outer circle depicts the corresponding value in USD/t.

The value distribution is shown for Belgian exports in 2024 and was evaluated based on the trade volumes (in USD and t) from UN Comtrade. The value distributions for the other regions were in line with this example. Figure depicts an annual average; actual temporary prices might vary.



2.3.1 Evolving industrial landscape in the TCR: plant closures and new projects

During the past five crisis years, the chemical industry was under significant pressure. In 2022-2025, a lot of companies in the TCR have announced **strategic reviews of their business**. This has already led, for example, to restructuring and the divestment of business units. In the TCR, there have been several announcements illustrating this trend, among them:

- Evonik has finished several restructuring measures selling their polyester business (Witten, NRW) and allocating polyolefins production to its C4 business (Marl, NRW) [51];
- BP is monitoring opportunities to sell the Ruhr Öl refinery site in Gelsenkirchen [52], as well as Shell is considering selling chemical assets in Europe [53] which may affect the TCR sites in Rotterdam-Moerdijk and Shell Energy and Chemichals Park Rheinland near Cologne;
- SABIC has announced its withdrawal from the European market, affecting polymer production facilities and steam crackers across the TCR: in Geleen (the Netherlands), Genk (Belgium) and Gelsenkirchen (NRW) [54].

Additional measures of this kind can be also expected in the near future, as some companies are still reviewing their strategic direction. An even more alarming trend, however, is the continuing series of **plant closure announcements** across the chemical sector since 2022. As shown in the map of announced plant closures in the TCR (Figure 17), the entire chemical value chain is affected, including, for example⁴:

- **Refineries:** cessation of crude oil distillation and fuel production at the Rheinland refinery (Shell) near Cologne in 2025. The refinery will be restructured for other products [55];
- **Steam crackers:** in total, three steam crackers will be closed until 2027 (see discussion below);
- **Other bulk chemicals:** stop of cumene production by Olin in Terneuzen announced in 2023 [56], production of titanium dioxide (TiO₂) Venator in Duisburg [57] in 2024 and by Tronox in Rotterdam-Botlek in 2025 [58]; cessation of chlorine and sodium hydroxide production by INEOS in Rheinberg [59], as well as phenol and acetone production by INEOS in Gladbeck [60] both announced in 2025;
- **Feedstocks for polymers and resins:** cessation of terephthalic acid production by INEOS in Geel in 2023 [61]; stop of styrene monomer production by Trinseo in Terneuzen in 2023 [62] and by LyondellBasell/Covestro in Rotterdam announced in 2025 [63]; cessation of caprolactam production by Fibrant in Geleen [64] as well as epichlorhydrin production by INEOS in Rheinberg [59] announced in 2025;
- **Polymers and resins:** stop of PET production by Indorama in Rotterdam in 2024 [65], cessation of PVC production by Vynova in Beek [66], and epoxy resin production by Westlake in Pernis [67];
- Multiple facilities for **mechanical recycling** of polymers: the closures are related to the overall crisis in the European plastic recycling industry, which experienced the largest ever capacity reduction (300 kt) in 2024. Half of this reduction originated from the Netherlands and the United Kingdom [68].

⁴ In view of the continuously changing situation of plant closures resulting from current dynamics, this list may not fully reflect the most up-to-date status. It provides examples of the changes occurring in the chemical sector. It is recommended that readers independently verify the latest developments.



Considering the total nameplate ethylene capacity of steam crackers in the EU in the end of 2024 (20.3 Mt) and the actual ethylene production of 11.6 Mt [26], the average European capacity utilization rate amounted to approximately 57 %. Taking into account the announced closures in 2025 (Italy: -970 kt; the Netherlands: -565 kt) and 2027 (Germany: -565 kt; Belgium: -550 kt), along with the commissioning of a new ethane cracker in Antwerp (+1,450 kt), the resulting capacity utilization, assuming unchanged production volumes, would rise to approximately 60 %, which remains well below optimal levels.

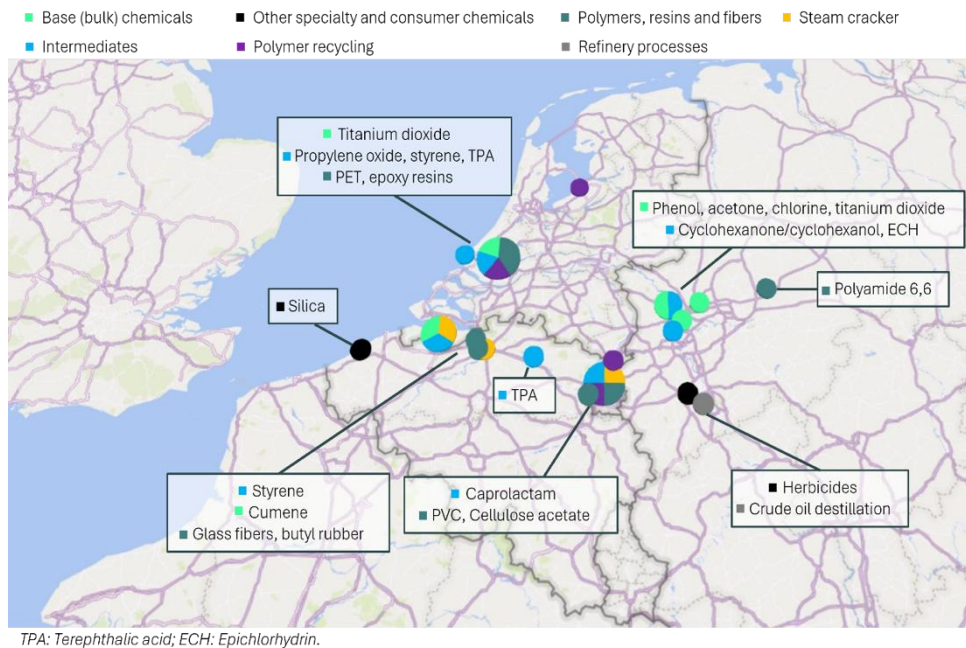

Figure 17. Plant closures in the TCR: ceased production in 2022-2025 and announced closures for 2026-2027. The size of the circles does not correlate with the nameplate capacity. State: January 2026, non-exhaustive list.

Within the steam cracker value chain, the closure of three steam crackers with a combined ethylene capacity of 1,665 kt per year has been announced in recent years – about 17 % of the TCR's total ethylene steam cracker capacity in 2021. The crackers in Terneuzen (Dow) [69] and Geleen (Sabic) [70], [71] (1,115 kt/a in total) have already been shut down, while the closure of the Antwerp cracker of TotalEnergies (550 kt/a) has been announced for 2027 [69].

Europe, like the rest of the world, has large overcapacities in terms of steam crackers, which leads to uneconomic capacity utilisation [40]. In light of the continuing energy crisis with increased feedstock costs, decreasing downstream production and growing competition with producers in lower-cost regions, the announced closures of steam crackers in the TCR hint at a market driven rationalisation [72].

The announced closures must be viewed in a broader, interconnected context rather than in isolation. The closure of a single company within a chemical cluster often affects both upstream and downstream partners. Especially existing and planned feedstock and energy supply systems may be affected. One example of the impact the weakening downstream demand can have is the Terneuzen site, where the closure of the steam cracker was announced following the shutdown of cumene and styrene plants [73]. Both cumene and styrene production units used cracker products (ethylene, propylene and benzene) as feedstocks. Another example is the closure of the TiO₂ (pigment) production in the Port of Rotterdam that has directly affected the company's chlorine suppliers [74]. Similarly, the closure of caprolactam production at the Chemelot site (Geleen, the Netherlands) is reducing the H₂ off-take from other



companies at the site thus affecting their businesses [64]. While these examples illustrate how plant closures can negatively affect both the upstream and downstream parts of the value chain, the extent of these impacts and the available mitigation options vary substantially depending on the specific process and site location. In this context, the transportability and economic feasibility of sourcing a commodity that is no longer produced within the chemical park play a particularly crucial role.

Other factors impacting the future of the steam cracker value chain in the region are **cancellations and the lack of new investment decisions for projects** aiming to reduce emissions and support utilisation of alternative feedstocks for polymer production. Vioneo, for example, has recently cancelled its planned methanol-to-olefins (MTO) plant in the Port of Antwerp-Bruges (300 kt polymers per year) and relocated the investment to China [75]. Several chemical recycling projects have also been abandoned, including Neste's planned pyrolysis facility in Vlissingen [76] and the Blue Cycle recycler in Heerenveen [77]. These cases illustrate the difficulty of retaining investments in more sustainable technologies in Europe in general. As the Vioneo case illustrates, globally active companies can shift investments to regions offering low-cost feedstocks, such as bio-methanol in this example. In addition, low-priced virgin plastics and limited market demand for sustainable products further undermine investments in new facilities in Europe [76].

At the same time, the investment decisions for several **new commercial-scale chemical plants** have been taken in 2018 and 2019, before the ongoing crisis. They have either begun operation in recent years (Figure 18) or are currently under construction, with commissioning announced for the upcoming period. Among these are two olefin production facilities, both of which are not the conventional naphtha-based steam crackers. The first is an ethane cracker (Project ONE, INEOS) with a nameplate capacity of 1,450 kt/a of ethylene, and the second is a PDH plant (PDH2, Borealis) that will add approx. 740 kt/a of propylene to the existing production capacity at the site. Both facilities are located in Flanders (Antwerp and Kallo). With these new olefin production facilities going online, even more closures of existing steam crackers might be possible. The plants are expected to use lighter feedstocks, such as ethane and propane, which are currently cheaper than naphtha – the main feedstock used by steam crackers in the TCR at present (see Chapter 2.1.2 *Current feedstocks*, p. 9).

There are also ongoing transformation projects in the refinery sector in the TCR. For example, Shell's Rheinland refinery is being converted away from fuel production and a base oil plant is being constructed, which is expected to be completed by 2028 [78]. Similarly, Neste plans to double the capacity of its Rotterdam biorefinery by 2027 (from 1.3 Mt to 2.7 Mt of renewable products per year) [79].

Alongside the closure of multiple mechanical recycling facilities and chemical recycling projects in the Netherlands discussed above, several chemical recycling plants for polymers have begun operation in recent years or are currently under construction within the TCR. It is worth noting that despite the trend, these projects remain at a small commercial scale: some of them can process 10-20 kt/a of polymer waste, other can operate at a higher scale producing up to 50 kt/a pyrolysis oil. For comparison, a conventional average European naphtha steam cracker with a nameplate capacity of 550 kt/a of ethylene would require approx. 1,700 kt of naphtha feedstock at a capacity utilisation rate of 90 %. This implies that substantial additional recycling capacity will be needed to achieve large-scale use of locally produced py-oil or py-naphtha as steam cracker feedstock. Some ongoing projects have already incorporated expansion options during the initial planning phase. However, the realisation of these options will depend on the results of the smaller plants, especially whether these projects prove their commercial feasibility.

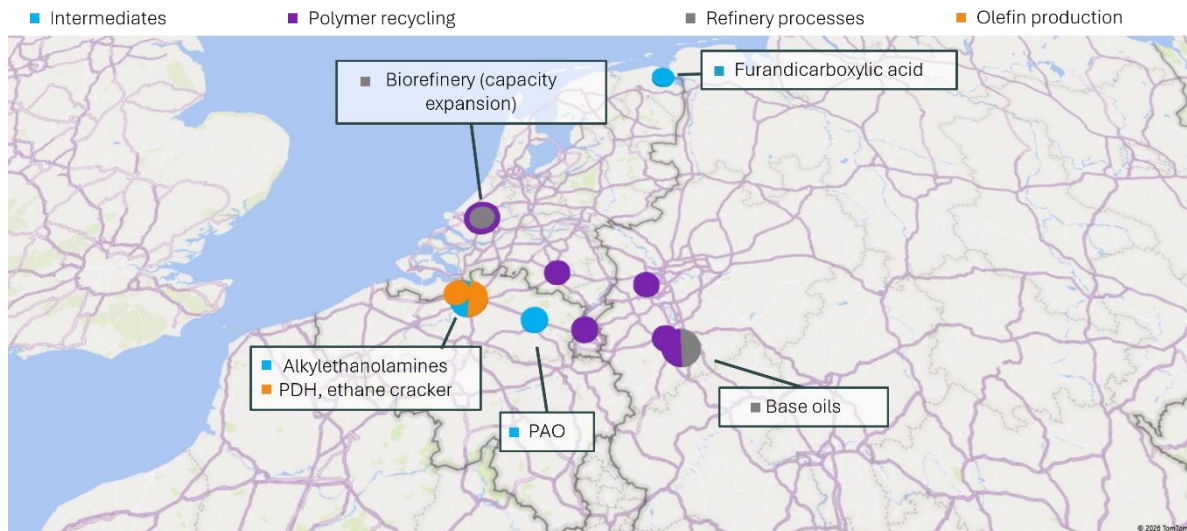

PDH: propane dehydrogenation; PAO: poly-alpha-olefins.

Figure 18. New commercial scale facilities (2022-2025) and those announced for commissioning in 2026-2028. Only projects with a nameplate capacity above 10 kt/a were considered. The size of the circles does not correlate with the nameplate capacity. State: January 2026, non-exhaustive list.

New investments, however, do not balance the announced capacity closures in Europe, with the TCR being no exception. The recent European Closures and Investment Radar report by Cefic and Roland Berger [19] highlights a growing imbalance between closures and investments, showing the largest negative net effect (investments minus closures) in Germany (-8.0 Mt) and the Netherlands (-6.9 Mt). Belgium remains the only country with a neutral balance (+0.1 Mt) in 2019, which is insufficient to counteract the threatening overall capacity loss for the chemical industry across the TCR.

2.4 Stakeholder perspectives on the current state of the TCR

KEY INSIGHTS

- The SWOT analysis captured the following perspectives from chemical companies in the TCR:
 - The TCR bears clear advantages for chemical production due to its location, infrastructure density and integration.
 - The higher costs compared to global competitors for energy and feedstock due to domestic policies and the dependence imports are considered the crucial weakness.
 - Increasing the resilience against dependencies on imports and external competition, through e. g. circular economy, is an important opportunity for the TCR.
 - The position on the value chain determines which factors are considered threatening (upstream: high energy and feedstock costs and limited availability of cost-competitive alternatives).

To gain a comprehensive and realistic understanding of the situation, and to ensure that industry perspectives and feedback were fully considered, we conducted a SWOT analysis with key stakeholders from the chemical sector to assess their view of the current state of the TCR. For detailed methodology see Chapter *SWOT Analysis*, Annex A, p. 7. During the workshop, 22 professionals from 18 companies located in the Netherlands, Flanders and North Rhine-Westphalia – from refineries to polymer- and specialty chemical producers – participated, as well as representatives from the chemical



associations and politics. From the evaluation of the bilateral interviews with the companies, which we held prior to the workshop, we could assign the current *Strengths*, *Weaknesses*, *Opportunities*, and *Threats* (SWOT factors) of the chemical industry in the TCR to three categories, which we refer to as *fields of action*:

- Security of supply (including both energy and fossil feedstock)
- Business development
- Alternative feedstocks

The SWOT (Strengths, Weaknesses, Opportunities, Threats) analysis is a method typically used for strategic planning and business analysis. It facilitates the identification of internal and external factors which may contribute to an organization's relative advantages or disadvantages. Through the correlation of internal vs. external factors, it enables the development of strategies to advance on specific topics. We utilized the SWOT approach at our first stakeholder workshop to capture the perspectives of the companies in the TCR on (i) the current state of the region and (ii) relevant future strategies and developments.

We conducted three individual SWOT analyses, each with a focus on one of the three fields of action, with the aim to obtain specific and structured insights into the generally broad range of topics. During the first part of the workshop, the stakeholders assessed the current state of the TCR regarding the given focal points, by defining the most impactful SWOT factors. This was done by an anonymous voting of predefined and factors, which were evaluated by all participants prior to the voting. The detailed results are given in Figure 19 - Figure 22.

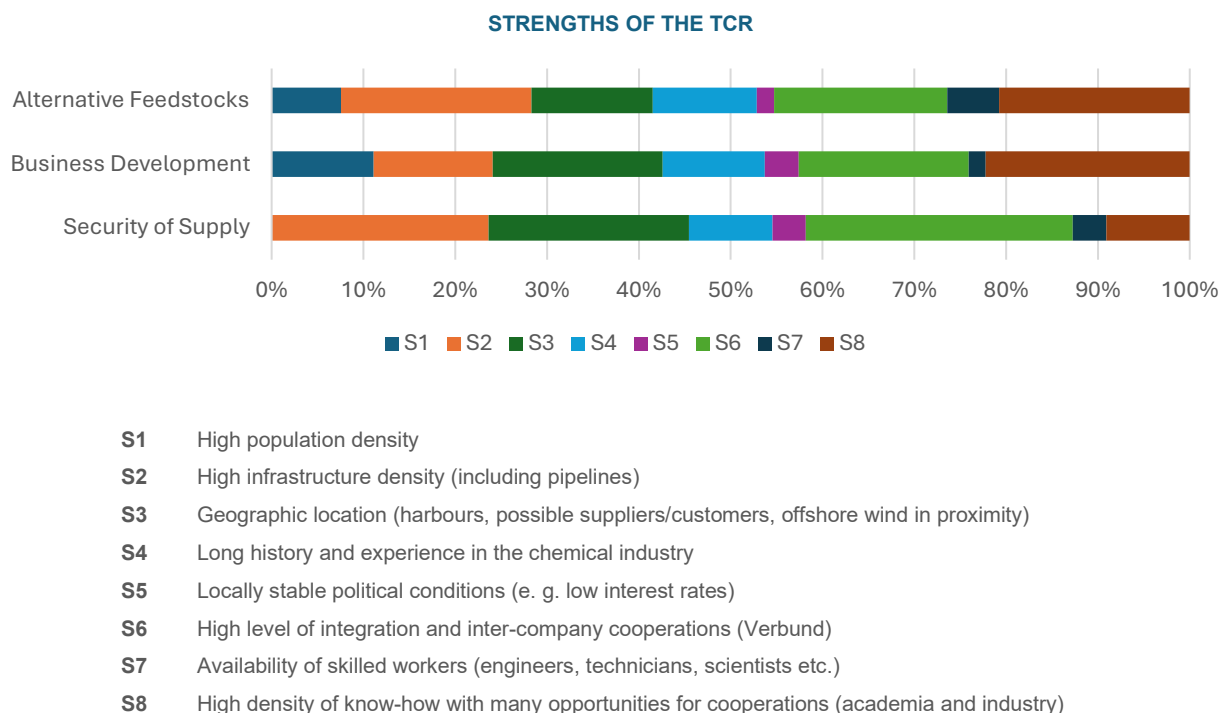
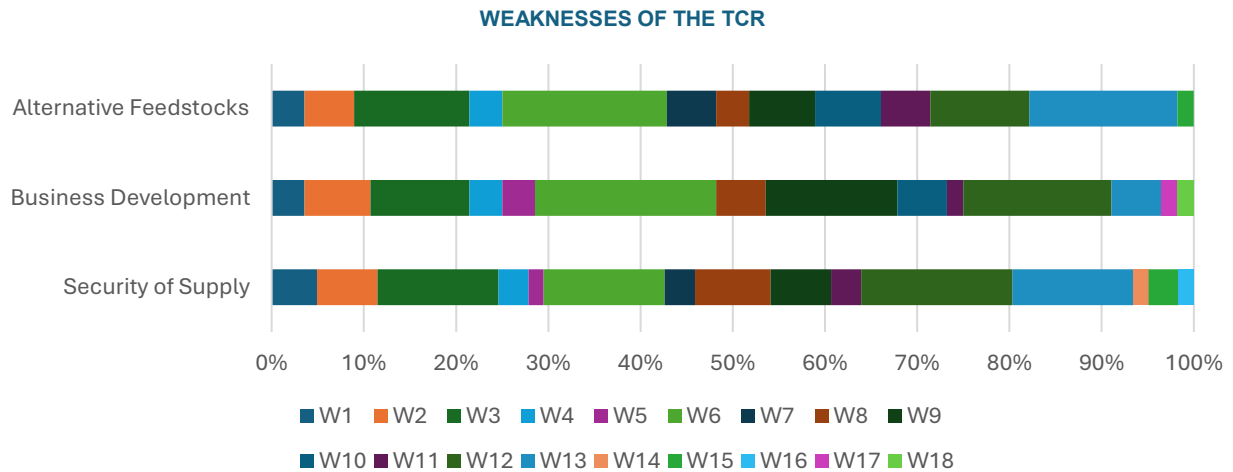

Figure 19. Stakeholder voting for the most important strengths of the TCR.

Across all three fields of action, similar selections of only four out of eleven possible strengths, each receiving a score of ≥ 10 out of 20 possible votes, indicate clear key advantages of the chemical industry



in the region. *High level of integration and inter-company cooperations (Verbund)* appears across all three fields of action, representing the most dominant strength and a defining characteristic of the industry itself. It is followed by *high infrastructure density, geographic location* and *high density of know-how with many opportunities for cooperations*. These factors partially overlap and collectively characterise the TCR, reflecting the regional advantages for chemical companies. Interestingly, the stakeholders from companies located upstream in the value chain showed a higher level of consensus regarding the key strengths than those positioned downstream. The latter group identified a broader range of factors, reflecting the greater diversity of requirements within their business activities.



- W1** High level of integration (strong dependence on specific suppliers and customers)
- W2** Different paces of refinery and chemical industry transformation
- W3** Dependence on energy and feedstock imports
- W4** High density of energy intense production (competition for (sustainable) energy/feedstock)
- W5** Lack of skilled workers (engineers, technicians, scientists etc.)
- W6** Challenges of transforming an optimised system (economically optimised for fossil feedstock)
- W7** Geographic location (risk of floodings/droughts, limited availability of biomass)
- W8** Infrastructure bottlenecks (e. g. bridges, rail capacities, canals)
- W9** Old production facilities that require modernisation
- W10** Lack of experience with alternative energy, feedstocks and processes
- W11** Lack of space
- W12** High energy costs
- W13** High feedstock costs
- W14** Competition/position of the other industries
- W15** Availability of natural resources
- W16** Economy of scale
- W17** Valley of death (gap between implementation of new technologies and profitability on industrial scale)
- W18** Lack of demand

Figure 20. Stakeholder voting for the most important weaknesses of the TCR.



The weaknesses present a similarly clear picture, with the *challenges of transforming an optimised system* playing an important role across all three fields of action. *High costs for energy and/or feedstock* are also recognised as a key weakness throughout the fields; however, companies upstream in the value chain viewed this issue more critically than those downstream. This may be due to downstream processes being generally less energy intensive and hence less affected unless alternative feedstocks, which the companies may be interested in utilising, come into play (further discussion on downstream/upstream parts of the value chain is in Chapter 2.1.1 *Analysed chemical value chains – Focus: steam cracker value chain*, p. 6). *Old production facilities that require modernisation* was identified as another obstacle to business development and supply security. Additionally, the *dependence on energy and feedstock imports* was considered as significant weakness.

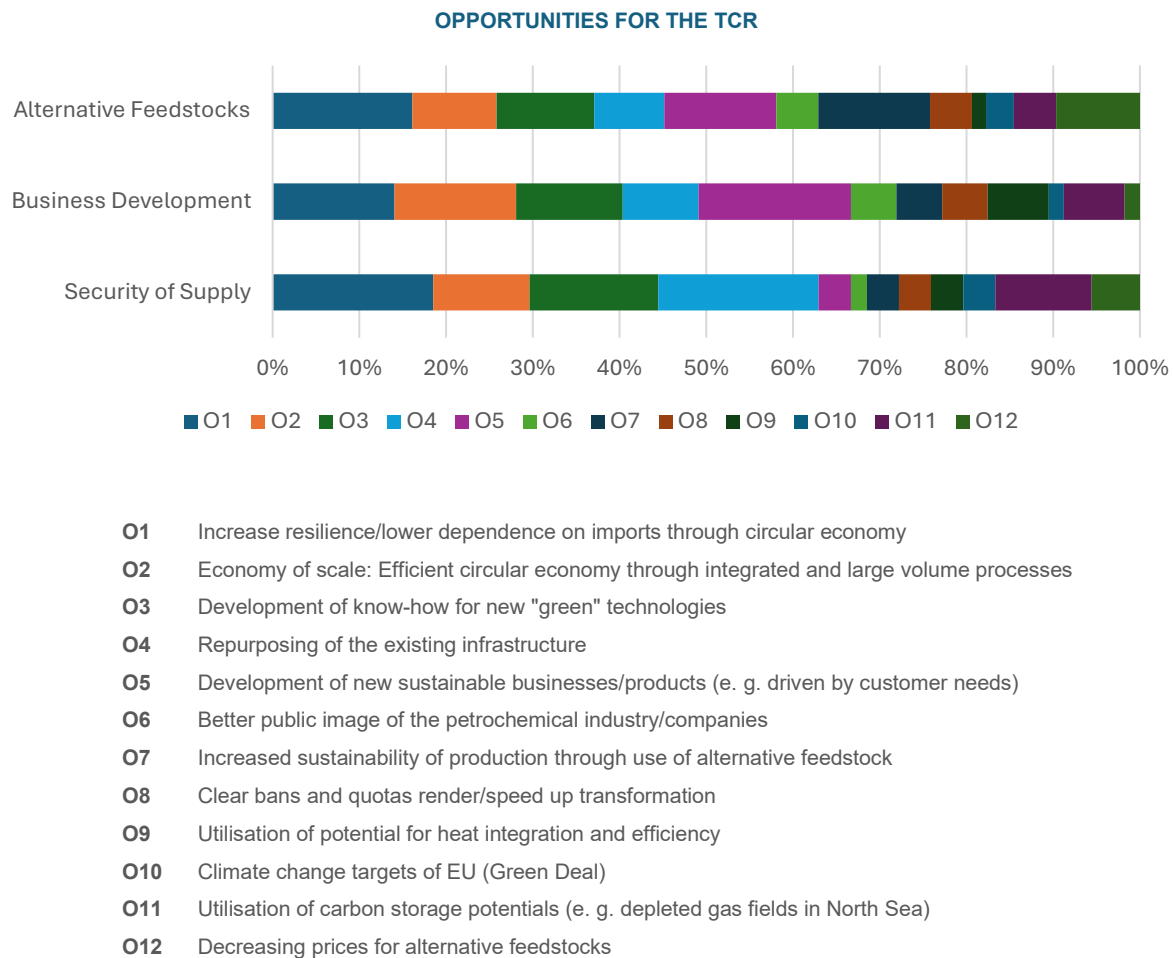
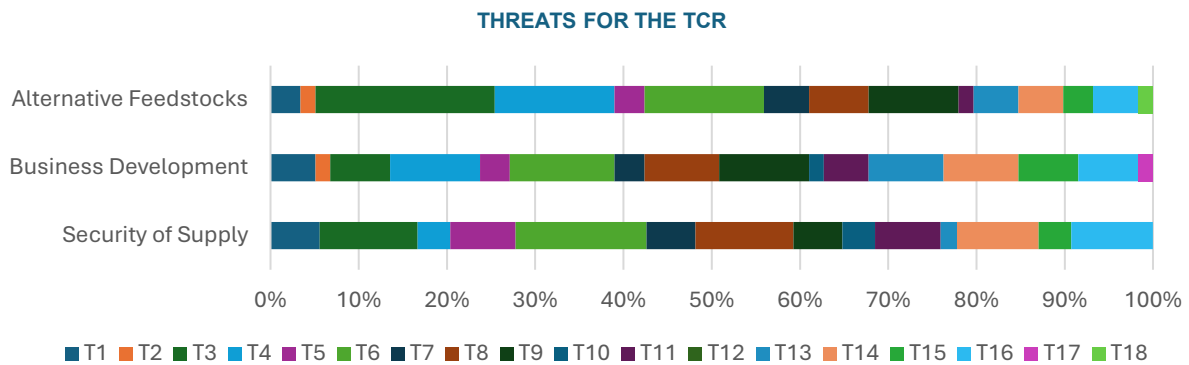

Figure 21. Stakeholder voting for the most important opportunities for the TCR.

A key opportunity, that was identified across all fields of action by stakeholders regardless of their position along the value chain, is to *increase resilience/lower dependence on imports through e. g. circular economy*. The *development of know-how for green technologies*, as well as *sustainable business cases and products* was also selected as an important opportunity in all three fields of action. Other important opportunities are the *repurposing of existing infrastructure* and *achieving sustainable production using alternative feedstocks*. The selection clearly highlights the industry's overall commitment to the EU's sustainability goals but also its fear over rising cost and the loss of competitiveness on a global market.



- T1 Insufficient infrastructure development for future demands
- T2 Loss of infrastructure
- T3 Insufficient availability of alternative feedstocks
- T4 Insufficient availability of sustainable energy and electricity
- T5 Supply gap due to faster phase-out of fossil resources than phase-in of alternatives
- T6 Rising energy prices
- T7 Rising prices/limited availability of fossil feedstocks
- T8 Volatile political decisions (e. g. disabling plans on longer time scales)
- T9 High transformation-related spendings (CAPEX, supplier financing, offtaker agreements etc.)
- T10 Bans of certain substances
- T11 Drop out of (local) suppliers and/or customers
- T12 Challenges caused by climate change (low water, floodings)
- T13 Lack of subsidies (e. g. for transformation investments)
- T14 Rising prices of alternative feedstocks making them uncompetitive
- T15 Different political development in the countries (e. g. hindering transformation decisions)
- T16 Long time scales and complicated approval procedures (e. g. permitting of new infrastructure)
- T17 Carbon leakage
- T18 Cheap imports, e. g. from Asia

Figure 22. Stakeholder voting for the most important opportunities for the TCR.

Regarding threats, stakeholders' views were less consistent. This, along with the long list of threats identified during the interviews, indicates a wide variety of challenges affecting different parts of the value chain. The common threats were (i) the *energy prices remaining high or even rising* (across all three fields of action) and (ii) the *limited availability of alternative feedstocks and energy* (specifically concerning *Alternative Feedstocks*). *Volatile policies* as well as *long and complicated permitting procedures* were also recognised. One threat emphasised primarily by refinery and cracker operators, is the *high transformation related costs* combined with the *absence of a suitable subsidy mechanism*, which is not surprising, considering their product cost containing the highest feedstock fraction and having tight margins (further discussion on downstream/upstream parts of the value chain is Chapter 2.1.1 *Analysed chemical value chains – Focus: steam cracker value chain*, p. 6). Overall, this outcome underscores the current inability of the industry, particularly of companies at the upstream part of the value chain, to take investment decisions in sustainable technologies, given the unfavourable CAPEX and OPEX perspectives.

3 FUTURE PERSPECTIVES

This chapter focuses on projecting future energy and selected feedstock costs and infrastructure needs for the TCR and Europe. First, different biomass based production pathways and biomass availability projections for the TCR are outlined in 3.1.1 below. Next, alternative carbon feedstock from recycled plastics pathways and their projected availability based on waste collection is estimated in 3.1.2. Further on it includes an overview of today's ethylene production processes and an assessment of future scenarios to estimate cost ranges for key energy carriers such as electricity, fossil fuels, CO₂, H₂, methanol and other biobased and e-fuels, considering different production and import pathways. An overview of the different 3C-VaCS scenarios and the olefin production routes that are included, is available in Table 9. A description of the different olefins production routes can be found in Table 10 and the scenario results are presented in Tables (Table 11, Table 12, Table 13, Table 14, Table 15, Table 16, Table 17, Table 18 and Table 19) in Annex B.

Regional cost comparisons help identify potential shifts in value chains and competitiveness challenges. Future electricity and feedstock demand for selected processes and production sites are analysed under various supply options, combined with geographically detailed estimates of future needs for electricity, H₂ and CO₂. Based on these insights, implications for energy infrastructure, primarily H₂ and CO₂ networks are explored. Finally, a cost comparison (3.5) is made with regions outside of Europe, in light of the relevant policies (Chapter 3.6).

3.1 Novel pathways to producing key chemicals

KEY INSIGHTS

- Biomass-derived olefin and aromatics production proceeds via methanol, ethanol, or bio-naphtha routes, with methanol pathways requiring high energy input, generating CO₂ during syngas conditioning, and depending on high-temperature fluidised-bed reactors and capital-intensive separations.
- Alternative biomass cracker-feed routes such as pyrolysis + hydrotreating and Fischer–Tropsch synthesis yield bio-naphtha but face technical barriers including high H₂ demand, catalyst instability, and overall energy intensity; only second-generation feedstocks (per RED II) are considered in the TCR.
- European biomass availability is projected to rise from 437,5 million dry tons (MDT) in 2020 to 525-800 MDT in 2030 and 875-1.338 MDT in 2050, with the study assuming that up to 30 % of total biomass could be allocated to the chemical/materials sector.
- The import of solid biomass from outside the EU is not considered due to its high energy penalties over long distance and strict RED II sustainability requirements.
- Plastic-to-chemicals pathways include physical recycling and chemical recycling (pyrolysis, gasification, depolymerisation), with pyrolysis yielding low naphtha fractions (16 %) and thus large feedstock needs; in the 3C-VaCS scenarios, pyrolysis is included with ≤ 10 % py-oil blending in existing crackers.
- There is a large potential in the TCR collect and sort plastics to increase its reuse both for mechanical and chemical recycling. This in combination with the availability of know-how, logistics and processes as described in Chapter 2.4. However today, exact plastic waste availability figures in the TCR are constrained by data inconsistencies, high export shares and undocumented or accumulated flows.



3.1.1 Biomass based pathways to produce olefins and aromatics

Biomass derived production routes for olefins and aromatics offer alternatives to fossil-based pathways by converting lignocellulosic resources or biogas into methanol, ethanol, or bio-naphtha, which can then be transformed into platform chemicals. Methanol pathways, including biomass gasification and biogas reforming, produce syngas intermediates that are catalytically upgraded, though they require substantial energy input and show significant CO₂ release inherent to syngas conditioning. Downstream methanol upgrading via MTO enables production of ethylene, propylene, BTX other aromatics. These processes rely on high-temperature fluidised bed reactors and complex separation systems with large associated investment costs.

Alternative cracker-feed routes such as fast pyrolysis with hydrotreating and biomass-based Fischer-Tropsch synthesis generate bio-naphtha suitable for steam cracking, although they face technical challenges including high H₂ demand, catalyst instability, and energy intensity. Both bio-methanol and bio-naphtha as alternative feedstock to produce olefins is being evaluated in this study. These pathways, along with other alternatives such as ethanol to olefins are described in greater detail in Annex F, page 1. However, the biomass based pathways included in the 3C-VaCS study are covering some, rather than all possible technologies out there.

The different types of **available biomass in the TCR** are sugar-based, oil-based, lignocellulosic and other organic wastes and residues. The potential availability of only second-generation options like lignocellulosic and other organic wastes and residues are considered for biobased production in this study due to concerns related to food security, competition for arable land, and ethical considerations. Thus, the focus is set on feedstock categories listed under the Renewable Energy Directive (RED II) as in Annex F. Biomass availability in the TCR

These second-generation feedstocks include:

- Lignocellulosic biomass, such as agricultural and forestry residues including straw, wood chips, and sawdust. These materials are widely available in Europe, particularly in countries with large forestry industries such as Sweden, Finland, and Germany.
- Other organic wastes and residue feedstocks (non-oil based), which include municipal solid waste and industrial residues.
- Other organic wastes and residue feedstocks (oil and fat based), which include used cooking oils, crude tall oil and tallow. In Europe, the collection and processing of used cooking oils have expanded, especially in countries such as the Netherlands and the UK, where waste-to-biofuel initiatives are well established.
- There are several studies in the literature which assess the biomass potential in Europe like the European commission [83], [84], [85], Oak Ridge National laboratory [86], bioenergy KDF [87] and Concawe study [88], [89]. The Concawe study was used in this study as it had a better disaggregated availability data for the TCR with different biomass types. The Concawe study [90] supported by Borzęcka et al. [91] projects an increase in total bioenergy potential from 175 Mio. t of Oil Equivalent (Mtoe) in 2020 to a range of 210 to 320 Mtoe by 2030 and 350 to 535 Mtoe by 2050 in Europe. In terms of biomass availability, this corresponds to 437.5 Million dry tons (MDT) in 2020, increasing to 525 to 800 MDT by 2030 and 875 to 1,338 MDT by 2050. By 2050, the study estimates that 360 Mtoe annually (900 MDT) will be required, with an additional 15 Mtoe per year expected to be imported. However, due to it's high energy penalties over long distance and strict RED II sustainability requirements, import of solid biomass from outside the EU are not considered in this study.



Three scenarios have been analysed in the Concawe study, 2030:

- Low biomass mobilisation (Scenario 1 - Low)
- Improved mobilisation in selected countries due to improvements in cropping and forest management practices (Scenario 2 - Medium)
- Enhanced availability through research and innovation (R&I) measures as well as improved mobilisation due to improvements in cropping and forest management practices (Scenario 3 - High)

From the three scenarios, an average of the Concawe scenarios 1 and 3 is taken, of which 20-30 % of the volume is assumed to become available in the chemical and materials industry, according to a study from the Nova-Institute [92]. The upper bound of 30 % is taken as the available biomass to calculate the maximum bio methanol or bio naphtha in this study as the goal of the project is to assess the maximum potential of alternative feedstocks, either domestically sourced or imported, to replace fossil based petrochemical production. Though the TCR and in extension the countries Belgium, Germany and the Netherlands have limited biomass resources on their territories to replace current fossil feedstock in the chemical industry, European biomass potential could complement this deficit.

3.1.2 Plastic waste based pathways to produce olefins and aromatics

Plastic waste can be converted into olefins and aromatics through physical recycling (mechanical and dissolution) or chemical recycling (depolymerisation, pyrolysis, and gasification). Mechanical recycling preserves polymer structure but suffers from contamination sensitivity and polymer degradation, limiting recyclability and making it unapplicable for food or medical grade polymers. Chemical recycling enables processing of mixed or contaminated plastics by converting them into monomers, pyrolysis oils, or syngas suitable for downstream petrochemical routes.

Pyrolysis followed by steam cracking of pyrolysis oil yields olefins and aromatics, though low naphtha yield (around 16 %) necessitates large waste input and possibly heavy-oil crackers.

Gasification produces syngas that can be catalytically upgraded to methanol and further converted to olefins (MTO) or aromatics (MTA), offering flexibility for mixed-plastic waste.

In this study, only pyrolysis of plastic waste process has been used in the scenarios, with a maximum of 10 % blending pyrolysis-oil (py-oil) in existing naphtha crackers.

Available plastic waste, as alternative cracker feedstock in the Netherlands, Germany and Belgium, is mapped in different waste categories and regional production potential. Data on plastic types, production, exports, and waste handling from basis years 2022-2023 sources were analysed. Plastics are classified into thermoplastics and thermosets, a distinction crucial for determining suitable chemical recycling technologies due to differing thermophysical properties. Following analysis provides a snapshot of plastic flows across key consumption sectors, including packaging, construction, electronics, household goods, agriculture, and other applications, with stock and unknown fractions represented in the Sankey diagrams below, Figure 23, Figure 24, Figure 25 as well as in Annex H. Plastic waste availability in the TCR. Like the biomass based alternatives, the plastic waste based pathways included in the 3C-VaCS study are covering some, rather than all possible technologies out there.

Plastic production, usage, export, and waste treatment data for the **Netherlands** were compiled from Conversio [93], Circular Plastics NL [94], and Statista sources covering 2022-2023 [95] (Figure 23). Unfortunately, the data sources use different basis years which introduce limitations that were not further analysed. The Netherlands produces 6.7 Mt of plastics, with 17 % from recycled sources, and

exports most of its production, reducing the potential for chemical recycling. Only 34 % of produced plastics are processed domestically, with packaging (41 %) and construction (26 %) as the main application sectors. Of the 1.95 Mt of plastic waste generated, 86 % is thermoplastic, and while 266 kt of pre-consumer waste is easily recycled, 1,103 kt of post-consumer waste is collected despite contamination challenges. PVC end-of-life treatment is poorly documented and classified as unknown. Overall waste handling results in 409 kt recycled, 583 kt incinerated, and ~550 kt exported or accumulated, with study uncertainties arising from inconsistent data sources and unanalysed discrepancies.

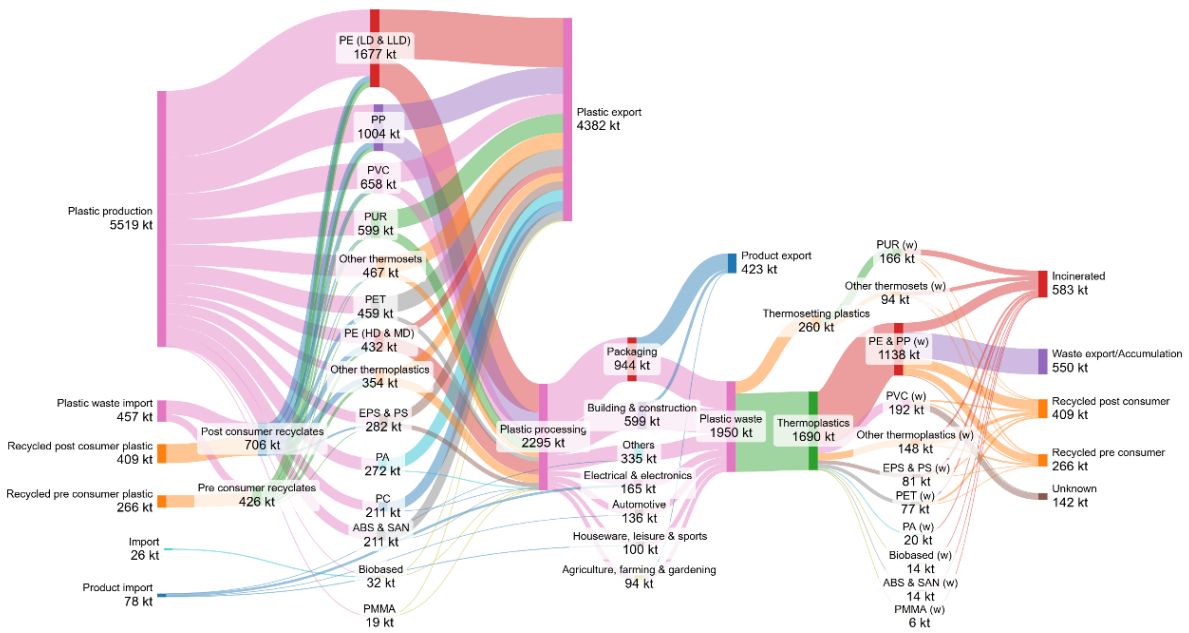

Figure 23. Plastics waste flow in the Netherlands in 2022. Own representation with data from [93], [94].

Plastic production, usage, export, and waste treatment data for **Germany** were compiled from Conversio (2022) [96] and Basel Action Network (2023) [97] (Figure 24), though differing basis years introduce limitations and unanalysed discrepancies. Germany produces 12.85 Mt of plastics, with 19 % from recycled sources, and uses most domestically, while main sectors include packaging (27 %), construction (21 %), automotive (9 %), and electrical & electronics (9 %). A large mismatch exists between production and collects waste, with 6.3 Mt collected but ~4.9 Mt remaining undocumented, accumulated, or embedded in exported products. Of the collected waste, 91 % is thermoplastics, with non-recycled thermosets assumed available for gasification and non-recycled thermoplastics (excluding PVC) assumed suitable for pyrolysis, while PVC end-of-life handling remains unclear. These assumptions, combined with data gaps and inconsistent reporting years, constrain the accuracy of estimating Germany's true chemical recycling potential.

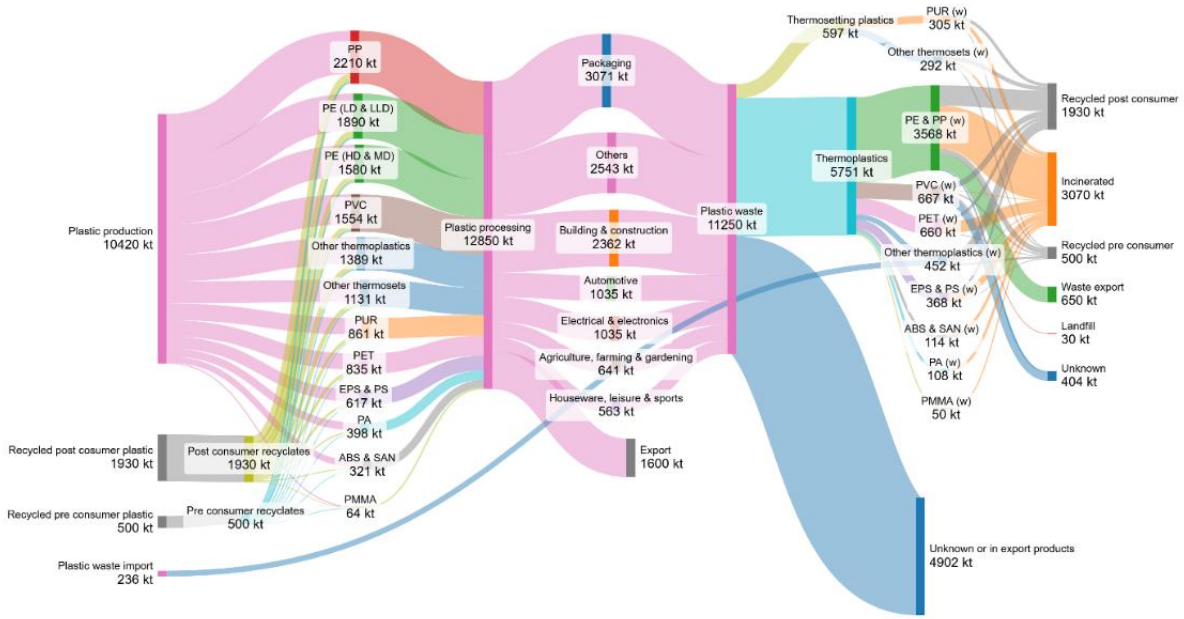

Figure 24. Plastic waste availability in Germany in 2023-2024. Own representation with data from [98].

Plastic production, plastic intermediate products (7,285 kt) and plastic end-products (2,380 kt), usage, export, and waste treatment data for **Belgium** (Figure 25) were compiled from Plastics Europe [99] and OVAM [100], though differences in basis years introduce limitations and unanalysed discrepancies. Belgium produces 7.3 Mt of plastics, with only 5 % from recycled sources, while domestic consumption is low (1.2 Mt) and most plastics or plastic products are exported, making recycling challenging. Major application sectors include packaging (28 %), construction (22 %), automotive (9 %), and electrical & electronics (9 %). Only 0.6 Mt of plastic waste is collected, of which 60 % is incinerated, 39 % recycled, and 2 % landfilled, while 270 kt is exported and 100-300 kt remains undocumented. The lack of detailed polymer-type data limits further analysis, and for estimation purposes the waste composition is assumed to resemble Germany's.

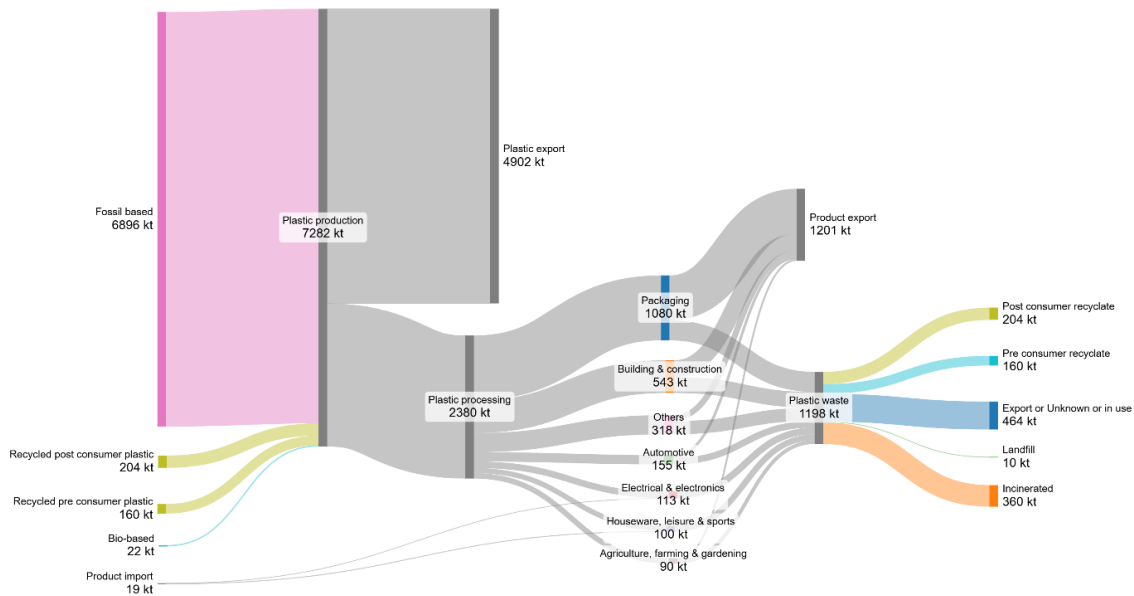

Figure 25. Plastic waste availability in Belgium in 2022-2023. Own representation with data from [99], [100].



3.2 Scenarios investigated in this study

To explore alternative emission reduction strategies for the chemical sector, multiple scenarios are defined, each providing a different outlook. The scenarios are composed of several existing and novel production processes, starting from a general objective of minimising the total system cost. It is important to note that model technology decisions are made through a cost minimisation which includes an assumed carbon tax of 185 EUR/tCO₂ in 2030 and 480 EUR/tCO₂ in 2050, based on climate neutrality by 2050 modeling for different sectors of the EU Commission [101]. Energy transport and storage costs are not included in the scenarios, as these aspects will be accounted for in the H₂ and CO₂ infrastructure analysis that follows.

Five 3C-VaCS scenarios:

- **Limited Biomass:** what if we could utilise all biogenic carbon resources, domestically available in each of the TCR countries? This local biomass, based on wood chips, is available at a cost of 107 EUR/t for chemical and refinery sectors to produce either bio naphtha, blended in existing naphtha crackers, with a maximum of 15 % based on available local biomass, or bio methanol with a maximum of 19 %. In addition, a maximum of 10 % of the current feedstock of existing naphtha crackers can be replaced by pyrolysis oil from plastic waste.
- **Maximum Biomass:** what if we could have access to all the EU imported sustainable biomass, besides the local biomass? The EU imported biomass in form of wood pellets is available at a higher cost at 230 EUR/t for chemical and refinery sectors. The higher cost reflects a scarcity effect of biomass in the EU, where biomass is traded at different prices.
- **Net Zero:** what if we would reduce direct CO₂ emissions of the chemical industry to near 100 %? In this scenario, biogenic emissions are subtracted from remaining fossil emissions.
- **RED III:** here we apply EU RED III policies for industry, only allowing industrial green H₂.
- **Global Efforts:** in this scenario we allow import of half fabricates such as green H₂, methanol and ammonia from outside the EU, at lower cost. The impact on industrial activity and infrastructure is analysed for each process.

OLEFIN PRODUCTION ROUTES

Based on olefins industrial blueprint used in the EU-AIDRES study [102] and our own analysis, following production routes have been used to calculate the cost of one ton ethylene in the TCR, both for existing and future technologies. Ethylene is one of the main outputs from a naphtha steamcracker, besides propylene, C₄ and BTX. The cost distribution across all steamcracker fractions are spread out somewhat similarly as shown in Chapter 2.3, making cost calculations for ethylene an adequate proxy for all outputs. Currencies and costs of energy and feedstock have been updated to 2025 figures.

The total ethylene production cost is minimised in all scenarios, meaning the lowest cost production route is selected and applied on all existing steam crackers and passed on to the H₂ and CO₂ infrastructure models, to calculate volumes of H₂ and CO₂ for each scenario. Carbon Dioxide Removal (CDR) are turned on, using the Emission Trading System (ETS) prices/CO₂ shadow cost as mentioned in Table 18, Annex B for biogenic CO₂ emissions which are captured and permanently stored. The effects of CDR are further highlighted in the H₂ and CO₂ infrastructure model results. Ethylene production routes are based on the EU-AIDRES energy intensive industrial data set, where industrial blueprints (models) have been developed, including process integration of heat and cold flows. Electricity prices have been grouped in three price ranges; realistic, optimistic and conservative, to allow for uncertainties in future electricity production costs, transmission and distribution investments and taxes & levies, typically for large industrial off takers.

An overview of the 3C-VaCS scenarios calculations and main assumptions for the olefin production routes are available in Annex B:

Table 9. Overview of olefins production routes per 3C-VaCS scenario.

Table 10. Description of olefin production routes used in the 3C-VaCS scenarios

Table 11. Cost and CO₂ related parameters for olefin production routes used in the 3C-VaCS scenarios

Table 12. Overview of bio-naphtha production costs for 2030 and 2050.

Table 13. Overview of imported bio-naphtha production costs for 2030 and 2050.

Table 14. Overview of local bio-methanol production cost (EUR/t) for 2030 and 2050.

Table 15. Overview of imported bio-methanol production cost (EUR/t) for 2030 and 2050.

Table 16. Calculation of the local bio-naphtha potential based on the biomass availability in Belgium, the Netherlands and Germany.

Table 17. Calculation of the local bio-methanol potential based on the biomass availability in Belgium, the Netherlands and Germany.

Table 18. Main input assumptions, pathways to produce ethylene.

Table 19. . Current and future electricity prices in the TCR.

1) Pyrolysis + Steam Cracking: Polyolefin-rich plastic waste is thermally decomposed into pyrolysis oil, which is hydrotreated and distilled to produce naphtha, diesel, and vacuum gas oil. Although roughly only 16 % of product is naphtha, all fractions can be steam-cracked to yield olefins. The route is technically feasible but requires very large waste volumes and heavy-oil cracker adaptation to be material-efficient. In this study, a maximum drop-in of pyrolysis oil of 10 % in existing naphtha crackers is assumed (Annex G. *Plastic waste based pathways for the production of olefins and aromatics*).

2) Biomass-derived Fischer–Tropsch (FT) synthesis converts gasified biomass into long-chain hydrocarbons using cobalt- or iron-based catalysts at 200-300 °C and 20-50 bar. FT liquids can be fractionated to yield bio-naphtha (C₅-C₁₀), a high-purity, sulphur-free stream suitable as a renewable drop-in feedstock for steam cracking to produce olefins and aromatics. Process conditions and catalyst design strongly influence light-hydrocarbon yields, and ongoing research targets optimisation for naphtha production rather than traditional middle distillates. The reference process converts 759 kt woody biomass into 53 kt naphtha alongside 111 kt other fractions (Annex E. *Biomass based pathways for the production of olefins & aromatics*).

Plastic waste can technically replace partly fossil feedstocks for producing base chemicals, but the scalability of these routes depends on feedstock purity, technology maturity, energy integration, and economic viability. Pyrolysis-based routes are closest to commercialisation but demand significant upgrades in cracker flexibility. By combining these production routes where e. g. bio-naphtha blend is allowed in existing oil-based naphtha crackers or by electrifying the heat of an existing naphtha cracker, a multitude of production routes and associated costs have been calculated. Also, different future H₂ and electricity price assumptions are leading to new outcomes. However, for the sake of comparing different results in this report, a selection of input assumptions has been made, reflecting the most important trends in production technology and impact of feedstock and energy costs.

3) Methanol to olefins



- Methanol is fed to the **methanol to olefin (MTO)** fluidised bed reactor operating at 30 bar and 450 °C. The MTO process produces ethylene and propylene along with other by-products (like methane, ethane, propane, C4's, benzene).
- **Methanol from lignocellulosic biomass gasification** is produced via pretreatment, oxygen-blown gasification at 850 °C, and catalytic syngas conversion at 300 °C and 80 bar. The process has high electricity and cooling demand due to air separation and syngas compression. Around 50 % of the biomass becomes methanol, while the remaining carbon is emitted as biogenic CO₂ to achieve the required H₂/CO ratio (*Annex E. Biomass based pathways for the production of olefins & aromatics*).

A description of other novel routes to produce olefins and aromatics from plastic waste, such as dehydrogenation of ethanol to ethylene and gasification of plastic waste to syngas-methanol can be found in Annex G. Besides production of olefins, there are many chemicals being produced in the TCR for which electrification production routes exist, be it with additional investments for high temperature heat parts. In the AIDRES study [104], E.g. for the production of polyethylene (PE): energy transition pathways shift from natural gas to electricity or green hydrogen, cutting direct emissions to near zero. Having access to low cost electricity becomes a key energy vector, indirectly determining total emissions via grid intensity. Whereas for producing ethyl acetate, production is far more energy-intensive than PE, with high natural gas use in conventional routes but strong emission reductions (up to 96-100%) when shifting to electricity pathways. Electricity plays an even larger role here, driving both higher energy consumption and the decarbonisation potential, making grid carbon intensity critical.

3.3 Ethylene production cost analysis 2030-2050

KEY INSIGHTS

- Blended bio-naphtha ethylene production remains one of the most expensive pathways (2,664 EUR/t Ethylene in 2030), by 2030 driven by costly EU-imported bio-naphtha and rising biomass prices, whereas ethane cracking with CCS is the lowest-cost option (974 EUR/t Ethylene).
- Even with CDR credits valued at the EU ETS carbon price, both MTO and bio-naphtha routes cannot fully offset their higher feedstock and conversion costs by 2030, making them less competitive than fossil or CCS-integrated pathways.
- Between 2030 and 2050, under given CO₂ shadow prices (up to 480 EUR/t CO₂), several alternative routes, including bio-naphtha, py-oil blends, and imported bio-methanol, become cheaper than fossil naphtha cracking (985 EUR/t), when taking the assumption that carbon dioxide removal can be accounted for as a revenue stream.
- Carbon pricing strongly reshapes relative economics: ethane cracking with CCS reaches fossil parity at only 70 EUR/tCO₂, while blended bio-naphtha, py-oil, and other CCS pathways become competitive at an ETS price of 220-340 EUR/tCO₂; biogenic MTO requires an ETS price of 340 EUR/tCO₂ for cost parity.



Ethylene production cost results 2030

In 2025, naphtha based ethylene in the EU is produced at around 850 EUR/t production cost, as compared with other regions in Chapter 2.3 *Competitiveness of current value chains*, p. 26.

By 2030, and under the assumptions outlined in Tables (Table 11, Table 12, Table 13, Table 14, Table 15, Table 16, Table 17, and Table 19 in Annex B), ethylene production via a blended bio-naphtha route is projected to reach ethylene costs of 2,664 EUR/t, placing it among the more costly options (

Figure 26). This pathway assumes the use of 15 % domestically produced bio-naphtha at 1.364 EUR/t and 85 % EU-imported bio-naphtha at 1,971 EUR/t. The elevated cost of imported bio-naphtha is primarily driven by higher biomass feedstock prices (230 EUR/t) resulting from increased market demand, compared with 107 EUR/t for domestic biomass. Ethane steam cracking combined with carbon capture represents the lowest-cost ethylene production route in 2030 at 974 EUR/t ethylene, marginally below the cost of the 2030 fossil naphtha-to-olefins reference pathway and above today's (2025) fossil based naphtha production cost of 850 EUR/t ethylene. Alternative naphtha feed-in routes, such as bio-naphtha or plastic-waste-derived pyrolysis oil – when blended into existing crackers and paired with carbon capture, exhibit higher production costs. These cost increases stem from the price premium of bio-naphtha and from limitations associated with the allowable blend ratios and technical constraints of introducing pyrolysis oil into conventional naphtha crackers. A similar pattern is observed for the (bio)methanol-to-olefins route, where the availability and price of low-cost biomass strongly influence bio-methanol production costs. Although both bio-naphtha and bio-methanol pathways can generate CDR credits, valued at the same rate as CO₂ emissions under the EU ETS, these credits are insufficient to offset their inherent cost disadvantages relative to fossil-based routes. Finally, electrification of process heat in existing naphtha crackers, replacing methane and off-gas combustion (the primary sources of direct CO₂ emissions), results in an ethylene production cost slightly above 2,000 EUR/t.

Table 2. Olefins productions results per scenario with CDR on. Upper values=2030, lower values=2050.

#	SCENARIO	LIMITED BIOMASS	MAXIMUM BIOMASS	NET ZERO	RED III	GLOBAL EFFORT
	Olefin production route in 2030/2050 (cost per olefines, scenario dependent see Table 11)					
	Total cost-optimised H₂ demand in BE-NL-DE for 6 AIDRES sectors, optimistic average H ₂ prices of 3,9 EUR/t in 2050 (Table 18). (TWh/year)	0 0	0 0	0 1,4	0 27,5	0 0
	Total cost-optimised CO₂ capture potential (biogenic and fossil) across 6 AIDRES sectors in the TCR in 2050. (Mt/year)	70,5	81,5	37,6	70,5	16,6
	Fossil naphtha (Mt/year)	27,6 20,7	27,6 0	20,7 20,7	27,6 20,7	0 0
	Ethane (TWh/year)	31,4 31,4	31,4 31,4	31,4 31,4	31,4 31,4	31,4 31,4
	Natural gas (TWh/year)	5,8 20,6	5,8 5,8	20,6 5,8	5,8 5,8	5,8 20,6
	Py-Oil (Mt/year)	0 2,7	0 0	2,7 2,7	0 2,7	0 0
	Biomethanol (Mt/year)	0 0	0 49,4	0 0	0 0	49,4 49,4
	Bionaphtha (Mt/year)	0 4,1	0 0	4,1 4,1	0 4,1	0 0
	Electricity (TWh/year)	6,7 15,6	6,7 5	15,6 15,6	6,7 15,6	5 5
1	Methanol to olefines using 100 % EU imported bio-methanol + carbon capture.					X
2	e-Methanol (based on co-electrolysis) to olefins.	X	X		X	X
3	e-Methanol (based on co-electrolysis) to olefins + carbon capture.	X	X		X	X
4	Naphtha cracker using 15 % local bio-naphtha and 85 % EU imported bio-naphtha.		X			X
5	Naphtha cracker using 15 % local bio-naphtha and 85 % EU imported bio-naphtha + carbon capture.		X			X
6	Naphtha cracker using 15 % local bio-naphtha and 85 % EU imported bio-naphtha + electrification of heat.		X			X
7	Methanol to olefines using 19 % local bio-methanol and 81 % EU imported bio-methanol.	X	X			X

8	Methanol to olefines using 19 % local bio-methanol and 81 % EU imported bio-methanol + carbon capture.	X	X			X
9	Naphtha cracker using 75 % oil based naphtha, 15 % local bio-naphtha and 10 % py-oil.	X			X	
10	Naphtha cracker using 75 % oil based naphtha, 15 % local bio-naphtha and 10 % py-oil + carbon capture.	X		X	X	
11	Naphtha cracker using 75 % oil based naphtha, 15 % local bio-naphtha and 10 % py-oil + electrification of heat.	X		X	X	
12	81 % imported e-methanol to olefins with 19 % local bio-methanol.	X	X		X	X
13	81 % imported e-methanol to olefins with 19 % local bio-methanol + carbon capture.	X	X	X	X	X
14	Naphtha cracker using 100 % oil based naphtha.	X	X		X	
15	Naphtha cracker using 100 % oil based naphtha + carbon capture.	X	X		X	
16	Naphtha cracker using 100 % fossil based naphtha + electrification of heat.	X	X		X	X
17	Methanol to olefins.					X
18	Methanol to olefins + carbon capture.					X
19	Ethane cracker with H2 and CH4 used for heat + carbon capture.	X	X	X	X	X

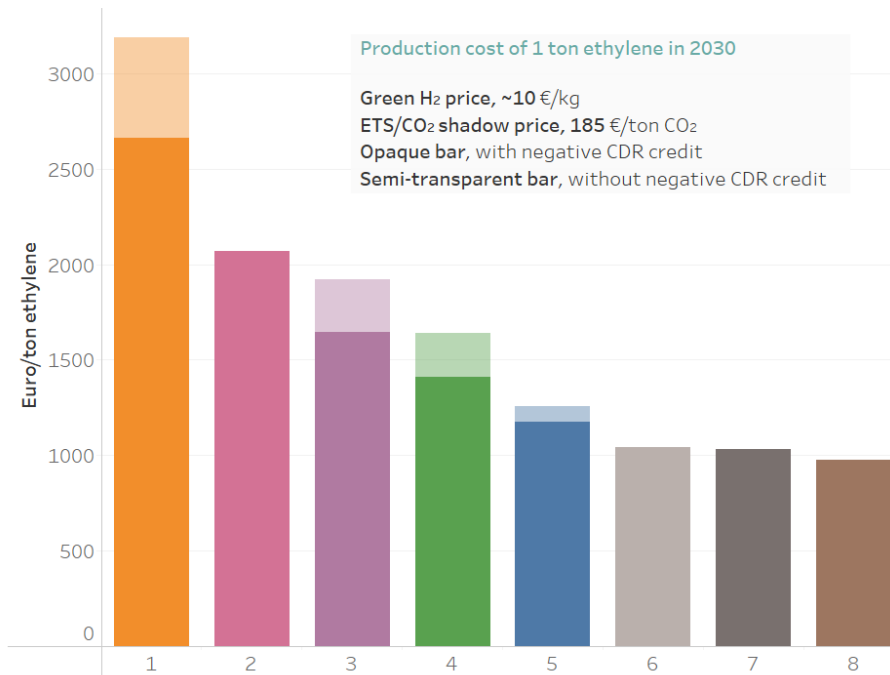

Figure 26. Ethylene production routes and cost in TCR by 2030. Own modelling work, based on [102].

Ethylene production route description

- 1** Naphtha cracker using 15 % local bio-naphtha and 85 % imported EU bio-naphtha + carbon capture
- 2** Naphtha cracker using 100 % fossil based naphtha + electrification of heat
- 3** Methanol to olefins using 100 % imported EU bio-methanol + carbon capture
- 4** Methanol to olefins using 19 % local bio-methanol and 81 % imported EU bio-methanol + carbon capture
- 5** Naphtha cracker using 75 % oil based naphtha, 15 % local bio-naphtha and 10 % py-oil + carbon capture
- 6** Naphtha cracker using 100 % oil based naphtha + carbon capture
- 7** Naphtha cracker using 100 % oil based naphtha (reference route)
- 8** Ethane cracker with H₂ and CH₄ used for heat + carbon capture

Ethylene production cost results 2050

In the **2050** outlook, several notable shifts in ethylene production costs emerge. Multiple alternative pathways are projected to achieve lower production costs than the fossil naphtha reference route (Figure 27). These include bio-naphtha and pyrolysis oil blend-in feedstocks combined with carbon capture, yielding costs of approx. 985 EUR/t ethylene, as well as the MTO route using 19 % locally produced –based on the maximum available biomass in the Netherlands, Belgium and Germany, as described in Chapter 3.1.1, and 81 % EU-imported bio-methanol, which remains slightly more expensive but still competitive. The primary driver behind these cost reductions is the negative CDR credit associated with capturing and permanently storing biogenic CO₂ emissions. Ethylene production based entirely on EU-imported bio-methanol also results in lower costs than the fossil benchmark. The future adoption of bio-methanol may additionally be supported by its potential use as a marine fuel, which could stimulate market expansion and investment in methanol transport and handling infrastructure. However, long-term biomass prices and the availability of sustainable biomass for chemical production remain subject to significant uncertainty. In contrast, electrification of heat supply in naphtha steam crackers is projected to be the most expensive production route under assumed electricity prices of approx. 100 EUR/MWh (including generation costs, grid tariffs, and taxes).

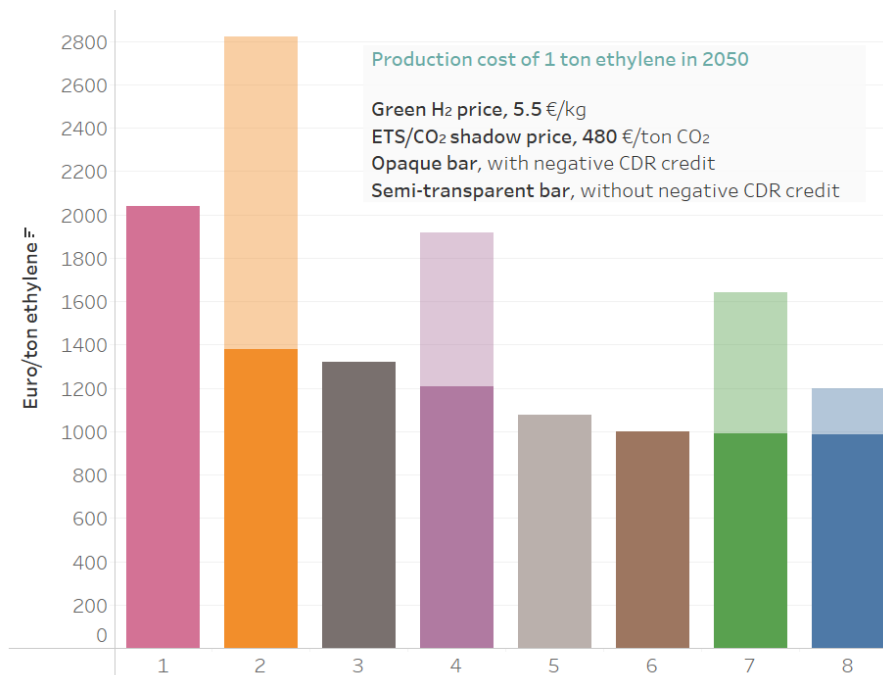

Figure 27. Ethylene production routes and cost in TCR by 2050. Own modelling work, based on [102].

Ethylene production route description

- 1 Naphtha cracker using 100 % fossil based naphtha + electrification of heat
- 2 Naphtha cracker using 15 % local bio-naphtha and 85 % EU imported bio-naphtha + carbon capture
- 3 Naphtha cracker using 100 % oil based naphtha (reference route)
- 4 Methanol to olefins using 100 % EU imported bio-methanol + carbon capture
- 5 Naphtha cracker using 100 % oil based naphtha + carbon capture
- 6 Ethane cracker with H₂ and CH₄ used for heat + carbon capture
- 7 Methanol to olefins using 19 % local bio-methanol and 81 % EU imported bio-methanol + carbon capture
- 8 Naphtha cracker using 75 % oil based naphtha, 15 % local bio-naphtha and 10 % py-oil + carbon capture

ETS/CO₂ shadow price evaluation across ethylene production routes in 2050

Forecasting a future EU ETS price is inherently uncertain, particularly given the long-term horizon to 2050 and the expectation, under current Green Deal targets, that industrial emissions will need to fall by around 95 %. Nevertheless, developing a range of ETS or CO₂ shadow price scenarios remains essential for exploring plausible technology shifts, feedstock transitions and investment decisions. In this analysis, the CO₂ shadow price is defined such that emitters of fossil-based CO₂ pay 480 EUR/tCO₂, while captured and geologically stored biogenic CO₂ receives an equivalent credit, allowing a balanced comparison of fossil and biogenic value chains. As shown in , introducing such a carbon price signal substantially alters the relative competitiveness of ethylene production routes. Several pathways, including fossil-based routes with partial blending of bio-naphtha or pyrolysis oil and equipped with CCS, become cost competitive with the current TCR fossil-based naphtha benchmark when the carbon price reaches 220 EUR/tCO₂ in the period leading up to 2050. Ethane cracking, using hydrogen rich off-gas for fuel and capturing and storing combustion CO₂ emissions, becomes cost-equal with the reference production route at a much lower CO₂ price of 70 EUR/tCO₂. More advanced

configurations, such as plastic-waste-based pyrolysis oil combined with CCS, also converge towards or below the cost of classical steam cracking as carbon prices rise toward 482 EUR/tCO₂, as seen in.

Biogenic MTO, where renewable methanol is catalytically converted into ethylene and propylene, requires a CO₂ price of roughly 340 EUR/tCO₂ reach parity with naphtha cracking. This underscores that while MTO offers long-term defossilisation potential, its cost competitiveness is highly sensitive to both carbon pricing and biomass feedstock availability. Carbon pricing, whether market based or applied as a CO₂ shadow price, plays an important role in shifting the economic balance among competing ethylene production pathways and can materially influence the direction of defossilisation.

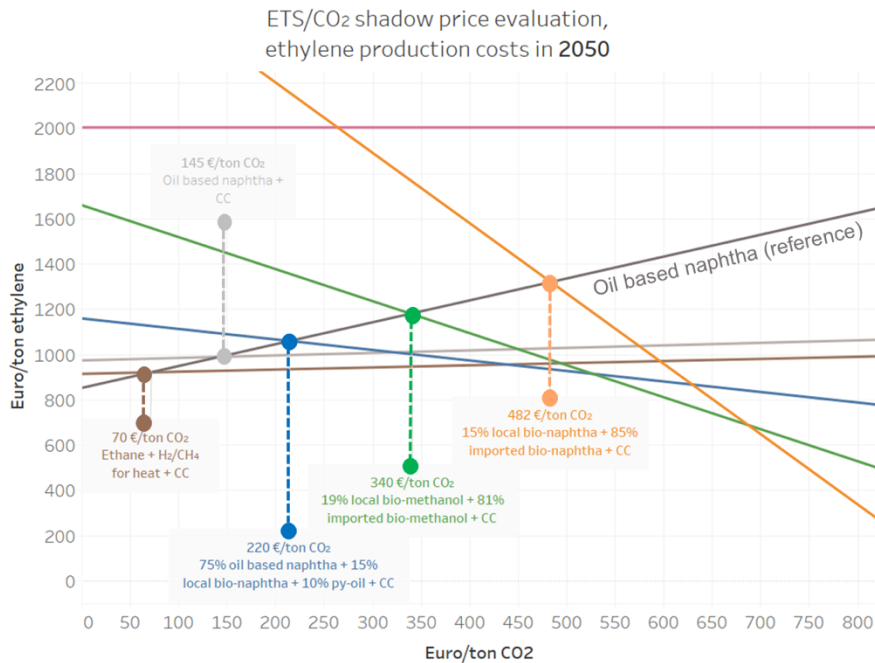

Figure 28. ETS/CO₂ shadow price evaluation of ethylene production cost in 2050. Own model results based on [104].

EU imported bio-naphtha price evaluation, ethylene production routes in 2050

Bio-naphtha can be co-cracked in conventional naphtha steam crackers with minimal or no modification, leveraging the extensive existing infrastructure of large-scale crackers. Bio-naphtha can also be mixed in combination with plastic waste based py-oil. This production route is shown in Figure 28 at 602 EUR/t local bio-naphtha, including CDR. In contrast, bio-methanol requires conversion via MTO, which requires more conversion steps, making it more capital-intensive. Bio-naphtha routes are more aligned with refinery technologies and have higher TRLs. Ethylene and propylene yields are also typically higher with cracking bio naphtha in addition to valuable aromatics, whereas MTO can achieve higher propylene and larger C₄ fractions, but no aromatics are obtained. Bio-naphtha production cost is estimated between 1,364 EUR/t and 1,971 EUR/t in 2030 and 602 EUR/t and 1,390 EUR/t in 2050, depending on the cost of biomass and CO₂ shadow price as in Table 18, including CDR, making it cost competitive only towards 2050.

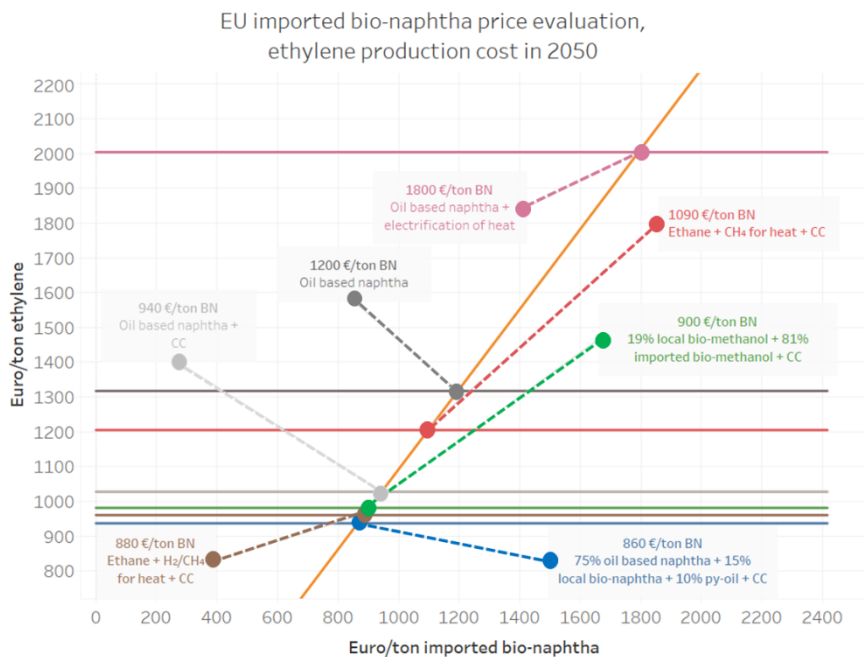

Figure 28. Bio-naphtha price evaluation of ethylene production cost in 2050. Own model results based on [102] and Table 12.

3.4 Infrastructure analysis for H₂ and CO₂ pipelines

KEY INSIGHTS

- Blue H₂ and CCS-integrated retrofits remain more economical than most green H₂ supply routes, as electricity cost dominates the levelised cost of hydrogen (60-70 %). The study results for the TCR show that green H₂ is less competitive, only becoming a prominent option under conditions where CCS and biomass are restricted or unavailable. The use of hydrogen is primarily as a feedstock rather than an energy carrier.
- All scenarios feature a cross-sectoral and cross-border CO₂ network as a cost effective solution, not only on a short term but also on a long term.
- Infrastructure planning must prioritise coordinated H₂-CO₂ network development, with pipeline repurposing preferred over new-build options to limit system costs and avoid stranded assets.
- Carbon capture dominance across industries and policy scenarios highlights the need for forward-looking planning. Cross-border coordination between carbon network operators (CNOs) in the TCR should allow for timely and efficient deployment of the CO₂ value chain.
- More studies and inquiries are needed to determine the possible suppliers (and offtakers) to correctly determine the routing and the dimensioning of hydrogen and CO₂ networks, minimising the risk of underutilisation, especially of the H₂ network.
- Recognising bio-CCS in the EU ETS as carbon dioxide removal significantly increases capture volumes and biomass use but also comes with potential implications for sustainable biomass cycles and investments in CO₂ transport and storage capacities.

3.4.1 Hydrogen infrastructure

Hydrogen modelling approach

Future industrial demand for H₂ and its geographical distribution remains highly uncertain, yet it is crucial for designing and sizing Europe's future H₂ infrastructure, especially in industry-dense regions. Industrial uptake will depend on cost competitiveness of H₂ relative to alternatives such as electrification, biofuels, CCS/CCU, or continued fossil-based production combined with higher CO₂ costs under the EU ETS. Ideally, such choices would be modelled endogenously but integrating detailed industrial transitions with the spatial and temporal resolution required for infrastructure analysis creates significant computational challenges. As a result, most national and EU models rely on exogenous H₂ demand estimates for likely adopter, e. g. ammonia, chemicals, primary steel, and refineries, which are then regionalised based on emissions or production capacity. Refinery light liquid fuel output is assumed to reduce with roughly 70 % by 2030, in line with Concauwe report [103]. To overcome these limitations, we developed a workflow that links the AIDRES industrial dataset [104] with a dedicated H₂ infrastructure model, allowing the identification of optimal technology pathways under different H₂ price scenarios.

The workflow consists of three key steps:

- **Scenario-Specific Demand Estimation for Each Industrial Site:** This step, implemented using the 3C-VaCS assessment tool, is described in Annex B.
- **Identification of Industrial Clusters as Potential H₂ Demand Hubs:** These clusters of the TCR (including six AIDRES industrial sectors, Annex B), which serve as focal points for regional demand allocation are further elaborated in Annex C. *H₂ infrastructure model*
- *Industrial Clustering.*
- **Scenario-Specific H₂ Infrastructure Optimisation:** This step is detailed in the subsequent sections, focusing on the development of optimised H₂ infrastructure tailored to scenario-driven demand patterns.

Estimating industrial H₂ demand within the 3C-VaCS study and designing an optimal H₂ infrastructure depend on the underlying low-carbon H₂ supply in the TCR. To capture this, the study applies five supply scenarios, each generating H₂ price estimates together with other energy and feedstock prices. This enables the model to determine optimal production pathways for each industrial product under different H₂ supply conditions.

Hydrogen supply scenarios

1. **Inland Blue H₂:** Blue H₂ produced onsite SMR/ATR units equipped with carbon capture.
2. **Green H₂ Import:** Pipeline import of green H₂ produced in renewable-rich regions (e. g., Spain) using dedicated renewable generation; levelised cost of hydrogen (LCOH) used as the import price, with Blaregnies-Mons⁵ as the feed-in point.
3. **Offshore Green H₂:** Green H₂ produced on offshore platforms integrating wind turbines and electrolysis, transported to shore via subsea H₂ pipelines using TYNDP2024⁶ offshore hub locations.

⁵ Belgian town located at the border to France.

⁶ Ten-Year Network Development Plan of 2024.

4. **Decentral Inland Green H₂:** Green H₂ from inland electrolysis located near industrial sites, powered by newly installed local solar PV and/or onshore wind in accordance with RED III additionality rules.
5. **Imported H₂ Derivatives:** Overseas import of H₂ carriers (e. g., ammonia) to ports, followed by dehydrogenation at terminal locations.

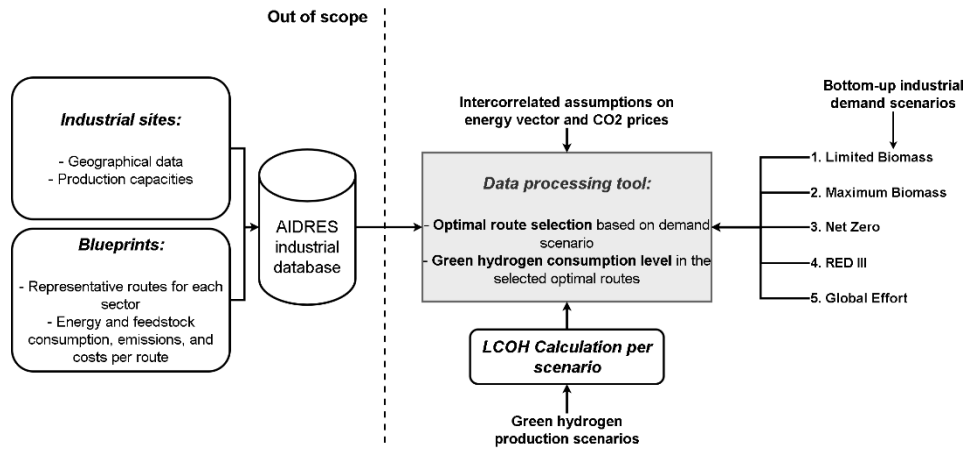

Figure 29. Inputs to the H₂ infrastructure model.

Hydrogen infrastructure cost optimisation

In this study, we employ the integrated version of the Hypatia modelling framework, to optimise the investment and operation of green H₂ infrastructure in the TCR. The model minimises the total discounted system cost over time, while satisfying a range of operational constraints, such as storage arbitrage and hourly renewable electricity availability based on technology-specific capacity factors and investment constraints, such as the maximum technically feasible capacity of centralised H₂ storage units (e. g., salt caverns) within each region. The system to be optimised encompasses both the capacity and generation of the technologies across the considered green H₂ supply chain, including dedicated renewable electricity technologies to electrolysis, H₂ storage and transport infrastructure (see Figure 30).

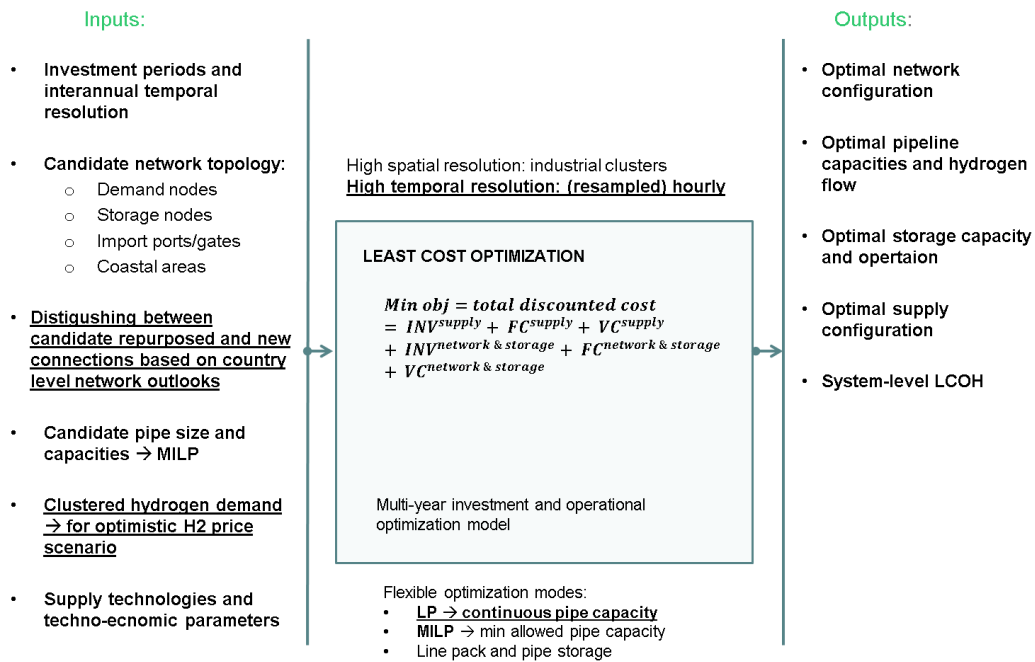

Figure 30. An overview of the inputs and outputs of the H₂ infrastructure optimisation model. Own work.

While the full mathematical formulation is detailed in Annex C. *H₂ infrastructure model*, key modifications in this study include a broader geographical scope and the adoption of a linear approach that models pipeline infrastructure through continuous flow capacities. This simplification omits the potential economies of scale associated with pipeline sizing. In new pipeline investments, costs typically exhibit economies of scale, meaning that increasing pipeline capacity leads to less-than-proportional cost increases. This is primarily because certain cost components, such as labour, excavation, and permitting, do not scale linearly with pipeline diameter. In contrast, repurposed pipelines bypass many of these construction-intensive activities (e. g., trenching and pipe laying), resulting in a cost structure that scales more linearly with capacity (reflected in the cost figures provided by European H₂ Backbone [105]). Repurposed pipelines would potentially dominate a cost-optimal network configuration due to significantly lower investment costs compared to newly built connections. As a result, the overall impact of this modelling assumption on infrastructure layout remains limited in the context of repurposing-dominated scenarios.

To explore the impact of different H₂ supply strategies on infrastructure needs, we group the green H₂ production pathways, introduced earlier in the text, into two overarching categories, central and decentral production scenarios, representing two contrasting extremes. These are defined as follows:

- **Central:** This scenario includes centralised production and supply pathways, comprising offshore H₂ production, green ammonia imports with onshore dehydrogenation, and pipeline-based green H₂ imports from southern Europe. Both centralised H₂ storage in salt caverns and decentralised storage in liquefied H₂ tanks are modelled as flexibility options to balance intermittent supply with the assumed flat hourly H₂ demand across industrial clusters.
- **Decentral:** This scenario represents distributed, inland H₂ production via electrolyzers located within the industrial clusters of the TCR. As in the central scenario, both centralised (salt caverns) and decentralised (liquefied H₂ tanks) storage technologies are included. The model captures trade-offs between local storage integration with distributed electrolyzers and investments in a transmission network to access centralised storage.

Figure 31 illustrates the system boundaries and key technological components included in each scenario. For the green H₂ import pathway from southern Europe, renewable H₂ production and storage in Spain are modelled endogenously based on regional renewable availability. A dedicated pipeline route is assumed from northern Spain, passing through France and terminating in eastern Belgium (Hainaut-Mons cluster), following the prospective European H₂ infrastructure map [106]. This connection is treated as new-build infrastructure. In contrast, the green ammonia import pathway is modelled exogenously, with prices incorporating terminal handling, shipping costs (based on [107], assuming Morocco as the point of origin).

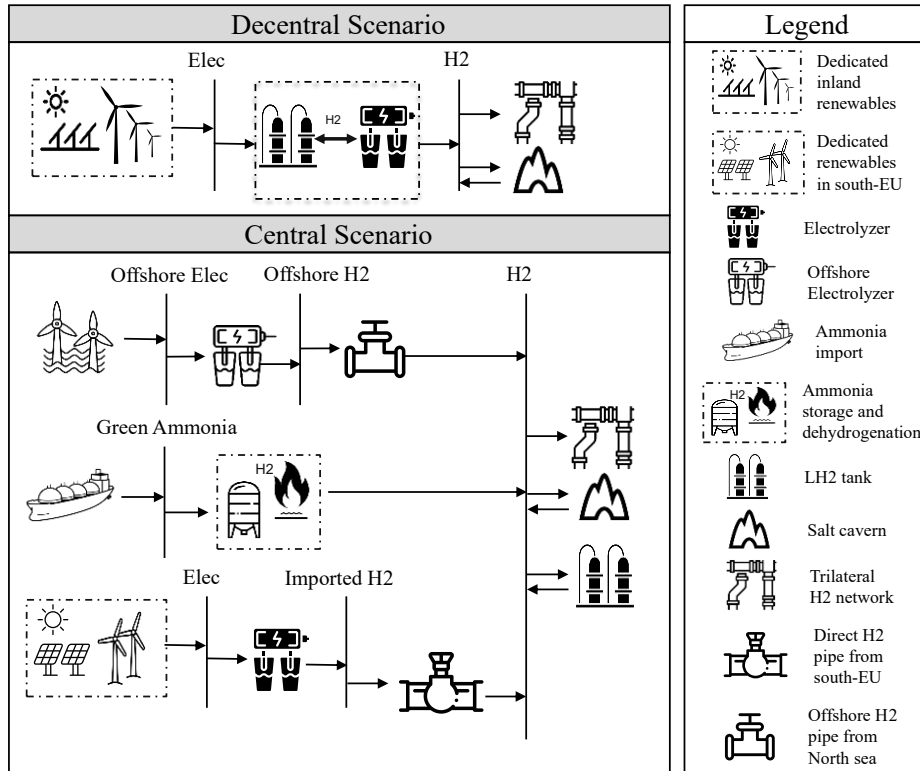

Figure 31. System boundary for green H₂ infrastructure analysis in this study across both central and decentral H₂ production scenarios. Own work.

All assumptions regarding the cost and performance parameters of technologies within the system boundary, including renewable electricity generation, H₂ production and storage, and both new and repurposed pipeline infrastructure, are detailed in Table 20, Table 22 and Table 24 of Annex C. H₂ infrastructure model. Given the critical role of storage in balancing intermittent renewable supply with stable industrial H₂ demand, the techno-economic characteristics of available storage technologies are explicitly represented in the model. Governing formula can be found in Annex C. *H₂ infrastructure model*

Hydrogen infrastructure results

This section assesses how selected green H₂ supply and demand scenarios influence the optimal scale and spatial configuration of H₂ infrastructure in the TCR, with the aim of testing its robustness for long-term planning. Using the linear investment and operational optimisation model described in the previous section, optimal infrastructure layouts are determined for the long-term (2050) horizon. The analysis considers two green H₂ supply scenarios, centralised and decentralised, together with the demand scenarios introduced earlier. Overall, green H₂ uptake across the different demand scenarios can be grouped into the following categories:

- **Green H₂ adoption by both the refinery and fertiliser sectors:** This outcome occurs under stringent policy conditions represented by the RED III and Net Zero scenarios. In both cases, the fertiliser sector replaces on-site grey H₂ production via steam methane reforming with green H₂ purchased from the market (with a total volume of 27.5 TWh/a. Under the RED III scenario, refineries use green H₂ only for marginal hydrotreatment (with total volume of 0.9 TWh/a) for producing fossil-based products, integrated with carbon capture and storage (CCS). In contrast, under the Net Zero scenario, refineries shift to a production mix based on Fischer-Tropsch synthesis and biomethanol pathways, resulting in slightly lower green H₂ demand (1.4 TWh/a).
- **Green H₂ adoption only by the refinery sector:** In all other demand scenarios, including Global Effort, Limited biomass, and Maximum biomass, RED III is cost-competitive solely for marginal hydrotreatment applications in refineries.

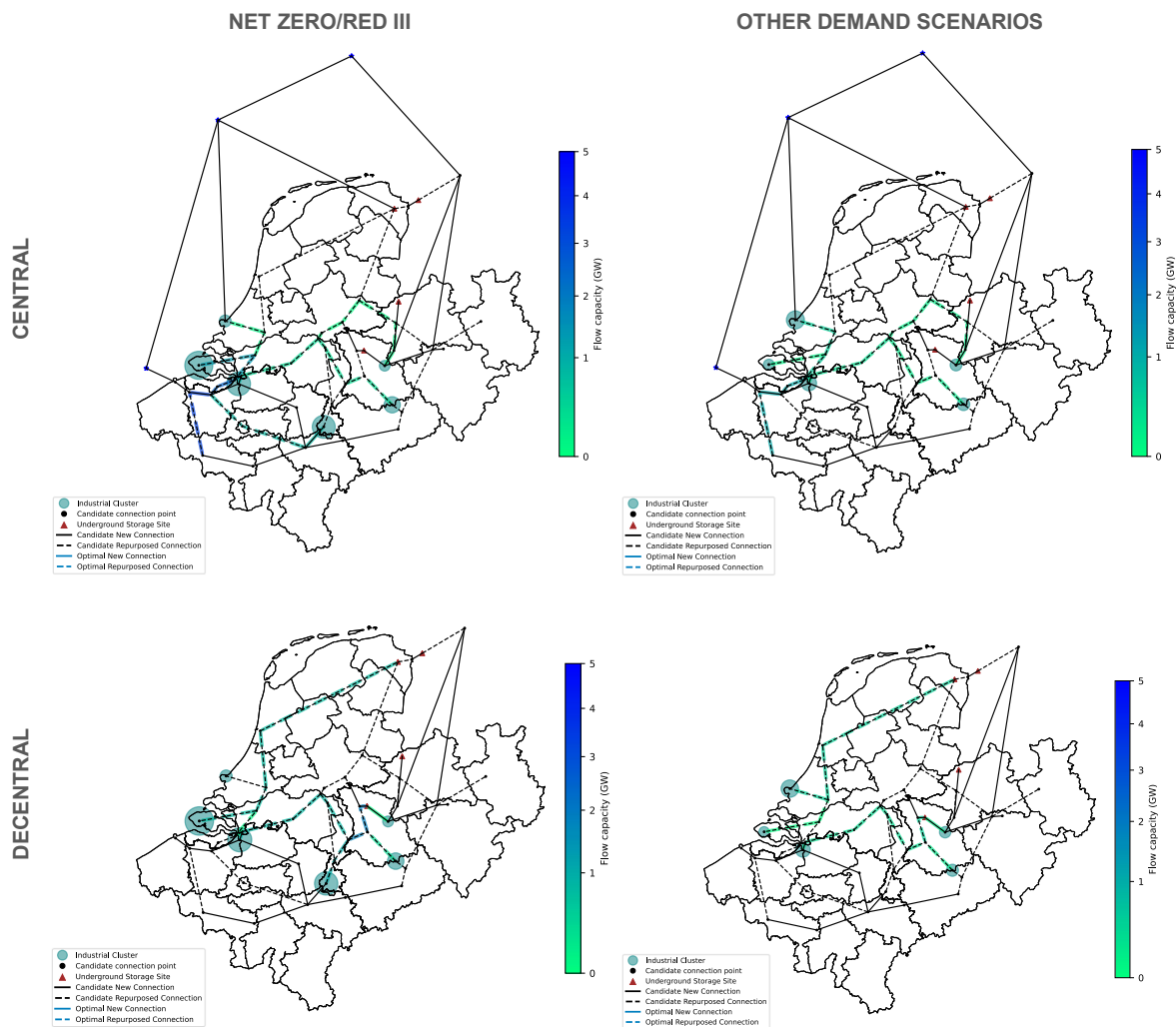

Figure 32. Optimal H₂ infrastructure layout in 2050 in the TCR across defined demand and supply scenarios under optimistic calculation of Levelised Cost of H₂ (LCOH). Own work.

The infrastructure optimisation results as in Figure 32, indicate that pipeline repurposing consistently emerges as the preferred option, with the overall network topology mainly shaped by where repurposing opportunities already exist. Repurposed long-distance pipelines are often more cost-effective than newly built shorter segments, and although supply and demand assumptions influence the placement of import terminal connections, centralised storage sites, and routes toward industrial clusters, their



impact on the broader topology remains limited as it already connected to existing clusters. That is why the H₂ pipelines, as a transit between North Rhine-Westphalia and industrial clusters, are mainly installed in the Netherlands, as salt caverns are present and more pipelines which can be refurbished are available, whereas in Belgium a hydrogen network would mainly consist of new pipelines. Across all scenarios, total hydrogen flow volumes stay relatively low, pointing to a potential long-term risk of underutilised pipeline infrastructure. For production and storage, the results show that offshore hydrogen production and ammonia imports with dehydrogenation are not cost-competitive in the centralised scenario, primarily due to high capital costs for offshore wind and electrolysis platforms, combined with dehydrogenation energy losses and terminal handling costs. Under the decentralised scenario, underground geological H₂ storage accessed via dedicated pipelines is more cost-effective than decentralised liquid storage tanks at industrial sites, owing to lower energy capacity costs and reduced storage losses despite slower response times and added network investment needs. Consequently, centralised salt cavern storage stands out as the most economical flexibility option, underscoring the importance of enabling timely permitting for such facilities to support future hydrogen system development.

The LCOH is estimated using a cost-based approach that annualises electrolyser, storage, and dedicated renewable generation costs. A stylised single-node optimisation model, initially excluding H₂ transport infrastructure, determines the optimal mix of renewable generation and electrolyser and storage capacities based on hourly renewable availability under each supply scenario, meeting a constant 1 GW H₂ demand profile throughout the year. This method explicitly accounts for renewable variability, which governs electrolyser utilisation and storage operation. By including H₂ storage directly in the cost calculation, the analysis estimates the cost of reliably meeting a defined H₂ demand profile, rather than just production cost, resulting in a more realistic representation of end-use H₂ prices and highlighting the value of cost-effective storage in reducing system-wide LCOH formulated in Equation 1.

$$LCOH_y = LHV_{H_2,y} \left(\frac{invcost_{ELZ,ST,RES,y}^a + fixcost_{ELZ,ST,RES,y}^a + varcost_{ELZ,ST,RES,y}^a}{\sum_{t \in T} D_{H_2,y}^t} \right)$$

Equation 1. Levelised Cost of Hydrogen.

In this study, the above methodology is referred to as an optimistic H₂ price scenario, as it assumes flexible electrolyser operation within a cost-based framework and does not rely on retail electricity prices, which in the TCR include high grid fees and tariff components. To assess the robustness of the results, a sensitivity analysis is therefore conducted to examine the impact of more realistic H₂ price assumptions on industrial green H₂ adoption across the different demand scenarios. Table 24, Annex C, represents the LCOH values under both optimistic and realistic H₂ price scenarios.

Under these more realistic H₂ price assumptions, the Net Zero scenario yields a result broadly comparable to those obtained under the optimistic pricing case. In contrast, the RED III scenario results in green H₂ adoption only within the fertiliser sector Figure 33, driven by stringent policy requirements that mandate minimum shares of renewable H₂ in this sector. All other demand scenarios lead to near-zero green H₂ uptake across industrial sectors. In other words, when assuming realistic green H₂ prices that account for grid fees, taxes, and levies, together with a conservative operating assumption of baseload electrolysis without H₂ storage, green H₂ is not cost-competitive for most industrial applications compared to alternative bio-based or fossil-based pathways integrated with CCS. Exceptions arise only under stringent EU-level policy frameworks, such as RED III or Net Zero industry targets, where regulatory constraints effectively enforce green H₂ adoption.

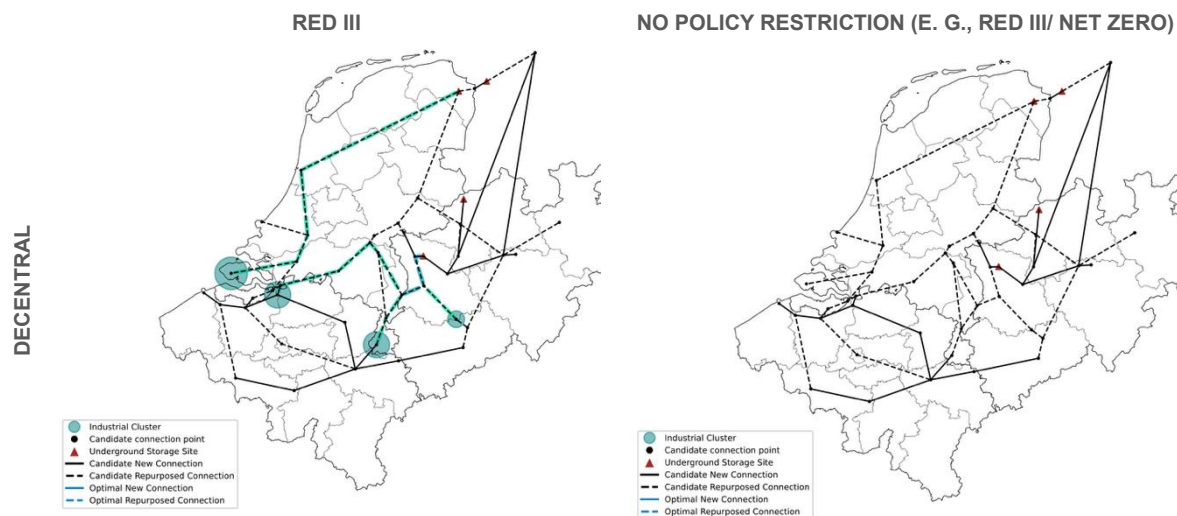

Figure 33. H₂ infrastructure under realistic calculation of LCOH across the TCR in 2050. Own work.

Hydrogen infrastructure conclusions

Industrial activities remain a major source of EU greenhouse gas emissions, accounting for roughly one fifth of the total despite significant reductions since 1990. Meeting EU climate targets therefore requires deep defossilisation of energy-intensive industries, moving beyond incremental efficiency gains toward structural shifts in production systems. Many emerging defossilisation pathways depend on renewable and low-carbon inputs or CCS, all of which demand dedicated infrastructure and long-term investment.

- In this policy landscape, EU instruments such as the ETS, the Clean Industrial Deal, the Net-Zero Industry Act, and the revised RED III play central roles by combining carbon pricing, industrial support, and sustainability criteria for fuels. RED III particularly affects the economic viability of H₂-based pathways by defining renewable H₂ requirements, while the 2024 ETS reform, including the integration of CDRI such as bio-CCS, shapes incentives for CCS-based industrial routes. Understanding how EU policy influences low-carbon technology choices and infrastructure needs is therefore essential. Findings are shared with industrial stakeholders and network operators (e. g., Fluxys, Gasunie and OGE) through related projects such as the Trilate Project [108] and stakeholder meetings in the course of the 3C-VaCS project.
- **Limited cost competitiveness of green H₂:** Across harder-to-abate sectors (steel, refineries, fertilisers, high-value chemicals, glass and cement), green H₂ from onshore hybrids, offshore production, or imports (e. g., Spain) is generally not cost-competitive, even under optimistic assumptions, such as flexible electrolyzers with low-cost storage, ETS prices of 480 EUR/tCO₂, and natural gas at 32 EUR/MWh. CCS-based and bio-based options typically deliver lower-cost defossilisation.
- **Conditional viability of green H₂:** Green H₂ becomes viable only under restrictive conditions, specifically when CCS and domestic biomass are excluded and negative emissions from bio-CCS are not credited. Under such constraints, green H₂ may play a role in refinery hydrotreatment or in direct reduction of iron in steelmaking where CCS (e. g. used to produce blue H₂) is unavailable. Regulatory requirements such as RED III may still mandate green H₂ use in fertiliser production, even when CCS-equipped SMR remains more cost-effective.



- **Implications for H₂ infrastructure planning:** Robust network planning must be grounded in sector-specific cost thresholds and operational flexibility enabled by strategic infrastructure investments. Although network investments can link cost-effective production, demand clusters, and storage sites, green H₂ adoption remains viable only under restrictive assumptions. This highlights the need for coordinated planning across H₂ and CO₂ value chains, as well as awareness of domestic green-fuel alternatives, to avoid overestimating H₂ demand and creating underutilised, capital-intensive pipelines.
- **Priority of pipeline repurposing:** Infrastructure optimisation consistently favours repurposing existing pipelines over new-built infrastructure, with topology largely shaped by available repurposing opportunities. The Netherlands has more pipelines which can be repurposed than Belgium. Repurposed long-distance pipelines are often more cost-effective than newly constructed short links. Early coordination of H₂ and CO₂ planning is therefore essential to prevent stranded assets and avoid high tariffs for early adopters.
- **Non-binding market interests:** Discussions with CNOs in Flanders, the Netherlands, and NRW reveal competitive dynamics between Belgium and the Netherlands in serving Germany's potential H₂ demand and CO₂ removals. While competition may reduce tariffs, coordinated tariff structures and joint evaluation of infrastructure options are required to avoid tariff stacking and underutilised assets, especially under non-binding demand indications.
- **Cost advantage and system role of blue H₂:** is generally more cost-competitive than inland or offshore green H₂ production, as green H₂ imports from Southern Europe, or ammonia imports with dehydrogenation suffer from reconversion losses and terminal costs. Since many clusters already operate SMRs, retrofitting CCS and transporting CO₂ to storage sites is typically cheaper and less risky than building entirely new SMR+CCS hubs with new pipeline networks.
- **Levelised costs of H₂:** LCOH analysis shows renewable electricity is the dominant cost driver of green H₂ (60-70 %), followed by electrolyser CAPEX (≈25-30 %), while storage and transport contribute relatively little. Reducing green H₂ costs therefore requires lowering electricity costs and enabling highly flexible operation, supported by affordable storage options like salt caverns.

3.4.2 Infrastructure implications for CO₂ networks

The Industrial Carbon Management strategy (Feb 2024) highlights the EU vision on the need for significant amounts of carbon capture (>400 MtCO₂) by 2050 [109], partly related to utilisation (CCU), but mainly to storage of fossil CO₂ emissions (CCS) and to storing air-captured or biogenic captured emissions (CDR: Direct Air Capture CCS or DACCS, biBioenergy CCS or BECCS). While CO₂ capture typically represents the largest cost component, transportation and storage should not be neglected. Together these elements are often referred to as the “CO₂ value chain”. Due to its highly industrialised region and proximity to North-Sea storage locations, the BE-NL-NRW region has a high potential to deploy industrial carbon capture solutions, with the chemical industry playing a central role.

CO₂ infrastructure modelling approach

Understanding the potential volumes of CO₂ that could be captured in the future under various scenarios, as well as the associated transportation and storage needs, is crucial for coordinating the CO₂ value chain developments and avoiding costly capital investment lock-ins. More specifically, by using a scenario-approach and looking at economies of scale, this study aims to understand the impact of the following aspects and answer the related questions:

- **EU carbon pricing:** How does CDR crediting influence the CO₂ value chain in terms of bio-CCS/fossil-CCS adoption and resulting volumes and pipeline routing? (cf. five base scenarios without vs. with CDR credits)
- **Industry relocation:** How do increased imports affect scale economies that are essential in the rollout of a CO₂ value chain? (cf. Global effort scenario)
- **Biomass use:** Which scenarios are most reliant on biomass recourses? (cf. limited vs. maximum biomass scenarios)

Methodology

A European spatially resolved carbon capture, transport & storage (CCTS) model has been used. It optimises the total costs of the capture decision in relation to other decarbonisation options together with the cost of transport and storage components. A similar modelling scope Figure 29 and workflow (Figure 30) as the one used for H₂ is applied to examine the role of industrial carbon capture within the TCR.

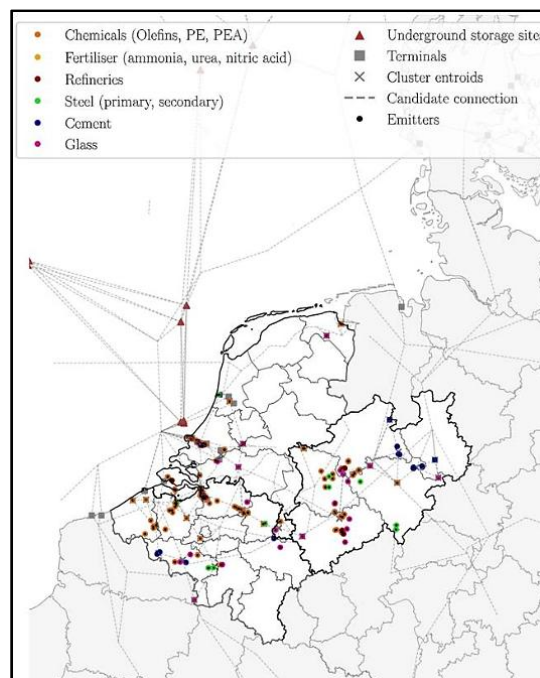

Figure 34. Modelled TCR region, six industry sectors, candidate pipelines, storage locations and terminal points. Own work.

Industrial data such as location, products and production volumes, is obtained from the AIDRES database [102], similar to the the H₂ infrastructure model (Figure 35). This includes geographical data from six main industries as shown on Figure 34. First, a data processing step selects two types of routes per production facility in correspondence with the applied scenario: (i) the minimal total expenditure (TOTEX) route and (ii) the minimal TOTEX route without carbon capture. In some cases, (i) and (ii) are equal if the minimal total cost route does not involve capturing. In the other case, when (i) involves carbon capture, the production route in (ii) serves to provide information on the value of connecting a certain emitter to the CO₂ value chain. In other words, when the cost difference between (i) and (ii) is very small, the connection costs of the carbon capture site to the CO₂-backbone might surpass the costs of the alternative decarbonisation route (ii). In this way, the CCTS optimisation model will decide

not to connect the emitters to the backbone, and they will decarbonise differently. Connection to the CO₂ network occurs via industrial cluster points as shown with the “x”-markers in Figure 34.

Several novel routes have been added to the AIDRES database [102], covering the use of bio-methanol and bio-naphtha in the chemical sector. Biogenic emissions from biorefineries producing bio-methanol or bio-naphtha from local biomass are assumed to be captured at existing refinery facilities. The total volume of emissions captured from bio-naphtha or bio-methanol production from local biomass is allocated to refineries (or their respective clusters) in proportion to each cluster’s share of current refinery output relative to total BE-NL-NRW production.

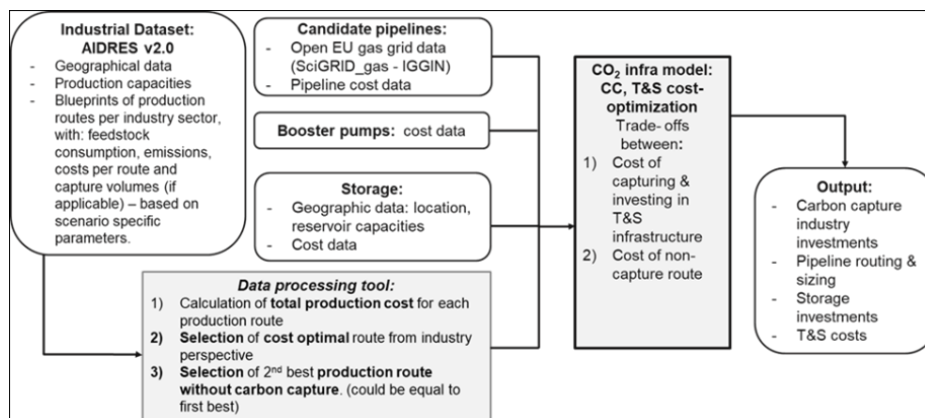

Figure 35. CCTS model inputs and outputs, including a data processing step. Own work.

Besides industrial data, data for transport and storage (T&S) are fed to the model. T&S components are optimised together with the capture decision. Candidate pipelines are extracted from the Scigrad database [110] containing a collection of open-source European gas transport data. The pipeline construction cost data is extracted from Rubin et al. [111] (see Figure 3.8.1-3) and verified with the Danish Energy Agency database [112]. Repurposing existing natural gas pipelines is not included within the model. Storage and booster pump data has been derived from the IEA database [113]. Note that the model does not allow to store CO₂ in UK territories for the year 2030. This is related to different ETSs (UK ETS, EU ETS), which do not allow storage of CO₂ in UK sinks to date. In 2050 UK storage sites are included assuming the permission for CO₂ storage.

We model pipelines and storage sites using lump-sum investment costs. That means that each component has an initial fixed cost. This mimics scale economies associated with the concept of “network externality”, where infrastructure costs decrease for all participants of the CO₂ value chain when the captured and transported volume increases. Hence, a mixed integer linear programming formulation is implemented as shown in

Figure 36. Pipelines furthermore scale linearly with capacity and length.

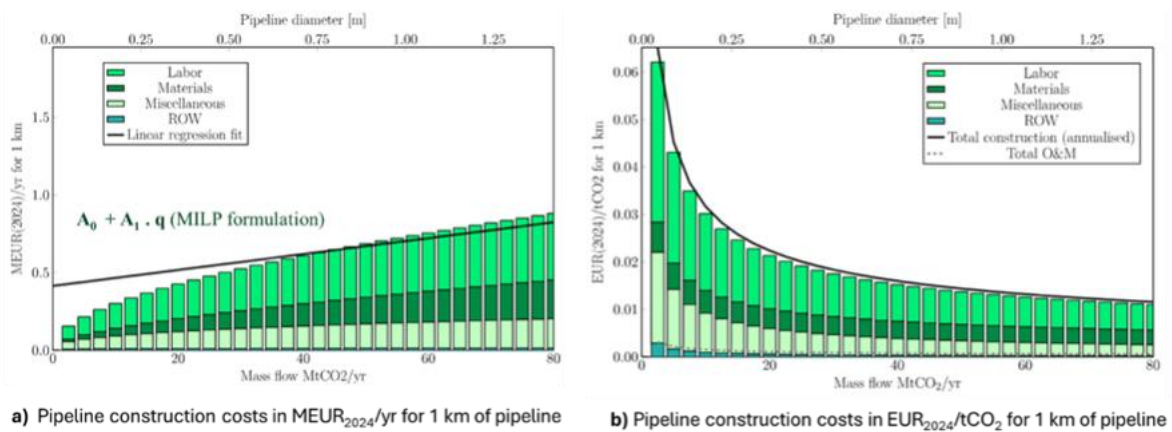

Figure 36. Annualised CO₂ pipeline construction and maintenance costs. Materials: cost of pipe, coating, and cathodic protection. Labour: construction labour. ROW: cost for the right-of-way permit in relation to building the pipe and potential damages to landowners’ property during construction. Miscellaneous: costs of engineering, supervision, contingencies, telecommunications equipment, freight, taxes, allowances for funds used during construction, administration and overheads, and regulatory filing fees. Data on cost fractions obtained from [111].

The model decides which and how industrial sites should relate to potential storage locations using a centralised, cost-optimal point of view. This translates output data about specific quantities and costs which should be interpreted carefully. Broader scenario or policy related effects are more important than pure quantitative outcomes. We furthermore do not represent other perspectives like social acceptability, security of supply (e. g. transport redundancy), other permitting issues or market-based approaches like those established by the carbon network operators in the modelled region.

Scenarios & sensitivity runs

In total 60 base scenario combinations have been run, together with additional sensitivity runs. Each of the five base scenarios, as listed above in Chapter 3.2 have been combined with the three different H₂ price scenarios (realistic, optimistic and pessimistic), Annex B., and with and without CDR credits. This makes 30 scenarios, run both with 2030 and 2050 scenario parameters.

The CDR credit scenarios are particularly relevant for the CO₂ value chain as they reward industrial bio-CCS with the negative value of the 2030 and 2050 applied ETS prices. This mimics the upcoming EU policy agenda to include domestic CO₂ removals into the EU ETS [114].

A sensitivity analysis has been applied on cross-border connections between BE-NL, NRW-NL vs. NRW-BE to understand the relative value of certain gateways between countries. Similarly, also the inclusion of UK storage has been assessed to understand its importance.

CO₂ infrastructure results

The result section is split in two parts, discussing the base scenarios first, followed by the sensitivity analysis. Since the hydrogen prices do not affect either the number of CO₂ capture sites or the total volume of CO₂ captured, only results for the realistic hydrogen price scenarios are shown.

Base scenarios

The main quantitative scenario results are collected in Table 25 and Table 26 of Annex D for the years 2030 and 2050, respectively. Note that these results encompass all 6 main industries. We make more

detailed reflections for the chemical industry as well. The main observed trends and results are elaborated in detail in the following section.

Trends across 5 base scenarios

Total capture volumes vary by a factor 5: from around 15 up to around 80 MtCO₂ captured per year. The highest volumes are obtained in 2050 with CDR credits applied. This is related to the capture of biogenic emissions, partly during the production of bio-naphtha/bio-methanol. Those biogenic captured emissions do not occur in the global effort scenario, because bio-naphtha and bio-methanol are assumed to be imported.

Average infrastructure costs vary by a factor 3: from as low as 26 EUR/tCO₂ to up to 77 EUR/tCO₂. The highest costs occur under the global effort scenarios characterised as well by the lowest capture volumes. Note that those average infrastructure costs do not say anything about the actual tariff, nor do they say something about system costs. The total system costs also include the upstream industrial production and investment costs.

In terms of pipeline layout, the different scenarios show quite similar pipeline layouts. We test the robustness of the results and relative cost differences in more detail under the sensitivity analysis part.

2030 vs. 2050

Capture volumes in most scenarios increase from 2030 up to 2050. For the net-zero scenarios and global effort scenarios the volume slightly reduces. In 2050, investments in UK storage sites are more cost-effective than more distant Norwegian storage sinks. A comparison of 2030 and 2050 results is shown in Figure 39 for the limited biomass scenario with CDR credit.

Chemical industry

Figure 37 and Figure 38 show a Sankey diagram for 2030 and 2050, respectively, covering the five base scenarios with CDR credits (figures a) and without CDR credits (figures b). Note that the thickness of the flow indicates the amount of production sites and not their capture volume.

2030: The chemical industry in 2030 is dominated by natural gas routes with carbon capture. In the global effort scenario and net-zero scenario, a switch to electrified routes occurs for organics such as Poly-Ethyl-Acetate (PEA) and polymers like PE and to (mixed) biobased production with carbon capture in the case of olefines.

2050: The production of organics (PEA) and polymers (PE) is dominated by fossil routes with carbon capture, together with limited electrification, for the limited biomass, maximum biomass and RED III scenario. For the net-zero and global effort scenario, there is an almost full electrification for the production of organics and polymers. With CDR credits, olefines are produced via a (mixed) biobased route with carbon capture across all scenarios, using either bio-naphtha or bio-methanol. Without CDR credits, the (mixed) biobased route is only selected for the net-zero and global effort scenario.

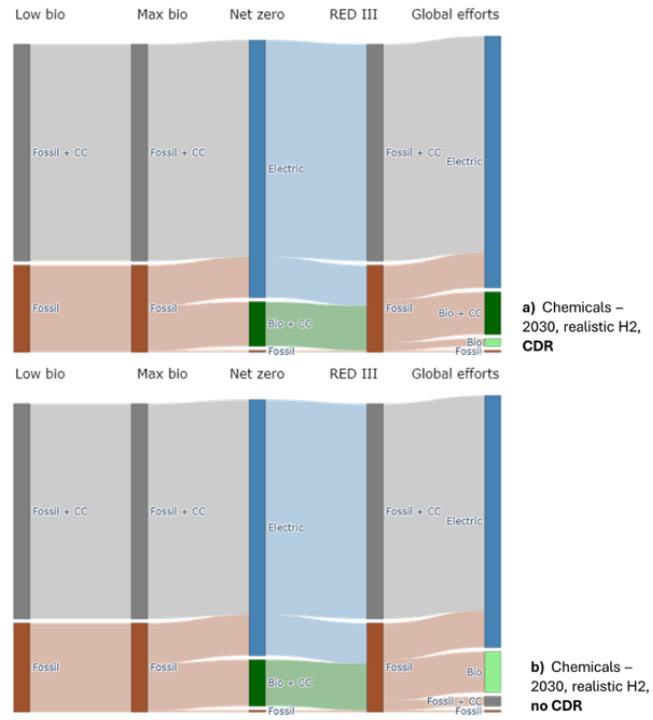

Figure 37. Sankey diagram of the chemical sector incl. organics (PEA), polymers (PE) and olefines. The columns indicate the 5 baseline scenarios. Figure a) depicts the 2030 results with CDR credits, figure b) without CDR credits. Note that the thickness of the flow indicates the amount of production sites and not their capture volume.

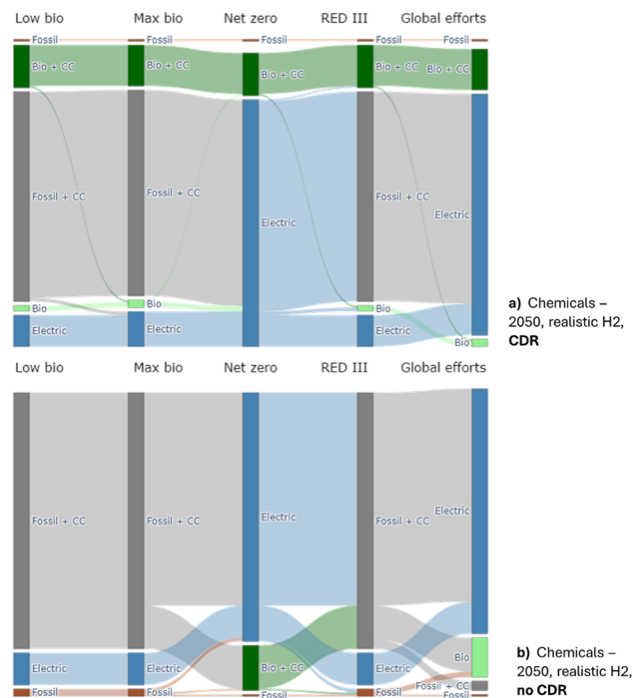
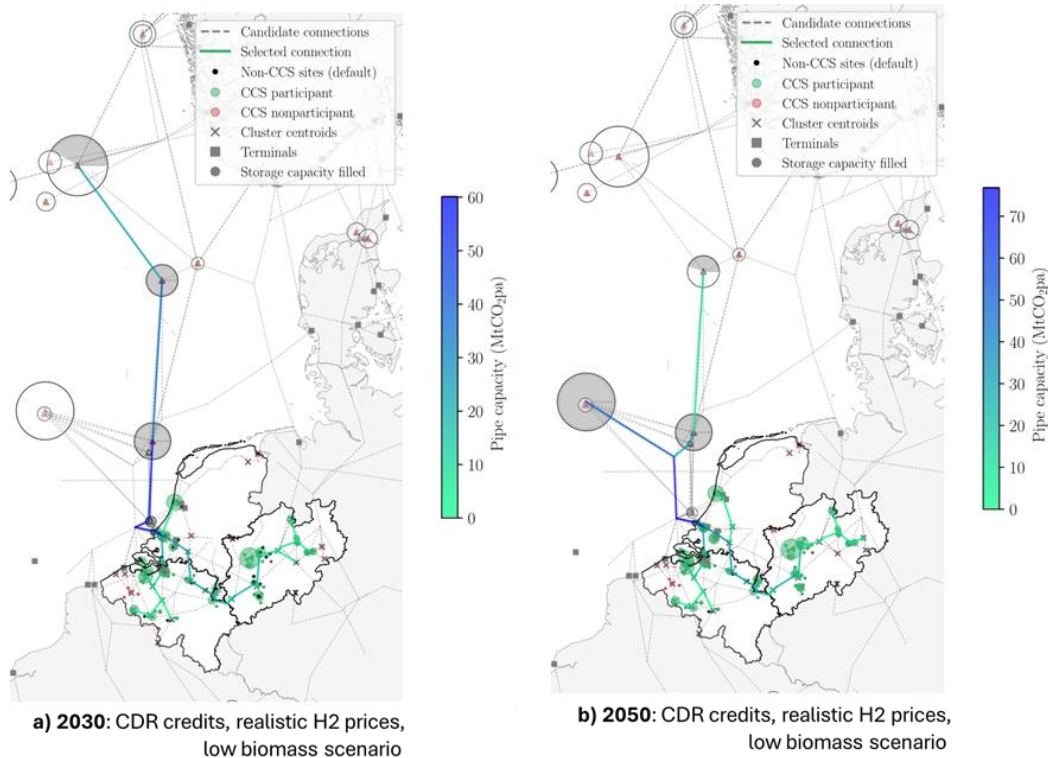

Figure 38. Sankey diagram of the chemical sector incl. organics (PEA), polymers (PE) and olefines. The columns indicate the five baseline scenarios. Figure a) depicts the 2050 results with CDR credits, Figure b) without CDR credits. In Figure a) olefines will be produced nearly entirely via mixed bio-routes with MEA capturing which get rewarded with CDR credits. Note that the thickness of the flow indicates the amount of production sites and not their capture volume.



The scale at the right of each figure depicts the pipeline size. Red dots are CCS nonparticipants who decarbonise differently. Filled storage sites are indicated with a pie diagram (a full circle means that the storage location is full).

Figure 39. Comparison of pipeline and storage investments for 2030 (figure a) and 2050 (figure b), both for realistic H₂ prices and with CDR credits.

The CDR credit effect:

CDR credits increase the total CO₂ emissions capture volume across all scenarios. The increase is caused by bio-based capture at the industrial site (employing bio-CCS). There is a partial substitution effect as most of those sites transition from fossil-based CCS to bio-CCS. Indirect bio-based capture at biorefineries: up to 10 Mt CO₂ of biogenic emissions are captured at biorefineries to produce bio-naphtha or bio-methanol based on local biomass. 2050 scenarios with CDR credits make use of biomass resources. This could drive up competition and biomass prices, which are now modelled exogenously.

CDR credits do not affect the chemical industry in 2030. However, olefines all switch to mixed-bio-based production routes in 2050 scenarios, as shown in Figure 37 and Figure 38.

Although most scenarios are characterised by the NRW-BE connection, the global effort scenario in 2030 without CDR credits does show a cross-border switch from NRW-BE to the NRW-NL connection. This is shown in Figure 40, which shows the contrast between the global effort scenario with (a) and without CDR credits (b). Consequently, due to the NRW-NL pipeline, some emitters are not connected. Reversing the analysis, CDR credits enable a higher willingness to pay from those emitters along the NRW-BE pipeline, which establishes a cost-optimal connection between NRW and BE. As shown in the sensitivity analysis, the relative cost difference infrastructure wise is negligible.

Scale economies:

The level of nonparticipants across all scenarios, except for global effort, generally lies between 2-4 % related to volume and between 5-15 % related to site location, with only one outlier of around 10%v for the net-zero scenario with CDR credits in 2050 (Table 25 and Table 26 in annex D). Nonparticipation is generally higher for the global effort scenario, with nonparticipants accounting for 7-12% in terms of volume and 10-30% in terms of site location, which is probably related to the lower amount of total carbon captured. The nonparticipants decarbonise differently from a cost-optimal perspective, considering the applied cost parameters for the industrial routes, pipelines, booster pumps and storage locations. Nonparticipation is caused by two main effects:

- Small, remote emitters are not connected as those would increase the costs for all industries disproportionately due to missing scale economies.
- Storage locations are filled up. That means that building a new offshore pipeline and commissioning a new storage facility increases the costs for all emitters sub-optimally.

Additional cross-border and geographic **sensitivities** are available in Table 27 in Annex D.

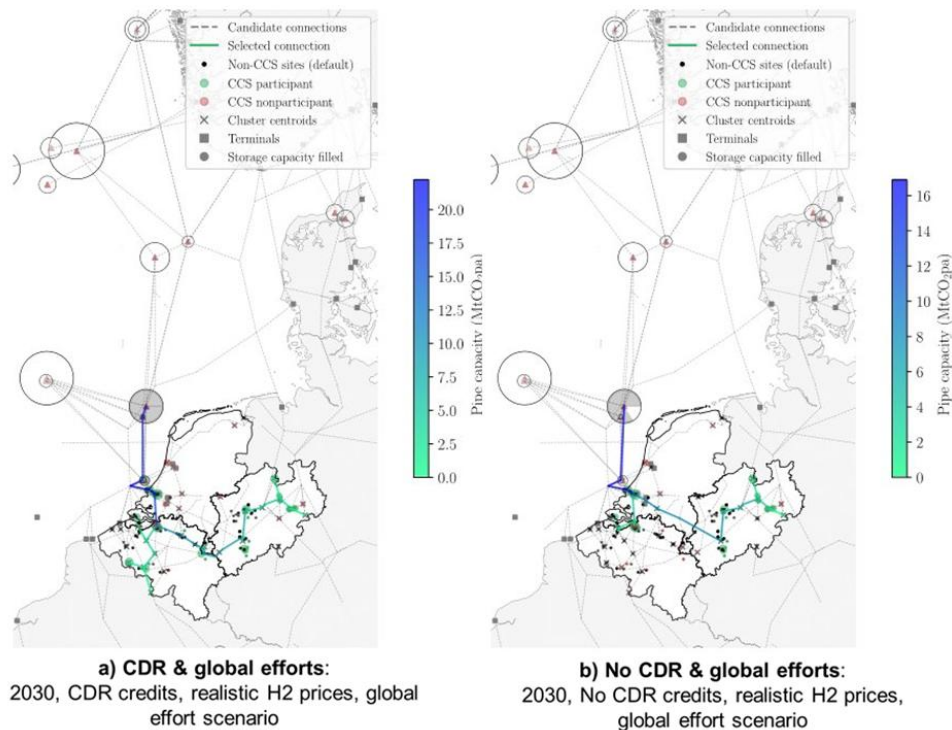

Red dots are CCS nonparticipants who decarbonise differently. Filled storage sites are indicated with a pie diagram (a full circle means that the storage location is full). Selecting the Delta Rhine Corridor(line results in several sites not connecting to the network (red dots). Most scenarios show the same routing results, with minor changes. The global effort scenario is more sensitive to the selection of the NRW-BE or NRW-NL connection. The latter results in several sites not connecting to the network.

Figure 40. Difference in pipeline routing between the 2030 global effort scenario with and without CDR credits. The scale at the right of each figure depicts the pipeline size.



CO₂ INFRASTRUCTURE CONCLUSIONS

We outline several overarching conclusions that emerge from the results presented above, taking a broader, system-level and cross-border perspective.

Carbon capture dominance across industries and policy scenarios highlights the need for forward-looking planning. Our cost-optimisation results show that for most hard-to-abate industries carbon capture is the dominant low-carbon deployment route across most scenarios and industries. Capture volumes in the BE-NL-NRW region could easily range from 15 MtCO₂ captured per year to up to 80 MtCO₂ per year. This requires anticipation from transport operators across borders towards North-Sea ports and offshore storage locations.

Industry clusters are key in creating economies of scale, enabling the CO₂ value chain. Our infrastructure model highlights the importance of dense industry clusters (e. g. the Antwerp cluster) in deploying the CO₂ value chain. The viability of a certain carbon capture investment partly depends on the proximity to other industries due to capital intensive pipeline investments. Remote sites tend to favour decarbonisation routes without novel large scale infrastructure investments as investments in new pipeline requires large volumes (“scale economies”) to be economically viable. Besides, industrial relocation due to a loss in competitiveness reduces scale economies (e. g. global effort scenarios without bio-refinery volumes), resulting in increased costs and reduced investments in the CO₂ value chain. This leads to a partial reinforcing of the competitiveness issue.

Storage proximity is key to limiting CO₂ value chain costs. Our study demonstrates that industrial engagement in the CO₂ value chain is impeded when proximate storage locations are unavailable or already occupied. Access to UK’s territories could provide significant cost reduction, acting as an enabler to the upstream capture industry. Due to different regulations in carbon pricing (EU ETS vs. UK ETS), the EU and its member states have every interest in negotiating access to these sites.

Recognising bio-CCS in the EU ETS significantly increases capture volumes and biomass use, with potential implications for sustainable biomass cycles and required T&S capacities. With inclusion of bio-CCS in the EU ETS legislation, a direct substitution effect occurs from those industries first investing in fossil-CCS (when no CDR inclusion) to bio-CCS (when CDR is included in the EU ETS). Second, in some scenarios bio-CCS at bio-refineries occurs producing bio-methanol or bio-naphtha for the chemical industry. Network configuration remains rather robust to this change in EU ETS regulation (CDR inclusion), but pipeline capacities and storage volumes need to scale accordingly. All in all, CDR inclusion requires efficient coordination and planning of both the CO₂ value chain as the biomass/feedstock residues’ supply chain across regions.

Careful coordination between CNOs in the TCR should allow for efficient deployment of the CO₂ value chain. Our analysis shows that the NRW-BE vs NRW-NL connections do not significantly differ in terms of total modelled infrastructure costs. Hence, it is important that the different regions work together to accomplish a cost-effective and inclusive value chain without double counting of volumes from the NRW region. This also requires efficient cost-reflective tariff schemes which should be implemented without burdening customers due to unnecessary tariff pancaking, cumulative effect of multiple stacked tariffs, in relation to cross-border flows. Lastly, agreeing on the same specifications (pressure, temperature, purity levels) streamlines cross-border cooperation.

Process level calculations are useful to identify long-term economic viability and complement the insights gained by market inquiries. Both for H₂ and CO₂, studying the underlying processes is useful to identify additional market demand, or to identify economic risks in long term network investments based on short term expressions of interest. The final responsibility for investment decisions lies with the network operator, of which the investment plans are approved by the regulator.



3.5 Feedstock and energy costs on global scale under structural policy uncertainty

KEY INSIGHTS

- Electricity prices are generally lower in China and USA, which is essential for decarbonizing downstream processes and provides a competitive disadvantage for European industries.
- Aligned with the conclusion of Chapter 3.3, green molecule production is not expected to be competitive with fossil fuels in the short-medium term in Europe .
- Even at relatively low emission costs of 70 EUR/t, emission costs present a significant increase of the cost of basic petrochemicals production. The decrease in grandfathering emission certificates will hence result in a competitive disadvantage for European companies if global products cannot be subjected to the same costs.
- The Carbon Border Adjustment Mechanism faces several challenges. One of the major challenges is the risk of increasing import of downstream products at the expense of base chemicals or semifabricates, as downstream products are mostly not covered by CBAM.
- As blue hydrogen is in the short-medium term more cost competitive than green hydrogen, implementation of REDIII regarding a share of hydrogen consumption to be green by 2030 will result in a severe competitiveness handicap for the companies subject to the requirement.
- Industrial chemical producers in China or the US have the option to send green products to the European market while supplying unabated fossil products to the home market. This flexibility is not available to European producers and may present a risk for EU producers to diversify and relocate part of their production capacity.

In this chapter, the calculations in Chapter 3.3 are compared with other regions in the world, mainly USA and China. It is important to make the comparison on a global scale. As we have seen in Chapter 3.3, some green processes will be only competitive when a CO₂ price is incurred on emissions of fossil processes. It is then important that such a CO₂ price would result in the local green process being competitive, rather than resulting in fossil import from other parts in the world without any sustainability gains. This chapter aims to quantify this in light of the current regulation. Rather than going into quantitative detail per sector and subsector and aiming to include all possible technological routes, the goal of this chapter is to provide a basic quantitative competitiveness analysis for selected processes. This analysis will serve as a basis for the policy analysis in Chapter 3.6 *Overview of EU policies impacting chemical value chains*, p. 74. This analysis is limited to feedstock, energy carriers and emissions and neglects other costs. CAPEX depreciations, commercial margins, subsidies, and personnel costs are often company specific and hard to generalise. As an order-of-magnitude, these other factors present roughly 20 % of the price of produced olefins.

3.5.1 Parameters and assumptions

The parameters and assumptions for Europe are identical to the assumptions documented in Annex B. For China and USA, a basic assessment was made for costs of feedstock and energy carriers, given in Table 3.

Table 3. Parameter assumptions cross-border comparison.

CURRENT COSTS/ENERGY CARRIER 2030 ASSUMPTIONS (EUR2024)	EUROPE [1]	USA	CHINA
Natural gas (EUR/MWh) [2]	37	12	34
Electricity (EUR/MWh) [3]	129	70,4	82
Oil/gas feedstock products (EUR/t) [4]	627	194	640
Biomass (EUR/t) [5]	230	218	No assumption
Green H ₂ 2030 (EUR/kg) [6]	9.8	7.1	5.5
2050 green pathway assumptions (EUR2024)	Europe	USA	China
Electricity (EUR/MWh)	100	70	80
Green H ₂ 2050 (EUR/kg) [6]	5.4	2.3	2.0

[1] For documentation on EU parameters, we refer to main assumptions in Annex B.

[2] EU wholesale gas prices were 34.4 EUR/MWh Dutch TTF, however retail prices are higher [115]. For high energy consumers (profile G2 in FORBEG ref), prices were 31.2 EUR/MWh in Flanders, 35.6 EUR/MWh in the Netherlands and 45.0 EUR/MWh in Germany. The average of 37.3 EUR/MWh is taken. For USA, natural gas prices are taken from the U.S. Energy Information Administration [116]. The average cost is converted from dollars per Thousand Cubic Feet to EUR/m³ with a factor of 0.02832 and to EUR/MWh with a factor of 10.6 kWh/m³ of natural gas. The financial year for conversion is 2024, with a 0.92 USD/EUR relation.

For China, the natural gas prices are taken from [117]. The regional differences are much more significant than for USA and Europe. Therefore, the gas price is taken as a weighted average between the regions with the highest production of ethylene; Jiangsu (18 %), Guangdong (16 %), Liaoning (11 %), Zhejiang (8 %), Fujian (7 %), Shandong (7 %) [118]. The Chinese currency was converted to EUR using a factor of 0.13 (2024 financial year). The average gas price in China is significantly higher than in USA, and comparable to EU prices.

[3] For current electricity prices in EU, the electricity prices of the three TCR regions are averaged to 129 EUR/MWh, where the German cost estimation is taken for the Amprion transmission operator – E4 profile [115]. The FORBEG study is based on public products, individual companies might have negotiated a slightly more favourable bilateral power purchase agreement, as the Febeliec study shows an average for 120 EUR/MWh [119]. For China, a weighted average was made of the regional differences based on the data in China [120]. Also in USA, a weighted average over the regions was taken [121], [122]. Ammonia and Urea production is mainly present in Los Angeles (35 %), Iowa (23 %), Oklahoma (20 %), Texas (5 %) Georgia (4 %), whereas olefins production is mainly located in Texas, Los Angeles, but especially in Pennsylvania [123]. Electricity price is higher in Pennsylvania than in other states, the average is structurally less costly than in EU and China.

[4] Oil products are subject to a worldwide market with relatively low transport costs, hence the intercontinental differences are less pronounced in comparison with electricity. Comparison is made between the EU Brent average (441 EUR/t, where the cost in China is slightly higher (453 EUR/t) [124]). This is converted to naphta prices, which are slightly higher in China than in EU. For USA, the ethane cost in Texas is taken as a reference, 162 USD/t [125]. Taking into account 1.3 kg ethane is needed to produce one kg of ethylene, and correcting for USD/EUR, yields an assumption 194 EUR/t.

[5] Biomass cost was found to be around 218 EUR/t in USA [126], similar to the EU assumption of 230 EUR/t.

[6] Current green H₂ costs in USA are estimated at 3.5-6.0 USD/kg including support from the Inflation Reduction Act mechanism [127], which provides tax credits of up to 3.0 USD/kg. However the policy is partly being dismantled by the current administration. Therefore, a higher green hydrogen cost of 8.5 USD/kg, or 7.1 EUR/kg is assumed for USA. For green H₂ in EU, the costs are significantly higher, where assumptions are aligned with the values in Annex C, and an average is taken of the realistic cost assumptions in the TCR regions. According to a National Energy Agency report, the buy price of green hydrogen fell to 48.6 Yuan/kg (6.7 USD/kg) [128], less costly than in USA and EU. This is conservatively estimated to fall to 5.5 EUR/kg in the 2030 assumption. However if the current downward cost trend is continuing, the actual buy price of green hydrogen in China may be significantly lower in 2030, as projected in the Stated Policies scenario of the IEA [129].

For 2050, a few low cost estimates are available, e. g. in [130]. In general low prices are assumed for USA and China in 2050 (2.3 EUR/kg and 2.0 EUR/kg, respectively), and a higher price in Europe (5.4 EUR/kg in line with Annex C. The higher long term green hydrogen price assumption in Europe is related to a more limited spatial potential and capacity factors for renewables in the TCR.

For 2050, it is important that cost assumptions need to be interpreted as realistic assumptions and not as predictions of the future. It is indeed not possible to make accurate forecasts for commodities on such long time-scales, as electricity prices are not only impacted by the techno-economic production cost but also by geopolitical trends and the local regulatory framework. For natural gas, oil products and biomass, the prices are assumed to remain constant. For electricity, a slight decrease is assumed for Europe, in line with the assumptions in Annex C, while USA and China are assumed to remain on the same price level.

3.5.2 Competitiveness comparison in a global policy context

In Figure 41, the costs of naphtha-based olefin production are compared between EU and China, for USA the ethane cracking route is shown. As discussed extensively in Chapter 3, technology routes cracking lighter feedstock such as ethane present a more cost effective and energy efficient route for ethylene but do not provide aromatics. In the cost of olefins, only energy and feedstock costs are included. CAPEX depreciation, commercial margins and other operational costs are not included or assumed similar between regions. The feedstock cost of ethane-based olefins is structurally lower in the USA than in the naphtha-based routes in China and Europe. While the naphtha feedstock costs between Europe and China are presenting most of the production costs in absolute terms, these commodities are traded in a worldwide market and hence converge between these regions, whereas the price of electricity is determined locally. Both USA and Chinese companies benefit from lower electricity costs compared to their European peers, giving these regions the advantage for electrification or green molecule pathways.

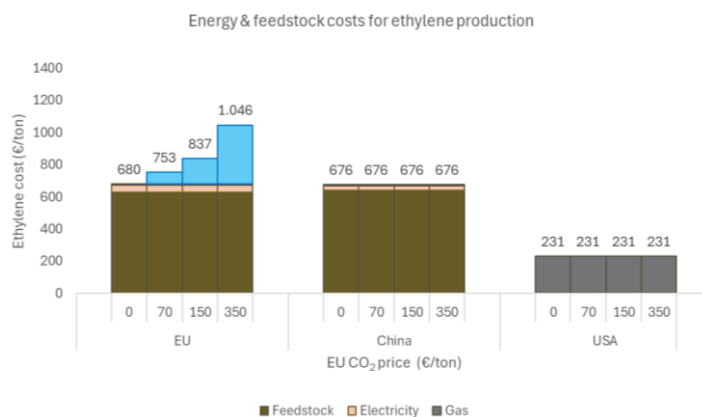

Figure 41. The energy and feedstock cost component of olefin production as a function of CO₂ costs in EU, China and USA.



In addition to energy and feedstock costs, Figure 41 displays emission costs as a function of CO₂ prices. For the EU, the additional emission costs for unabated production of olefins at a CO₂ price of 70 EUR/t, 150 EUR/t, or 350 EUR/t are given. The CO₂ price in EU was 83 EUR/t at the start of February 2026 [131]. Already at these moderate prices, the cost of unabated emissions would have a significant impact on the competitiveness of the product.

A few comments are needed to interpret the figure correctly. Companies are required to surrender allowances for every ton of CO₂ they emit under the EU ETS. This is a cap-and-trade scheme that sets a declining limit on greenhouse gas emissions from power generation, industry, and aviation. Allowances can be traded, ensuring emissions reductions occur where they are most cost-effective, while the overall cap tightens over time.

Free allocation of ETS allowances is allowed for sectors deemed at risk of carbon leakage, provided installations meet EU benchmark and activity-level criteria. The chemical sector is listed as a sector with a high carbon leakage risk. However, this free allocation will be gradually phased out between 2026 and 2034. It is replaced by the Carbon Border Adjustment Mechanism (CBAM), which applies to imports of selected carbon-intensive goods. Due to the free allocation of emission certificates, the top energy efficient petrochemical EU companies today may be facing less costs for emissions than the current CO₂ price. However, as CO₂ prices increase towards 2030 driven by scarcity in the supply of certificates, and the system of free allocation is gradually replaced by the CBAM, companies will effectively face higher CO₂ prices.

These emission costs will present a structural competitiveness disadvantage compared to the production facilities in China or USA. USA does not have a unified single national carbon market, China does have a system with CO₂ prices much lower than in the EU (around 11 EUR/ton CO₂) [132], which don't yet cover petrochemicals, although chemicals can be included in the future. Under the current EU policy, petrochemicals are not yet included in the CBAM, which means that producers in China and USA can export their products to the EU market without paying the EU carbon tax. In addition, the CBAM system currently does not foresee a compensation mechanism for export by petrochemical companies from the EU to regions without carbon markets, presenting EU companies with a structural competitiveness disadvantage on global markets. In conclusion, both emission costs (short term) and higher electricity prices (long term e. g.: for green ammonia production) will probably present a structural disadvantage for EU companies operating on the global market.

Finally, it is important to stress that other costs, such as CAPEX depreciation, personnel costs, commercial margins, maintenance costs or other operational costs are not included in the graph. CAPEX depreciations for instance depend on the local regulatory framework, and (especially in Europe) the historical context of the asset, and cannot be generalised.

In Figure 42, the cost of production of Urea – only the energy and feedstock components – is given as a function of CO₂ price. In comparison, the cost of green ammonia-based urea in 2030 and 2050 are added as well.

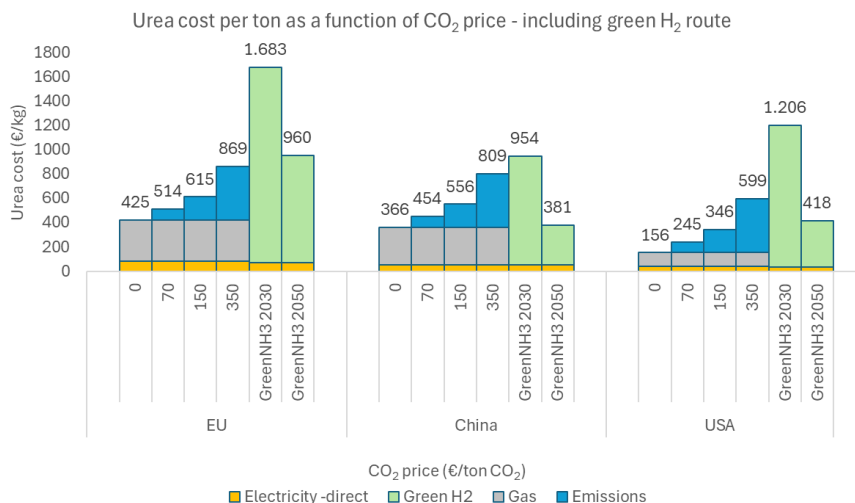

Figure 42. Energy and feedstock components to produce Urea under various CO₂ prices. As a comparison, the green H₂ route to produce ammonia and urea is included as well for 2030 and 2050.

Several conclusions can be drawn from Figure 42. As a disclaimer, caution needs to be taken interpreting the exact quantitative values, especially with the projection of the H₂ cost values. For Europe, the cost of green H₂ will critically depend on the development of the transmission grid and the spatial policies towards renewable energy sources. A conservative H₂ cost estimate by 2050 of 5.4 EUR/kg was taken. In China (2.0 EUR/kg) and USA (2.3 EUR/kg) more optimistic cost assumptions are considered. The more conservative cost of Europe relates to the more limited spatial potential of renewables, in combination with high electricity demand in other sectors in the TCR, competing for renewable energy resources.

A first conclusion of the figure is that the green H₂ route for ammonia production will in the short term be structurally more costly than the fossil-based route, which is in line with the conclusion of Chapter 3. Consequently, if RED III implementation will require the H₂ used in the ammonia process to be green H₂, a severe competitiveness handicap will follow for European producers subject to this regulation. From an economic perspective, it would be more logical to ship ammonia or fertiliser rather than produce it on-site in Europe using electrolysis. As concluded in Chapter 3.2 on the hydrogen supply scenarios, blue hydrogen will on a short term be more cost effective than green hydrogen. Fertiliser products fall under CBAM, and therefore the emissions are also indicated as a cost for non-EU producers.

A final drawback of the CBAM mechanism is outlined in Figure 43. To the left of the figure, a producer is represented which is only active in Europe. During the transition, the producer gradually replaces the fossil production with green H₂ based fertiliser, however paying carbon taxes on the fossil production. The Chinese producer, exporting 30 % of its products to the European market, has the flexibility to send the fossil product to the home market and the green product to the European market.

As a conclusion, the Chinese producer has not only cheaper access to energy and feedstock costs for fossil and green production, in addition this producer can make use of the flexibility to send fossil and green products to the most appropriate market. The EU producer, not having this flexibility, faces higher emissions costs during the energy transition. Hence, we conclude that the current setup of the CBAM may provide an incentive to companies which are currently only active in Europe, to diversify their production to other continents.

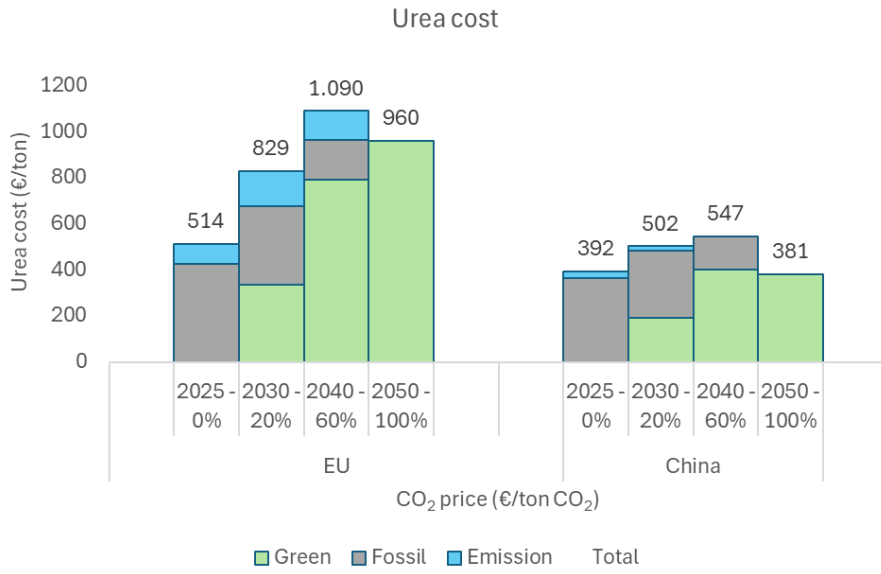

Figure 43. Costs for urea production for a producer active only in EU (left) and a producer active in China exporting 30 % to the EU market (right). The X-axis represents the percentage of products produced using green H₂.

3.6 Overview of EU policies impacting chemical value chains

KEY INSIGHTS

- The current policy package is insufficient to provide competitiveness of the chemical industry in the TCR and major preconditions for industrial transformation are missing.
- The risks of closure/relocation of chemical production and carbon leakage are not fully addressed yet. CBAM exhibits structural challenges that need to be addressed before it can effectively protect against carbon leakage. The Critical Chemical Alliance aims at establishing criteria to identify critical chemical processes and molecules. However, an approach focusing on a limited set of processes bears the risk of i. neglecting the structural challenges the whole industry is facing and ii. unforeseen effects on the value chain.
- The TCR needs to improve cross-border collaboration for correctly dimensioning and routing of molecule network infrastructure, aligning standards and permitting timelines/procedures. Further studies are needed to assess future demand on CO₂ and hydrogen transport as well as supply points connecting to the network, including the role of storage sites.
- The current policy package as well as different options to adapt or complement it were evaluated based on our study results and ii. discussed with stakeholders from the chemical industry. The following options were discussed:
 - Different measures to lower electricity prices,
 - A reform of EU ETS, e. g. with a reintroduction of grandfathering emission certificates or removing the ETS component of the electricity cost,
 - Market pull mechanisms where e. g. consumers (or public bodies) pay a premium for recycled or biogenic content in products to enable sustainable business cases
 - Different policy instruments impacting global trade, such as trade tariffs, safeguards, anti-dumping regulation, etc.
 - Broadening the scope of green hydrogen and hydrogen-based molecules to low-carbon, or providing a clear regulatory mechanism for negative emission revenues from biogenic CO₂ capture and storage.
- Innovation is a key asset of the European industry to diversify the technology options, in which the TCR can take a leading role.

Several political measures address the context of industrial competitiveness, but are in our view not yet sufficient. The **Carbon Border Adjustment Mechanism (CBAM)** for instance aims to help create a level playing field by subjecting imported base products to a carbon price. As we discussed in Chapter 3.5 however, this mechanism is incomplete. Other policy initiatives focus on factors related to geopolitical independence or access to cost effective energy carriers. For instance, the **Circular Economy Act** will aim to leverage on waste streams, improving environmental and geostrategic indicators. The **Critical Raw Material Act** includes targets for European access to critical materials, and **Net Zero Industry Act** enforces a share of EU-production requirements for key strategic technologies such as grid components and wind turbines. The **Industrial Accelerator Act** reserves access to subsidies for European based companies. The **Affordable Energy Action Plan**, as a part of the Clean Industrial Deal, urges member states to accelerate investment in renewable energy and cutting unnecessary levies in the electricity costs. However, the current policy initiatives are not yet sufficient to prevent industrial relocation or to provide the stable regulatory framework needed for the chemical industry to achieve sustainable transition locally in Europe. Additional measures will be needed to provide the framework for a competitive chemical industry. This is also why EU regulations have become a focal point of the discussions within this project.

Based on our modelling results, trade data analysis, and the inputs acquired from our stakeholder dialogue and workshops, we discussed and evaluated political instruments and regulations regarding their impact on the chemical industry in the TCR. A key message emerging from both workshops, as



well as from our analyses, is that the presently challenging situation is a shared responsibility and must be addressed through a coordinated effort of all three countries.

The list below comprises policy options derived from our study results. The SWOT workshop led to a first draft of strategies and possible policy actions, which served as a starting point for the subsequent policy discussions (Annex I). They were prioritised and examined in greater detail in conjunction with the modelling results and the trade data analysis, before entering a second discussion with industry stakeholders at the second workshop in December 2025. The stakeholders were invited to evaluate both the current state of as well as the needs for relevant regulations impacting:

- cost gaps of production (i. e. EU vs. non-EU, traditional routes vs. alternative routes),
- resilience of the value chains (short- and long-term), and
- infrastructure and permitting.

This chapter places the arguments developed from the study results and the stakeholders' views that were expressed during the discussions into perspective. These views are briefly summarised in the boxes titled "Stakeholder Perspective" accompanying each topic. Although a year has passed, the conclusions drawn from the first workshop have not lost their relevance.

Disclaimer: The 3C-VaCS consortium will not recommend policies, as developing a regulatory framework, especially for infrastructure development, is a task for stakeholders together with governments based on objective input to which our study may contribute. The consortium would rather see this being elaborated in-depth by policy makers and stakeholders or as part of a potential follow-up study. In addition, it is important to note that the options discussed below do not automatically guarantee the restoration of competitiveness. A combination of several policy interventions and mechanisms might be needed to be effective. It is expected that the global production overcapacity in the chemical sector will continue to exert a downward pressure on the margins, and a stable long-term regulatory framework, which also addresses the specific challenges of the transition, will be required.

1. Carbon leakage is a major threat to the chemical industry in the EU. Additional mechanisms are required to protect the local production from cheap fossil imports.

CBAM is currently the most discussed political instrument to potentially protect the industry against carbon leakage. From the analysis presented in this report, we conclude that CBAM is subject to structural challenges that hinder it from effectively compensating for the emission cost advantages of foreign competitors. The current scope of CBAM and its modalities, even if extended to chemicals, will not be able to guarantee a level playing field, meaning that it will not protect industry completely from climate-related competitiveness challenges and consequent carbon leakage.

- Currently, petrochemicals are not included in the scope of CBAM. Including them will increase administrative costs and complexity while offering only limited protection for the European industry. Addressing the other fundamental shortcomings mentioned below is seen as a condition sine qua non before including chemicals under CBAM.
- CBAM currently does not apply to products further down the value chain (e. g. for indirect emissions of materials in consumer products, such as cars). In this way, including chemicals under CBAM might risk replacing imports of base products with imports of finished products, reducing welfare generation in Europe and increasing geopolitical dependencies.
- CBAM is not correcting for export of products to regions outside Europe, where European companies will not be able to compete with companies who are not subjected to CO₂ emission costs. The export-oriented European chemical industry would be subject to a significant cost-disadvantage on their export market.

- As shown in Chapter 3.5.2 *Competitiveness comparison in a global policy context*, p. 70, CBAM applies to fossil-based products, however companies active outside Europe may leverage on the flexibility to send green products to EU, where market prices are higher, and fossil-based products to the home market.

Stakeholder perspective

1. Pro CBAM:
 - EU is ahead on CO₂ pricing and CBAM can act as a global decarbonization lever.
 2. Contra CBAM:
 - Extension for chemicals: administrative costs will exceed benefits.
 - Export disadvantages are not addressed.
 - Indirect emissions are not covered.
 - The downstream products are not covered, and would in the case of petrochemicals, require very significant administrative reporting effort.
- ➔ As for the creation of a level playing field, most companies do not believe it is straightforward to fix the challenges related to CBAM by extending it to downstream products. Other measures are required.

The discussions in the 3C-VaCS project focused on several options, ranging from extension or replacement of CBAM with other policies. However, they did not yield a consensus among companies, stakeholders and policy makers. It was acknowledged that CBAM can be a powerful political instrument to extend the impact of EU ETS and to stimulate defossilisation abroad. On the other hand, its capability of creating a level playing field for European production and to protect the industry from carbon leakage was strongly questioned. To achieve the latter, other mechanisms, which for instance exhibit clear incentives for local and sustainable production, such as targeted market pull elements, reduction of energy costs, funding of transformation technology, supporting infrastructure development, are required.

2. A loss of chemical production capacity could undermine Europe's resilience and independence. The EU aims to decide which chemical production and connected value chains are (geo)strategically important to produce within its territory, however this is not a straightforward task.

If no strong intervention is taken, several sectors, such as entire petrochemical value chains, are at risk of disappearing from Europe due to a structural cost handicap. At the political level, parts of the chemical value chain could be classified as 'strategically important' to foster their local production. The **Critical Chemical Alliance** [5] is a current EU exercise that works on establishing criteria to identify critical chemical productions and molecules for the European economy. This classification aims to help safeguard Europe's industrial sovereignty, ensuring that critical components remain available even in times of geopolitical or supply-chain disruptions. Furthermore, the determination of strategic production in the chemical sector might enable the implementation of targeted support mechanisms, such as funding for capacity retention or rapid response measures in crisis situations, as well as policies which prevent overreliance on imports for critical chemicals. Along with e.g. a 'made in Europe' requirement, which is one of the options to be investigated further, specific products could additionally be required to contain a certain share of recycled content to further improve geostrategic independence by leveraging a domestic, currently underutilised resource stream. The TCR, housing the largest chemical cluster in Europe, can play a key role in such a discussion as a facilitator between policy makers, companies, and other stakeholders.



Stakeholder Perspective

Given the high level of integration of sites and the whole region, a focus on defining strategic production sites is considered more practical than defining single strategic chemicals. It is crucial to keep in mind that the chemical value chain is highly interconnected.

- Disappearing of upstream production can result in disappearing of downstream production and vice versa.
- The closure of a plant within an integrated Verbund site might put the whole site at risk by rendering other connected processes uncompetitive, eventually leading to their subsequent closure.

The definition of strategic production however bears the risk to underestimate the interdependencies of the chemical processes in the TCR. Hence, those parts of the value chain that don't reach this classification might eventually be at even greater risk of disappearing. This could, have unforeseen consequences, given the high interdependencies within the cluster. Stakeholders strongly stress this issue, because of which the compilation of a list of critical processes might prove to be extensive as processes are highly interconnected. For instance, if it is considered critical to produce a certain chemical on European soil, the local production of all upstream produced precursors may be critical as well.

3. Transformation-related costs are high. Several options exist to incentivise sustainable production, improve use of circular resources and trigger investments.

Several policies may be adopted to enable sufficient and sustainable production of chemicals on the European continent. Herein, we list a few options and discuss their potential advantages.

Market pull mechanisms could be introduced and broadly accepted across the value chain to account for the higher costs associated with sustainable production, recycled feedstock and low-carbon inputs. Market pull mechanisms, or 'demand creation' must ensure that these (relatively small at the end-product level) additional costs can be passed on at a point in the value chain with limited avoidance possibilities. The revenues from this should flow back to the companies that need to invest in low-carbon and circular production. Such mechanisms could impose requirements on geographic origin or production location of these products, or ensure revenues flow only to European producers.

The concept of circularity should be placed at the core of the chemical industry's transformation to improve the sustainability performance, the sector's resilience and its perception by the public. At present, additional costs for processing recycled or renewable feedstock often cannot be passed on to downstream customers, undermining incentives for investments in greener technologies. A harmonised market framework could help internalise environmental costs, making sustainable choices economically viable and competitive.

However, the key challenge for any kind of market pull system will be the reporting challenge. If costs are to be incurred to the end consumer or public authorities for low-carbon, EU-produced or recycled content in products, a reporting system needs to be in place to track down the upstream production processes in the value chain of a certain chemical. During the workshop, we discussed several reporting systems such as the book and claim system [133]. Whichever system is chosen, it is of crucial importance that any reporting mechanism to track products down the value chain is met with concrete revenues for the companies involved. To a certain extent, a similar system is already in place for the products falling under the Net Zero Industry Act. For instance, EU wind turbine offers need to contain a certain amount of EU made products and components. For the chemical industry, the reporting challenges may however be very large, given the diversity of products and processes.



The reduction of domestic cost burdens (especially energy prices and carbon taxes) might be an immediate action to protect the domestic industry. **Electricity cost reductions** in particular will not compromise climate protection targets as they can enhance the competitiveness of low emission projects. This could be realised through tax reductions, selective transmission tariff reductions or compensating a share of the EU-ETS emission costs in the electricity bills of energy intensive companies. In the Netherlands, the IKC mechanism allows companies to recover the emission component in the electricity costs, provided that 50 % is invested in emission reduction, and a similar initiative is found in Belgium and Germany⁷, following the state Aid guideline amendments in 2025⁸. The practical options and market impact for removing or compensating the ETS contribution to the electricity bill were not discussed further in the stakeholder workshops. The legal consequences of such a new regulation on existing power purchase agreements should be further investigated.

Stakeholder Perspective

Stakeholders propose demand-driven measures, such as financial incentives (VAT reduction, tax benefits, subsidies), voluntary carbon labels, and innovative systems like a climate contribution where consumers pay for unpriced CO₂ emissions. These measures should be simple, harmonized, and implemented at the EU level.

There was no consensus on the benefits of a green premium system, a market pull mechanism where end consumers pay for recycled, EU-produced or sustainable feedstock used in the production of a chemical. Some companies expressed concerns about the practical feasibility of a reporting system linking the base of the chemical value chain with downstream processes, others saw the benefits of such a system outweighing the costs.

Regulations could try to limit the additional costs. **Direct subsidies or tax reductions** of climate friendly projects was a discussed option as well. For instance, the Inflation Reduction Act in the USA enabled companies investing in climate solutions to be compensated financially by project subsidies and tax credits. A similar system could be applied on EU or national government level and would potentially enable sustainable investments in Europe.

Carbon contracts for difference are long-term, two-way agreements between governments and companies that guarantee a fixed price for reducing emissions. By bridging the gap between high-cost, low-carbon technologies and fluctuating, low market carbon prices (e. g., EU ETS), they provide revenue stability for industrial emission reduction.

Mandated Climate Contributions (MCC), which fund green investments via climate-related fees on consumer goods, are discussed as an instrument for the creation of demand for locally produced, low-carbon chemicals. MCC are a specific example of how a levy or mandate at the end of the value chain can help finance investments in sustainability so that additional costs can be recovered in the market. Other models exist that vary in intervention point, design and tracking throughout the chain.

In general, strengthening key downstream sectors (e. g., automotive), reducing production costs, and developing effective “market pull” instruments are essential to sustain competitiveness and stimulate domestic consumption of sustainable products.

⁷ <https://www.rvo.nl/subsidies-financiering/ikc-ets>.

<https://www.vlaio.be/nl/subsidies-financiering/compensatie-indirecte-emissiekosten/enkel-voor-ondernemingen-uit-14-sectoren>

⁸ https://ec.europa.eu/commission/presscorner/detail/en/ip_25_3141



4. Competition with other regions with production cost advantages pose a threat to European chemical industry. Several policy instruments exist to protect the local market.

Import tariffs or safeguards are an option to protect EU production from cheap and large-scale imports from other regions. In the steel sector, for instance, temporary safeguards are applicable which require any import above a certain historical volume to be taxed. Trade tariffs could be targeted to a few key products and flexibly adapted to new products according to the most recent situation.

Stakeholder Perspective

The burden of CO₂ taxation must be lowered as an immediate action to ensure short term resilience of chemical production. Adjustment of EU ETS is recommended to achieve resilience. Global overcapacities are also a subject of concern as well as the importance of anti-dumping regulation for the chemical sector.

Trade defence instruments, anti-dumping, anti-subsidy and safeguard measures were also discussed as effective measures that may well protect domestic industry from dumping and cheap imports. However the key challenge, that any protective measures on base chemicals will result in import of products further down the value chain, still needs to be addressed.

The consequences of imposing trade defence mechanisms and trade tariffs were not discussed in detail with the stakeholders and were not the core focus of the study.

5. Permitting infrastructure projects is lengthy and expensive. It takes place on national and/or regional level, which can lead to conflicting regulations for cross-border projects. A key role for the national policy makers, could be to enable the regulatory framework to support timely and effective infrastructure deployment in the TCR.

In the scenarios presented in this study, **CO₂ networks enabling CCS solutions** are part of the most cost-effective solution in the TCR, leveraging on the geologic potential for CO₂ storage in the area. Allowing **revenues for negative emissions (sequestration of biogenic CO₂)** improves the business case for CCS technologies drastically. CO₂ networks require a price on emissions to be cost effective. In addition, all sustainability pathways require a **strong increase in electrification**, and the corresponding need for grid connection capacity for the chemical companies in the TCR clusters. Following aspects are of key importance for infrastructure deployment:

- **Enhanced coordination** in the TCR regarding pipeline infrastructure is key. It is important that discussions between governments, utilities, regulators and industry partners start from a collaborative and not a competitive mindset between the three regions in the TCR. Cost effectiveness of the infrastructure may critically depend on cross-border collaboration. The national governments could consider a stronger focus on cross-border infrastructure initiatives.
- For **H₂ networks** specifically, there is a high risk identified for underutilisation of cross-border pipeline infrastructure. The methodology followed in the 3C-VaCS project is different from the methodology of the regulators in the sense that a techno-economic analysis is made of the underlying industrial processes, while the utilities design their network plans based on market-based inquiries. It would be very important to enhance the dialogue between network operators and interested supply and demand parties to correctly size and design the grid.
- EU and national governments could seek to **harmonise permitting procedures** for the installation of new (cross-border) infrastructures or processes using alternative feedstocks, including related



documentation and reporting requirements. This alignment could accelerate the transition process and reduce the administrative burden for companies operating in multiple countries. Where needed, proactive discussions with local communities need to be organised well in advance of network deployment.

Stakeholder Perspective

Improvement of infrastructure and cross-border pipeline networks for CO₂ and H₂ are existential for some companies. There are several initiatives and projects ongoing. First-mover risks must be mitigated to solve chicken and egg problem with the deployment of new infrastructure. Governments and stakeholders of different initiatives should come together and decide on one project (e. g. pipeline corridor) to be realised in the first place. Overwriting public interest for the realization of crucial infrastructure projects would help give assurance for investors, e. g. by the definition of corridors.

6. Investments in the chemical sector have been stalling in recent years, but innovation is a key asset of the region.

One of Europe's major resources is its technological expertise. Innovation is key to continuously improving the position of our companies in the global market. In the energy/industrial sector in particular, a lot of technology innovation options exist. Making a better use of circular feedstock will not only improve geostrategic dependencies but also spur innovation in handling and repurposing waste streams. Several biochemical pathways, industrial heating, energy storage, grid components, carbon capture and re-use or sequestration projects, are all areas where advanced technology is needed. Innovations within the chemical industry and the circular economy are often linked to electrification of processes (both in terms of processes and heat supply). In addition to alternative feedstocks, this leads to considerable electricity requirements and grid connection capacities. In order to scale innovations to an industrial level, a corresponding expansion of the electricity grid infrastructure and renewable energies is essential. This should be supported politically and infrastructurally. Efforts could include dedicated research projects focusing on cross-border supply systems or dependencies on feedstock and energy sources from outside the ARRA.

Stakeholder Perspective

Subsidies alone will not help to stimulate investments in innovation. Additional market-driven incentives are necessary.

Regarding Transformation:

Current Subsidy Schemes are mainly focused on novel technologies with low TRL. Many alternative processes with high TRL are already in place and could help with the transformation if financially incentivized but are yet not considered by subsidy schemes.



REFERENCES

- [1] 'Trilateral Chemical Region'. [Online]. Available: www.trilateral-chemical-region.eu/
- [2] Cefic, 'Powerpoint 2025 Cefic Facts and Figures'. Dec. 02, 2025. [Online]. Available: <https://cefic.org/resources/powerpoint-2024-cefic-facts-and-figures/>
- [3] 'Negotiations and agreements', European Commission. [Online]. Available: https://policy.trade.ec.europa.eu/eu-trade-relationships-country-and-region/negotiations-and-agreements_en
- [4] 'Plan for stronger EU chemical industry', European Commission. [Online]. Available: https://commission.europa.eu/news-and-media/news/plan-stronger-eu-chemical-industry-2025-07-08_en
- [5] 'The Critical Chemicals Alliance', European Commission. [Online]. Available: https://single-market-economy.ec.europa.eu/sectors/chemicals/critical-chemicals-alliance_en
- [6] 'EU27 chemical business is struggling', cefic. [Online]. Available: <https://cefic.org/resources/cefic-chemical-trends-report-q3-2025>
- [7] 'Länderbericht China', Verband der Chemischen Industrie (VCI), Aug. 2025. [Online]. Available: <https://www.vci.de/ergaenzende-downloads/laenderbericht-china-2025.pdf>
- [8] Petrochemicals Europe, 'Petrochemicals make things happen', Petrochemistry. [Online]. Available: https://static.seekingalpha.com/uploads/2021/10/6/52933525-16335007513653128_orig.png
- [9] 'Transition pathway for the chemical industry', European Commission. [Online]. Available: https://single-market-economy.ec.europa.eu/sectors/chemicals/transition-pathway_en
- [10] ECSPP, 'Chemical Parks in Europe', Chemicalparks. [Online]. Available: <https://chemicalparks.eu/>
- [11] 'Chemical Parks in Germany', Verband der Chemischen Industrie (VCI), Feb. 2025. [Online]. Available: <https://www.vci.de/vci/downloads-vci/chemical-parks-in-germany.pdf>
- [12] 'Manufacturing Industry Decarbonisation Data Exchange Network – The database version 0.3', PBL Netherlands Environmental Assessment Agency. [Online]. Available: <https://www.pbl.nl/en/publications/manufacturing-industry-decarbonisation-data-exchange-network>
- [13] 'Overzicht GPBV-installaties in Vlaanderen (industrie)', Vlaanderen. [Online]. Available: <https://omgeving.vlaanderen.be/nl/omgevingsvergunning/meer/overzicht-gpbv-installaties-in-vlaanderen-industrie>
- [14] F. Faelli, 'Consumers say their environmental concerns are increasing due to extreme weather; study shows they're willing to change behavior, pay 12% more for sustainable products', Bain & Company. Accessed: Apr. 01, 2026. [Online]. Available: <https://www.bain.com/about/media-center/press-releases/2023/consumers-say-their-environmental-concerns-are-increasing-due-to-extreme-weather-study-shows-theyre-willing-to-change-behavior-pay-12-more-for-sustainable-products/>
- [15] N. Voigt, M.-L. Meyer, J. Stein, S. Deutschländer, A. Wachtmeister, and J. Lee, 'Green Awakening: Are Consumers Open to Paying More for Decarbonized Products?', BCG | Climate Change and Sustainability. Accessed: Apr. 01, 2026. [Online]. Available: <https://www.bcg.com/publications/2023/consumers-are-willing-to-pay-for-net-zero-production>
- [16] 'Plastics the Fast Facts 2025', Plastics Europe AISBL, October 2025. [Online]. Available: https://plasticseurope.org/wp-content/uploads/2025/09/PE_TheFacts_25_digital-1pager-scrollable.pdf
- [17] K. Couch and G. Funk, 'World scale crude to olefins', Digital Refining – Processing, Operations & Maintenance. [Online]. Available: <https://www.digitalrefining.com/article/1002842/world-scale-crude-to-olefins>
- [18] 'European Market Overview', Petrochemicals Europe. [Online]. Available: <https://www.petrochemistry.eu/about-petrochemistry/petrochemicals-facts-and-figures/european-market-overview/>
- [19] 'European chemical closures and investments radar 2022-2025', Roland Berger, Radar report 1 – Commissioned by Cefic, Dec. 2025. [Online]. Available: <https://cefic.org/app/uploads/2026/01/European-Chemical-Closures-and-Investments-Radar-2022-2025.pdf>
- [20] Dr.-Ing. S. Müller, M. Much, and Dr. D. Rolland, 'Pipelineinfrastruktur im Wandel – Von fossilen Molekülen zu nachhaltigen chemischen Rohstoffen und Energieträgern', DECHEMA Gesellschaft für Chemische Technik und Biotechnologie e.V., Nov. 2025. [Online]. Available: https://dechema.de/dechema_media/Downloads/Positionspapiere/260115_Pipelineinfrastruktur_im_Wandel.pdf
- [21] Dr. A. Göbel, Dr.-Ing. S. A. Müller, M. Much, and R. Frindik (MARLO Consultants GmbH), 'Binnenschifffahrt im Wandel – Rückgrat der Versorgung der energieintensiven Grundstoffindustrien', Nov. 2025. [Online]. Available:



- https://www.wasserstoff-leitprojekte.de/lw_resource/datapool/systemfiles/elements/files/f7392308-cf58-11f0-a43b-fa163e7d9971/live/document/Binnenschifffahrt_im_Wandel.pdf
- [22] A. P. Silva *et al.*, 'Naphtha Characterization (PIONA, Density, Distillation Curve and Sulfur Content): An Origin Comparison', *Energies*, vol. 16, no. 8, p. 3568, Apr. 2023, doi: 10.3390/en16083568.
- [23] M. A. Fahim, T. A. Alsahhaf, and A. S. Elkilani, *Fundamentals of petroleum refining*, 1st ed. Amsterdam Boston: Elsevier, 2010.
- [24] F. Kähler, O. Porc, and M. Carus, 'RCI Carbon Flows Report: Compilation of supply and demand of fossil and renewable carbon on a global and European level', Renewable Carbon Initiative (RCI), May 2023. doi: 10.52548/KCTT1279.
- [25] G. Tweddle *et al.*, 'Alternative Naphtha – Replacing Fossil-Based Feedstocks in Refineries and Naphtha Crackers: Technologies and Market, Status and Outlook', nova-Institut GmbH, Jul. 2024. doi: 10.52548/JICP8041.
- [26] eurostat, 'Database'. Prodcom – statistics by product. [Online]. Available: <https://ec.europa.eu/eurostat/web/prodcom/database>
- [27] Statistisches Landesamt Information und Technik Nordrhein-Westfalen, 'Vierteljährliche Produktionserhebung im Verarbeitenden Gewerbe'. 2026. [Online]. Available: <https://www.landesdatenbank.nrw.de/ldbnrw/online?operation=statistic&levelindex=0&levelid=1767865086105&code=42131#abreadcrumb>
- [28] 'Greenhouse Gas Inventory Data - Detailed data by Party', United Nations Climate Change. [Online]. Available: https://di.unfccc.int/detailed_data_by_party
- [29] DEHSt Deutsche Emissionshandelsstelle, 'Emissionshandelspflichtige Anlagen in Deutschland 2024', Umweltbundesamt. [Online]. Available: <https://www.dehst.de/SharedDocs/downloads/DE/anlagenlisten/2021-2030/2024.pdf>
- [30] J. Harnisch *et al.*, 'Chemical Industry Emissions', IPCC, 2006. [Online]. Available: https://www.ipcc-nggip.iges.or.jp/public/2006gl/pdf/3_Volume3/V3_3_Ch3_Chemical_Industry.pdf
- [31] E. Verheggen, 'TotalEnergies houdt krakerbenutting in 2025 stabiel na dip in eerste jaarthelft', Industrielinqs. [Online]. Available: <https://www.industrielinqs.nl/petrochem/2026/02/totalenergies-houdt-krakerbenutting-in-2025-stabiel-na-dip-in-eerste-jaarthelft/>
- [32] 'Cracker closures: facing the inevitable', ICIS Independent Commodity Intelligence Services. [Online]. Available: <https://www.icis.com/explore/resources/cracker-closures-europe/>
- [33] 'Fourth quarter and full-year 2021 results', TotalEnergies. [Online]. Available: <https://totalenergies.com/system/files/documents/2022-02/4Q21-Results.pdf>
- [34] 'Crude Oil Prices: Brent – Europe', Federal Reserve Bank of St. Louis. [Online]. Available: <https://fred.stlouisfed.org/series/ACOILBRETEU>
- [35] 'EU Car Production', acea – Driving mobility for Europe. [Online]. Available: <https://www.acea.auto/figure/eu-passenger-car-production/>
- [36] S. R. OCI Global, 'OCI Global Completes Sale of OCI Methanol to Methanex Corporation'. Jun. 27, 2025.
- [37] 'Shell to abandon methanol production in Wesseling', EUWID Wood Products and Panels. [Online]. Available: <https://www.euwid-wood-products.com/news/companies/shell-to-abandon-methanol-production-in-wesseling-231024/>
- [38] essenscia vlaanderen, 'KERNCIJFERS 2021'. 2021. [Online]. Available: <https://www.essenscia.be/wp-content/uploads/2022/05/chiffres2021-vland.pdf>
- [39] 'Free access to detailed global trade data', UN Comtrade Database. [Online]. Available: <https://comtradeplus.un.org/>
- [40] I. Young, 'Europe's ethylene rationalization begins, more closures needed', Chemweek. [Online]. Available: <https://chemweek.mydigitalpublication.com/articles/europe-s-ethylene-rationalization-begins-more-closures-needed>
- [41] 'Map of major fertilizer plants in Europe', Fertilizers Europe. [Online]. Available: <https://www.fertiliserseurope.com/fertilisers-in-europe/map-of-major-fertiliser-plants-in-europe/>
- [42] Chatham House, 'Resource Trade .Earth'. [Online]. Available: <https://resourcetrade.earth/?year=2022&exporter=56&category=2&units=value&autozoom=1>,
- [43] M. Thomas, 'FEATURE: Poor fundamentals weigh on cumene sentiment, forcing capacity closures', S&P Global. [Online]. Available: <https://www.spglobal.com/energy/en/news-research/latest-news/crude-oil/071123-feature-poor-fundamentals-weigh-on-cumene-sentiment-forcing-capacity-closures>
- [44] eurostat, 'Oil and petroleum products – a statistical overview'. May 04, 2025. [Online]. Available: <https://ec.europa.eu/eurostat/statistics-explained/index.php?oldid=404136>
- [45] United Nations, 'UN Comtrade Database'. 2025. [Online]. Available: <https://comtradeplus.un.org/>



- [46] European Commission, 'Competition Case M.11812 – METHANEX / OCI METHANOL BUSINESS'. May 13, 2025. [Online]. Available: https://ec.europa.eu/competition/mergers/cases1/202514/M_11812_10589896_660_3.pdf
- [47] 'ExxonMobil to Close Scotland Ethylene Plant in 2026 as Europe Exit Deepens', Blooming Trade Data. [Online]. Available: <https://www.bloominglobal.com/media/detail/exxonmobil-to-close-scotland-ethylene-plant-in-2026-as-europe-exit-deepens>
- [48] 'China's cracker expansion to drive LPG storage growth', Argus Media. [Online]. Available: <https://www.argusmedia.com/en/news-and-insights/latest-market-news/2614173-china-s-cracker-expansion-to-drive-lpg-storage-growth>
- [49] 'Project ONE – Better Begins in Antwerp', INEOS Project ONE. [Online]. Available: <https://project-one.ineos.com/en/>
- [50] Dr. M. Hadhri, 'EU27 Chemical Industry: Latest Developments', The European Chemical Industry Council (cefic), AISBL, Brussels, Feb. 2025. [Online]. Available: <https://cefic.org/app/uploads/2025/05/Chemical-Trends-Report-February-2025.pdf>
- [51] 'Evonik trennt sich von Kunststoffbereichen', Kunststoffe. [Online]. Available: <https://www.kunststoffe.de/a/news/evonik-trennt-sich-von-kunststoffbereich-6196950>
- [52] 'BP Europa SE sucht möglichen Käufer für Ruhr Oel GmbH – BP Gelsenkirchen', BP Europa SE. [Online]. Available: https://www.bp.com/de_de/germany/home/presse/pressemeldungen/pm2025-02-06-bp-europa-se-sucht-moeglichen-kaeuer-fuer-rog.html
- [53] 'Shell mulls sale of European, US chemicals assets, WSJ reports', Reuters. [Online]. Available: <https://www.reuters.com/business/energy/shell-mulls-sale-european-us-chemicals-assets-wsj-reports-2025-03-02/>
- [54] B. Pals, 'SABIC verkoopt Europese petrochemie en thermoplastentak, ook fabrieken in Geleen en Bergen op Zoom', Industrielinqs.
- [55] 'Konzernumbau: Shell stellt Treibstoffproduktion in Wesseling ein', WDR. [Online]. Available: <https://www1.wdr.de/nachrichten/rheinland/shell-wesseling-stellt-kein-treibstoff-mehr-her-100.html>
- [56] 'Olin announces epoxy facility closures', European Coatings. [Online]. Available: <https://www.european-coatings.com/news/markets-companies/olin-announces-epoxy-facility-closures/>
- [57] 'Venator Duisburg meldet Insolvenz an – Produktion läuft vorerst weiter', Farbe und Lacke. [Online]. Available: <https://www.farbeundlack.de/nachrichten/markt-branche/venator-duisburg-meldet-insolvenz-an-produktion-laeuft-vorerst-weiter/>
- [58] 'Tronox Announces Intent to Idle its Pigment Plant in the Netherlands', Tronox. [Online]. Available: <https://www.tronox.com/tronox-announces-intent-to-idle-its-pigment-plant-in-the-netherlands/>
- [59] N. Menzel, 'Ineos will zwei Werke in Rheinberg schließen', Chemie Technik. [Online]. Available: <https://www.chemietechnik.de/branche-markt/ineos-will-zwei-werke-in-rheinberg-schliessen/2124313>
- [60] S. Baker, 'Ineos to close world's second largest phenol plant, blaming European energy costs and carbon tax', The Chemical Engineer. [Online]. Available: <https://www.thechemicalengineer.com/news/ineos-to-close-world-s-second-largest-phenol-plant-blaming-european-energy-costs-and-carbon-tax/>
- [61] 'Ineos: Abgestellte PTA-Linie in Belgien steht vor dem endgültigen Aus', Kunststoff Web. [Online]. Available: https://www.kunststoffweb.de/branchen-news/ineos_abgestellte_pta-linie_in_belgien_steht_vor_dem_endgueltigen_aus_t254163
- [62] 'Trinseo Completes Strategic Network Optimization Initiative with Closure of Terneuzen, the Netherlands Styrene Manufacturing Operations', Trinseo. [Online]. Available: <https://investor.trinseo.com/home/news/news-details/2023/Trinseo-Completes-Strategic-Network-Optimization-Initiative-with-Closure-of-Terneuzen-the-Netherlands-Styrene-Manufacturing-Operations/default.aspx>
- [63] 'LyondellBasell (LYB) und Covestro verkünden dauerhafte Schließung der gemeinsamen PO11-Anlage in Maasvlakte, Niederlande', Covestro AG. [Online]. Available: <https://www.covestro.com/press/de/lyondellbasell-lyb-und-covestro-verkueuden-dauerhafte-schliessung-der-gemeinsamen-po11-anlage-in-maasvlakte-niederlande/>
- [64] 'Fibrant to cease caprolactam production at Chemelot, The Netherlands highlighting deepening crisis in European base chemicals', chemXplore. [Online]. Available: <https://chemxplore.com/news/fibrant-to-cess-caprolactam-production-at-chemelot-the-netherlands-highlighting-deepening-crisis-in-european-base-chemicals>
- [65] 'Indorama: PET-Anlagen in Rotterdam stillgelegt', Kunststoff Web. [Online]. Available: https://www.kunststoffweb.de/branchen-news/indorama_pet-anlagen_in_rotterdam_stillgelegt_t255844
- [66] E. Verheggen, 'Vynova sluit PVC-fabriek op Chemelot: "Moeilijke maar noodzakelijke stap"', Industrielinqs. [Online]. Available: https://www.industrielinqs.nl/chemie/2025/07/vynova-sluit-pvc-fabriek-op-chemelot-moeilijke-maar-noodzakelijke-stap/?utm_source=newsletter&utm_medium=email&utm_campaign=Nieuwsbrief%25



- [67] E. Jackson, 'Westlake chemical to shutter Pernis plant amid european downturns'. [Online]. Available: <https://www.chemanalyst.com/NewsAndDeals/NewsDetails/westlake-chemical-to-shutter-pernis-plant-amid-european-downturns-37502>
- [68] 'Plastics Recycling Industry Figures 2024', Plastics Recyclers Europe, Brussels, 2025. [Online]. Available: https://www.plasticsrecyclers.eu/wp-content/uploads/2025/11/Statistics_2025_Final.pdf
- [69] 'Cracker capacity', Petrochemicals Europe. [Online]. Available: <https://www.petrochemistry.eu/about-petrochemistry/petrochemicals-facts-and-figures/cracker-capacity/>
- [70] 'Sabic: Cracker „Olefins 3“ in Geleen wird stillgelegt', Kunststoff Web. [Online]. Available: https://www.kunststoffweb.de/branchen-news/sabic_cracker_olefins_3_in_geleen_wird_stillgelegt_t255065
- [71] A. Sands, 'Sabic mulls future of "crucial" Geleen petchems complex', Argus Media. [Online]. Available: <https://www.argusmedia.com/en/news-and-insights/latest-market-news/2294780-sabic-mulls-future-of-crucial-geleen-petchems-complex>
- [72] M. Thomas, 'Cracker collapse: Capacity rationalization ramps up', Chemweek. [Online]. Available: <https://chemweek.mydigitalpublication.com/articles/cracker-collapse-capacity-rationalization-ramps-up>
- [73] 'Dow to idle one cracker at Terneuzen', Argus Media. [Online]. Available: <https://www.argusmedia.com/en/news-and-insights/latest-market-news/2650907-dow-to-idle-one-cracker-at-terneuzen>
- [74] 'Announcement of closure of LyondellBasell/Covestro (Maasvlakte) and Tronox (Botlek) chemical plants "tough day for the port"', Port of Rotterdam. [Online]. Available: <https://www.portofrotterdam.com/en/news-and-press-releases/announcement-closure-lyondellbasellcovestro-maasvlakte-and-tronox-botlek>
- [75] 'Vioneo drops Antwerp factory plans and opts for China', Belga News Agency. [Online]. Available: <https://www.belganewsagency.eu/vioneo-drops-antwerp-factory-plans-and-opts-for-china>
- [76] A. Scott, 'Key European plastics recycling projects scrapped', C&EN. [Online]. Available: <https://cen.acs.org/environment/recycling/Key-European-plastics-recycling-projects/103/web/2025/08>
- [77] 'Chemical recycler Blue Cycle goes bankrupt in the Netherlands', Plastics infomart. [Online]. Available: <https://www.plasticsinfomart.com/chemical-recycler-blue-cycle-goes-bankrupt-in-the-netherlands/>
- [78] B. MacKenzie, 'Reinvention in Rheinland', Shell. [Online]. Available: <https://www.shell.com/news-and-insights/our-stories/reinvention-in-rheinland.html>
- [79] 'Rotterdam refinery', Neste. [Online]. Available: <https://www.neste.com/about-neste/how-we-operate/production/rotterdam-refinery>
- [80] R. Hoefnagels and S. Germer, 'Supply potential, suitability and status of lignocellulosic feedstocks for advanced biofuels', 2018.
- [81] A. Soler, 'Sustainable biomass availability in the EU towards 2050 (RED II Annex IX, Parts A and B)', 2022.
- [82] J. Moncada, P. Wammes, and M. Jovicic, 'Assessing the Supply Potential of Bio-Based Molecules: A Techno-Economic and Supply Chain Perspective TNO Report', 2025.
- [83] European Commission, 'Development of outlook for the necessary means to build industrial capacity for drop-in advanced biofuels', 2024.
- [84] V. Avitabile *et al.*, 'Biomass production, supply, uses and flows in the European Union', 2023.
- [85] S. B. Mubareka and A. Renner, 'EU Biomass supply, uses, governance and regenerative actions - 10-year anniversary edition', 2025.
- [86] R. A. Jacobson, S. Jones, D. de la T. Ugarte, and K. L. Kline, 'Mapping and Synthesis of International Biomass Supply Assessments', 2025.
- [87] bioenergy KDF, 'International Feedstocks'. Accessed: Nov. 27, 2025. [Online]. Available: https://bioenergykdf.oml.gov/international-feedstocks?f%5B0%5D=feedstock_country%3ANetherlands&page=14
- [88] C. Panoutsou and K. Maniatis, 'Sustainable biomass availability in the EU, to 2050', 2021.
- [89] A. Soler, 'Sustainable biomass availability in the EU towards 2050 (RED II Annex IX, Parts A and B)', 2022.
- [90] CONCAWE, 'A look into the maximum potential availability and demand for low-carbon feedstocks/fuels in Europe (2020-2050) (literature review)', 2019.
- [91] European Commission, 'Research and Innovation perspective of the mid and long-term Potential for Advanced Biofuels in Europe', 2020.
- [92] M. Carus, C. vom Berg, M. Kempen, F. Schier, and J. Tandetzki, 'Is there Enough Biomass to Defossilise the Chemicals and Derived Materials Sector by 2050?', nova-Institut GmbH (Ed.), Hürth, Germany, Feb. 2025. [Online]. Available:



- <https://biconsortium.eu/sites/biconsortium.eu/files/publications/Is%20there%20enough%20biomass%20to%20defossilise%20the%20chemicals%20and%20derived%20materials%20sector%20by%202050.pdf>
- [93] 'Substantiation of data for polymer production and processing in the Netherlands', Conversio Market & Strategy GmbH, Final Report, Apr. 2024. [Online]. Available: https://www.internetconsultatie.nl/nationale_circulaire_plastic_norm/document/12507
- [94] 'Navigating Volumes and Value Chains Towards Circularity: Textiles', Circular Plastics. [Online]. Available: <https://circularplasticsnl.org/en/updates/volumes-textiles/>
- [95] W. So, 'Plastic waste exports from the Netherlands in 2023, by destination'. [Online]. Available: <https://www.statista.com/statistics/1357887/plastic-waste-export-volume-netherlands-destination/>
- [96] 'Stoffstrombild Kunststoffe in Deutschland 2021: Zahlen und Fakten zum Lebensweg von Kunststoffen', Conversio Market & Strategy GmbH, Nov. 2022. [Online]. Available: https://plasticseurope.org/de/wp-content/uploads/sites/3/2022/11/Kurzfassung_Stoffstrombild_2021.pdf
- [97] 'Germany Export Data – 2023 Annual Summary', Basel Action Network. [Online]. Available: <https://www.ban.org/plastic-waste-project-hub/trade-data/germany-export-data-annual-summary>
- [98] Conversio Market & Strategy GmbH, 'Stoffstrombild Kunststoffe in Deutschland 2023: Zahlen und Fakten zum Lebensweg von Kunststoffen', 2022.
- [99] 'The Circular Economy for Plastics – A European Analysis 2024', Plastics Europe AISBL, Mar. 2024. [Online]. Available: <https://plasticseurope.org/knowledge-hub/the-circular-economy-for-plastics-a-european-analysis-2024/>
- [100] 'Plastics Implementation Plan 2020-2025', OVAM. [Online]. Available: <https://ovam-english.vlaanderen.be/en/plastics-implementation-plan-2020-2025-and-the-flemish-plan-for-marine-litter>
- [101] EUR-Lex, 'COMMUNICATION FROM THE COMMISSION TO THE EUROPEAN PARLIAMENT, THE COUNCIL, THE EUROPEAN ECONOMIC AND SOCIAL COMMITTEE AND THE COMMITTEE OF THE REGIONS - Securing our future Europe's 2040 climate target and path to climate neutrality by 2050 building a sustainable, just and prosperous society', European Commission, Strasbourg, SWD(2024) 64, Feb. 2024. [Online]. Available: <https://eur-lex.europa.eu/legal-content/EN/TXT/?uri=CELEX%3A52020SC0953>
- [102] European Commission. Directorate General for Energy. *et al.*, AIDRES, "Advancing industrial decarbonization by assessing the future use of renewable energies in industrial processes": assessment and geo mapping of renewable energy demand for technological paths towards carbon neutrality of EU energy intensive industries: methodology and results in support to the EU industrial plants database. LU: Publications Office, 2023. doi: 10.2833/696697.
- [103] M. Yugo, 'Transition towards Low Carbon Fuels by 2050: Scenario analysis for the European refining sector', Concawe, Brussels, Report 7/21, Aug. 2021. [Online]. Available: https://www.concawe.eu/wp-content/uploads/Rpt_21-7.pdf
- [104] European Union, 'AIDRES Dataset'. 2025. [Online]. Available: <https://jeodpp.jrc.ec.europa.eu/ftp/jrc-opendata/EIGL-Data/AIDRES/>
- [105] 'The European Hydrogen Backbone (EHB) initiative', European Hydrogen Backbone. [Online]. Available: <https://ehb.eu/>
- [106] ENTSOG, EUROGAS, GIE, GEODE, GD4S, and CEDEC, 'Hydrogen Infrastructure Map'. Accessed: Nov. 01, 2024. [Online]. Available: <https://www.h2inframap.eu/>
- [107] 'Study on large-scale import of hydrogen from other continents – Hydrogen Import Coalition', WaterstofNet. [Online]. Available: <https://www.waterstofnet.eu/en/knowledge-centre/roadmaps-and-studies/h2-importcoalition>
- [108] 'The Trilate Project – Research', Trilate. [Online]. Available: <https://trilate.eu/en/research>
- [109] EUR-Lex, 'COMMUNICATION FROM THE COMMISSION TO THE EUROPEAN PARLIAMENT, THE COUNCIL, THE EUROPEAN ECONOMIC AND SOCIAL COMMITTEE AND THE COMMITTEE OF THE REGIONS – Towards an ambitious Industrial Carbon Management for the EU', European Commission. [Online]. Available: <https://eur-lex.europa.eu/legal-content/EN/TXT/?uri=COM%3A2024%3A62%3AFIN&qid=1707312980822>
- [110] 'Scigrid database'. [Online]. Available: https://www.gas.scigrid.de/posts/2020-Sep-02_iggielgn.html
- [111] E. S. Rubin, J. E. Davison, and H. J. Herzog, 'The cost of CO₂ capture and storage', *International Journal of Greenhouse Gas Control*, vol. 40, pp. 378–400, Sep. 2015, doi: 10.1016/j.ijggc.2015.05.018.
- [112] 'Technology Data for Carbon Capture, Transport and Storage', The Danish Energy Agency. Accessed: May 24, 2024. [Online]. Available: <https://ens.dk/en/our-services/technology-catalogues/technology-data-carbon-capture-transport-and-storage>
- [113] 'Building the Cost Curves for CO₂ Storage: European Sector', IEAGHG, Technical Report 2005–02, Feb. 2005. [Online]. Available: <https://ieaghg.org/publications/building-the-cost-curves-for-co2-storage-european-sector/>



- [114] European Commission, 'EU sets world's first voluntary standard for permanent carbon removals', European Commission. Energy, Climate change, Environment. Accessed: Mar. 18, 2026. [Online]. Available: https://climate.ec.europa.eu/news-other-reads/news/eu-sets-worlds-first-voluntary-standard-permanent-carbon-removals-2026-02-03_en
- [115] 'FORBEG – A European comparison of electricity and natural gas prices for residential, small professional and large industrial consumers', PwC, May 2025. [Online]. Available: <https://www.creg.be/sites/default/files/assets/Publications/Studies/F20250514EN.pdf>
- [116] 'Natural Gas Prices', U.S. Energy Information Administration. [Online]. Available: https://www.eia.gov/dnav/ng/ng_pri_sum_a_EPG0_PIN_DMcf_a.htm
- [117] 'China gas price', CEIC Data. [Online]. Available: <https://www.ceicdata.com/en/china/gas-price-36-city>
- [118] 'China Industrial Production: Ethylene: By Region', CEIC Data. [Online]. Available: <https://www.ceicdata.com/en/china/industrial-production-ethylene-by-region>
- [119] Deloitte, 'Benchmarking study of electricity prices between Belgium and neighbouring countries', Febeliec – Federation of Belgian Industrial Energy Consumers, 2025. [Online]. Available: https://www.febeliec.be/web/deloitte%20studie%20elektriciteitsprijzen%20_%20update%202022%20_24_04_2022_/1011306065/list1187970135/f1.html
- [120] 'China Electricity Price: 36 City', CEIC Data. [Online]. Available: <https://www.ceicdata.com/en/china/electricity-price-36-city>
- [121] U.S. Energy Information Administration, '2024 Utility Bundled Retail Sales- Industrial'. 2024. [Online]. Available: https://www.eia.gov/electricity/sales_revenue_price/pdf/table_8.pdf
- [122] U.S. Energy Information Administration, 'Electricity – Electric Sales, Revenue, and Average Price'. Oct. 07, 2025. [Online]. Available: https://www.eia.gov/electricity/sales_revenue_price/
- [123] 'Ethane Storage and Distribution Hub in the United States', U.S. Department of Energy, Washington DC, Report to Congress, Nov. 2018. [Online]. Available: <https://www.energy.gov/hgeo/articles/november-2018-ethane-storage-and-distribution-hub-united-states>
- [124] 'China Crude Oil Import and Export Price', CEIC Data. [Online]. Available: <https://www.ceicdata.com/en/china/crude-oil-import-and-export-price>
- [125] J. Young, 'U.S. ethane production, consumption, and exports set new records in 2024', U.S. Energy information Administration. [Online]. Available: <https://www.eia.gov/todayinenergy/detail.php?id=64785#>
- [126] 'Monthly Densified Biomass Fuel Report', U.S. Energy information Administration. [Online]. Available: <https://www.eia.gov/biofuels/biomass/>
- [127] E. Curcio, 'Techno-economic analysis of hydrogen production: Costs, policies, and scalability in the transition to net-zero', *International Journal of Hydrogen Energy*, vol. 128, pp. 473–487, May 2025, doi: 10.1016/j.ijhydene.2025.04.013.
- [128] I. Yin, 'China has established 125,000 mt/year of green hydrogen production capacity: NEA', S&P Global. [Online]. Available: <https://www.spglobal.com/energy/en/news-research/latest-news/energy-transition/043025-china-has-established-125000-mtyear-of-green-hydrogen-production-capacity-nea>
- [129] 'Global Hydrogen Review 2025', International Energy Agency IEA, Oct. 2025. [Online]. Available: <https://iea.blob.core.windows.net/assets/a6c466dd-b6f0-44bd-a60a-6940eccfb1c3/GlobalHydrogenReview2025.pdf>
- [130] L. Pingkuo and G. Junqing, 'Comparative analysis on the development potential of green hydrogen industry in China, the United States and the European Union', *International Journal of Hydrogen Energy*, vol. 84, pp. 700–717, Sep. 2024, doi: 10.1016/j.ijhydene.2024.08.298.
- [131] Tradingeconomics, 'EU Carbon Permits'. [Online]. Available: <https://tradingeconomics.com/commodity/carbon>
- [132] 'Rewrite Green For Tomorrow', MVGX. [Online]. Available: <https://www.mvgx.com/#/>
- [133] 'Book & Claim in der Logistik – Neue Spielregeln für Emissionsbilanzierung & ESG-Reporting', DFGE Certania Group. [Online]. Available: <https://dfge.de/book-claim-in-der-logistik-neue-spielregeln-fuer-emissionsbilanzierung-esg-reporting/>
- [134] J. F. P. Cornette and J. Blondeau, 'The costs of hydrogen and conventional energy carriers: temporal evolutions and mutual price correlations – global insights with a focus on Belgium', *International Journal of Sustainable Energy*, vol. 43, no. 1, p. 2422915, Dec. 2024, doi: 10.1080/14786451.2024.2422915.
- [135] C. Bang, A. Vitina, J. S. Gregg, and H. H. Lindboe, 'Analysis of biomass prices – FUTURE DANISH PRICES FOR STRAW, WOOD CHIPS AND WOOD PELLETS "FINAL REPORT"', Ea Energy Analyses, Copenhagen, DK, Final Report, Jun. 2013. [Online]. Available: https://www.ea-energianalyse.dk/wp-content/uploads/2020/02/1280_analysis_of_biomass_prices.pdf
- [136] 'Tools for biomass chains', S2Biom. [Online]. Available: <https://s2biom.wenr.wur.nl/biomass-cost-supply-imports>



- [137] 'Naphtha, CIF - NW Europe (01 Aug 2024 - 31 Jul 2025)', Fibre2Fashion. [Online]. Available: https://www.fibre2fashion.com/market-intelligence/texpro-textile-and-apparel/raw-material-prices/naphtha/products/nw-europe?utm_source=chatgpt.com
- [138] eurostat, 'Recycling – secondary material price indicator'. Mar. 2025. [Online]. Available: <https://ec.europa.eu/eurostat/statistics-explained/index.php?oldid=672487>
- [139] Procurement Resource, 'Pyrolysis Oil Price Trend and Forecast', Procurement Resource. Accessed: Mar. 18, 2026. [Online]. Available: <https://www.procurementresource.com/resource-center/pyrolysis-oil-price-trends>
- [140] G. Mehta, 'Pyrolysis Oil Prices: 2025 Trends, Regional Insights, and Market Outlook'. Accessed: Mar. 18, 2026. [Online]. Available: <https://www.linkedin.com/pulse/pyrolysis-oil-prices-2025-trends-regional-insights-market-mehta-t8zkc>
- [141] T. Kuramochi, A. Ramírez, W. Turkenburg, and A. Faaij, 'Comparative assessment of CO₂ capture technologies for carbon-intensive industrial processes', *Progress in Energy and Combustion Science*, vol. 38, no. 1, pp. 87–112, Feb. 2012, doi: 10.1016/j.pecs.2011.05.001.
- [142] 'Global bio-based Naphtha Market Forecast 2023-2032', Inkwood Research. [Online]. Available: https://www.inkwoodresearch.com/reports/bio-based-naphtha-market/?srsltid=AfmBOopIBevZ4ggfoEP8_4s5645Mxl-UJdKo4cknIn0BbLDDuS9TjSX
- [143] 'Ethane Prices Worldwide', Intratec Solutions. [Online]. Available: <https://www.intratec.us/solutions/primary-commodity-prices/commodity/ethane-prices>
- [144] M. Al-Breiki and Y. Bicer, 'Comparative cost assessment of sustainable energy carriers produced from natural gas accounting for boil-off gas and social cost of carbon', *Energy Reports*, vol. 6, pp. 1897–1909, Nov. 2020, doi: 10.1016/j.egy.2020.07.013.
- [145] ENTSOG and ENTSOE, 'TYNDP 2024 Scenarios Report', Jan. 2025. [Online]. Available: <https://2024.entsos-tyndp-scenarios.eu/download/>
- [146] J. Correa-Laguna and J. Valee, 'ETF- PROCURA project WP3, final report', EnergyVille - VITO, Aug. 2025. doi: 10.5281/ZENODO.16876276.
- [147] S. Giuseppe, K. Vlaeminck, F. Van Nuffel, L. Hanegreefs, M. Peeters, and I. François, 'Belgium as a hydrogen import hub. Roadmap towards 2030 and beyond', Oct. 2023. [Online]. Available: https://www.waterstofnet.eu/_asset/_public/H2Importcoalitie/Belgium-as-a-hydrogen-importhub_web_singlepage-presentation.pdf
- [148] EnergyVille, 'PATHS 2050 | The Power of Perspective', Perspective 2050. [Online]. Available: <https://perspective2050.energyville.be/paths2050>
- [149] A. Pluta *et al.*, 'SciGRID_gas - Data Model of the European Gas Transport Network', in *2022 Open Source Modelling and Simulation of Energy Systems (OSMSES)*, Aachen, Germany: IEEE, Apr. 2022, pp. 1–7. doi: 10.1109/OSMSES54027.2022.9769122.
- [150] 'Hydrogen network Netherlands', Hynetwork. [Online]. Available: <https://www.hynetwork.nl/en/about-hynetwork/hydrogen-network-netherlands>
- [151] FNB-Gas, 'Wasserstoff-Kernnetz', FNB-Gas. [Online]. Available: <https://fnb-gas.de/wasserstofftransport/wasserstoff-kernnetz/>
- [152] 'Waterstof: Voorbereidingen om het netwerk te bouwen', Fluxys. [Online]. Available: <https://www.fluxys.com/nl/projects/hydrogen-preparing-to-build-the-network>
- [153] N. Namazifard, P. Vingerhoets, and E. Delarue, 'Long-term cost optimization of a national low-carbon hydrogen infrastructure for industrial decarbonization', *International Journal of Hydrogen Energy*, vol. 64, pp. 583–598, Apr. 2024, doi: 10.1016/j.ijhydene.2024.02.324.
- [154] The Danish Energy Agency, 'Technology Data for Generation of Electricity and District Heating'. [Online]. Available: <https://ens.dk/en/analyses-and-statistics/technology-data-generation-electricity-and-district-heating>
- [155] EUR-Lex, 'COMMISSION STAFF WORKING DOCUMENT Clean Energy Transition – Technologies and Innovations Accompanying the document REPORT FROM THE COMMISSION TO THE EUROPEAN PARLIAMENT AND THE COUNCIL on progress of clean energy competitiveness', European Commission, Brussels, Oct. 2020. [Online]. Available: <https://eur-lex.europa.eu/legal-content/EN/TXT/?uri=CELEX%3A52020SC0953>
- [156] '2024 Electricity ATB Technologies and Data Overview', Annual Technology Baseline. Accessed: Mar. 18, 2026. [Online]. Available: <https://atb.nrel.gov/electricity/2024/index>
- [157] IEA, 'Global Energy and Climate Model key input data'. Nov. 2025. [Online]. Available: <https://www.iea.org/data-and-statistics/data-product/global-energy-and-climate-model-key-input-data>



- [158] 'EU Reference Scenario 2020', European Commission. [Online]. Available: https://energy.ec.europa.eu/data-and-analysis/energy-modelling/eu-reference-scenario-2020_en
- [159] S. Krishnan *et al.*, 'Present and future cost of alkaline and PEM electrolyser stacks', *International Journal of Hydrogen Energy*, vol. 48, no. 83, pp. 32313–32330, Oct. 2023, doi: 10.1016/j.ijhydene.2023.05.031.
- [160] M. van E. Z. en Klimaat, 'Evaluation of the levelised cost of hydrogen based on proposed electrolyser projects in the Netherlands - Rapport - Rijksoverheid.nl'. Accessed: Jan. 23, 2025. [Online]. Available: <https://www.rijksoverheid.nl/documenten/rapporten/2024/05/30/bijlage-1-tno-2024-r10766-evaluation-of-the-levelised-cost-of-hydrogen-based-on-proposed-electrolyser-projects-in-the-netherlands-definitief>
- [161] The Danish Energy Agency, 'Technology Data for Energy Storage'. [Online]. Available: <https://ens.dk/en/analyses-and-statistics/technology-data-energy-storage>
- [162] European Commission, 'The role of renewable H₂ import & storage to scale up the EU deployment of renewable H₂', European Commission, Feb. 2022. [Online]. Available: <https://data.europa.eu/doi/10.2833/727785>
- [163] European Hydrogen Backbone, 'EHB publications', EHB European Hydrogen Backbone. Accessed: Jan. 29, 2025. [Online]. Available: <https://www.ehb.eu/page/publications>
- [164] F. Yang, H. Meerman, Z. Zhang, J. Jiang, and A. Faaij, 'Integral techno-economic comparison and greenhouse gas balances of different production routes of aromatics from biomass with CO₂ capture', *Journal of Cleaner Production*, vol. 372, no. July, 2022, doi: 10.1016/j.jclepro.2022.133727.
- [165] A. Uslu, J. Moncada, and C. Oliveira, 'Demand for Renewable Hydrocarbons in 2030 and 2050', 2020.
- [166] J. T. Manalal, M. Pérez-Fortes, and A. Ramírez, 'Re-wiring petrochemical clusters: impact of using alternative carbon sources for ethylene production', *Green Chemistry*, vol. 27, no. 22, pp. 6641–6659, 2025, doi: 10.1039/D4GC06042C.
- [167] F. K. Kazi *et al.*, 'Techno-Economic Analysis of Biochemical Scenarios for Production of Cellulosic Ethanol', 2010.
- [168] P. Haro, P. Ollero, and F. Trippe, 'Technoeconomic assessment of potential processes for bio-ethylene production', *Fuel Processing Technology*, vol. 114, pp. 35–48, 2013, doi: <https://doi.org/10.1016/j.fuproc.2013.03.024>.
- [169] M. M. Wright, J. A. Satrio, R. C. Brown, D. E. Dugaard, and D. D. Hsu, 'Techno-economic analysis of biomass fast pyrolysis to transportation fuels. Technical Report NREL/TP-6A20-46586', 2010.
- [170] M. Sharifzadeh, L. Wang, and N. Shah, 'Decarbonisation of olefin processes using biomass pyrolysis oil', *Applied Energy*, vol. 149, pp. 404–414, 2015, doi: 10.1016/j.apenergy.2015.03.081.
- [171] E. C. D. Tan and L. Tao, 'Economic Analysis of Renewable Fuels for Marine Propulsion', 2019.
- [172] I. C. ten Have and B. M. Weckhuysen, 'The active phase in cobalt-based Fischer-Tropsch synthesis', *Chem Catalysis*, vol. 1, no. 2, pp. 339–363, Jul. 2021, doi: 10.1016/j.checat.2021.05.011.
- [173] Y. Cheng *et al.*, 'Fischer–Tropsch Synthesis to Lower Olefins over Potassium-Promoted Reduced Graphene Oxide Supported Iron Catalysts', *ACS Catalysis*, vol. 6, no. 1, pp. 389–399, 2016, doi: <https://doi.org/10.1021/acscatal.5b02024>.
- [174] M. Oschatz, W. S. Lamme, J. Xie, A. I. Dugulan, and K. P. de Jong, 'Ordered Mesoporous Materials as Supports for Stable Iron Catalysts in the Fischer–Tropsch Synthesis of Lower Olefins', *ChemCatChem*, vol. 8, no. 17, pp. 2846–2852, 2016, doi: 10.1002/cctc.201600492.
- [175] E. Ø. Pedersen, I. H. Svenum, and E. A. Blekkan, 'Mn promoted Co catalysts for Fischer-Tropsch production of light olefins – An experimental and theoretical study', *Journal of Catalysis*, vol. 361, pp. 23–32, 2018, doi: 10.1016/j.jcat.2018.02.011.
- [176] Y. Gao *et al.*, 'Recent advances in iron-based catalysts for Fischer–Tropsch to olefins reaction', *Catalysis Communications*, vol. 181, no. April, p. 106720, 2023, doi: 10.1016/j.catcom.2023.106720.
- [177] European Commission, 'Renewable Energy – Recast to 2030 (RED II)'. Accessed: Nov. 27, 2025. [Online]. Available: https://joint-research-centre.ec.europa.eu/welcome-jec-website/reference-regulatory-framework/renewable-energy-recast-2030-red-ii_en
- [178] Ministry of Infrastructure & Water Management, 'Biofuels in relation to food and feed crops', 2025.
- [179] IEA Bioenergy, 'Biofuels production and development in the European Union'. Accessed: Jul. 09, 2025. [Online]. Available: <https://www.ieabioenergy.com/blog/publications/biofuels-production-and-development-in-the-european-union/>
- [180] European Court of Auditors, 'The EU's support for sustainable biofuels in transport', 2023.
- [181] J. Sihvonen, 'The trend worsens: More palm oil for energy, less for food', 2019.
- [182] ICIS, 'Insights: EU regulatory certainty needed to boost bio-naphtha and pyrolysis oil growth'. Accessed: Nov. 27, 2025. [Online]. Available: <https://www.icis.com/explore/resources/news/2025/07/02/11116111/insight-eu-regulatory-certainty-needed-to-boost-bio-naphtha-and-pyrolysis-oil-growth/>



- [183] 'Renewable Energy – Recast to 2030 (RED II)', European Commission. [Online]. Available: https://joint-research-centre.ec.europa.eu/welcome-jec-website/reference-regulatory-framework/renewable-energy-recast-2030-red-ii_en
- [184] M. Carus, O. Porc, C. vom Berg, M. Kempen, F. Schier, and J. Tandetzki, 'Is there Enough Biomass to Defossilise the Chemicals and Derived Materials Sector by 2050? – A Joint BIC and RCI Scientific Background Report', Feb. 2025. doi: 10.52548/PIRL6916.
- [185] Renewable Carbon Initiative (RCI), 'EU and Global : Biomass Demand for Transport Fuels , Aviation and Shipping up to 2050 and Implications for Biomass Supply to the Chemical Sector', 2025.
- [186] Cefic, 'The carbon managers', 2024.
- [187] M. Broeren, M. Uittewaal, and G. Bergsma, 'Monitoring Chemical Recycling. How to include chemical recycling in plastic recycling monitoring?', CE Delft, Delft, Mar. 2022. [Online]. Available: https://ce.nl/wp-content/uploads/2022/04/CE_Delft_210126_Monitoring_Chemical_Recycling_Def.pdf
- [188] Netherlands Institute for Sustainable Packaging (KIDV), 'Chemical recycling of plastic packaging materials', 2018.
- [189] J. T. Manalal, M. Pérez-Fortes, and A. Ramírez, 'Re-wiring petrochemical clusters: impact of using alternative carbon sources for ethylene production', *Green Chem.*, vol. 27, no. 22, pp. 6641–6659, 2025, doi: 10.1039/D4GC06042C.
- [190] H. Zimmermann and R. Walzl, 'Ethylene', in *Ullmann's Encyclopedia of Industrial Chemistry*, vol. 4, Weinheim, Germany: Wiley-VCH Verlag GmbH & Co. KGaA, 2009, pp. 473–482. doi: 10.1002/14356007.a10_045.pub3.
- [191] J. Jiang, X. Feng, M. Yang, and Y. Wang, 'Comparative technoeconomic analysis and life cycle assessment of aromatics production from methanol and naphtha', *Journal of Cleaner Production*, vol. 277, p. 123525, Dec. 2020, doi: 10.1016/j.jclepro.2020.123525.
- [192] F. Güleş, J. A. Okolie, and A. Erdogan, 'Techno-economic feasibility of fluid catalytic cracking unit integrated chemical looping combustion – A novel approach for CO₂ capture', *Energy*, vol. 284, no. August, p. 128663, Dec. 2023, doi: 10.1016/j.energy.2023.128663.
- [193] B. Ciuffi, D. Chiaramonti, A. M. Rizzo, M. Frediani, and L. Rosi, 'A Critical Review of SCWG in the Context of Available Gasification Technologies for Plastic Waste', *Applied Sciences*, vol. 10, no. 18, p. 6307, Sep. 2020, doi: 10.3390/app10186307.
- [194] Conversio, 'Substantiation of data for polymer production and processing in the Netherlands', 2024.
- [195] Circular Plastics NL, 'Circular Plastics NL - Navigating Volumes and Value Chains Towards Circularity', 2025.
- [196] 'Plastic waste exports from the Netherlands in 2023, by destination', Statista. Accessed: May 26, 2025. [Online]. Available: <https://www.statista.com/statistics/1357887/plastic-waste-export-volume-netherlands-destination/>
- [197] M. de Leeuw and R. Koelemeijer, 'Decarbonisation options for the Dutch waste incineration industry.', 2022.
- [198] 'Plastic use and plastic waste processing in the Netherlands', CE Delft. Accessed: May 26, 2025. [Online]. Available: <https://cedelft.eu/publications/plastic-use-and-plastic-waste-processing-in-the-netherlands/>
- [199] Basel action network, 'Germany Export Data'. Accessed: Jun. 06, 2025. [Online]. Available: <https://www.ban.org/plastic-waste-project-hub/trade-data/germany-export-data-annual-summary>
- [200] 'The Antwerp Declaration for a European Industrial Deal', The Antwerp Declaration for a European Industrial Deal. [Online]. Available: <https://antwerp-declaration.eu/>

Annex A. Current status and methodology

Value chains

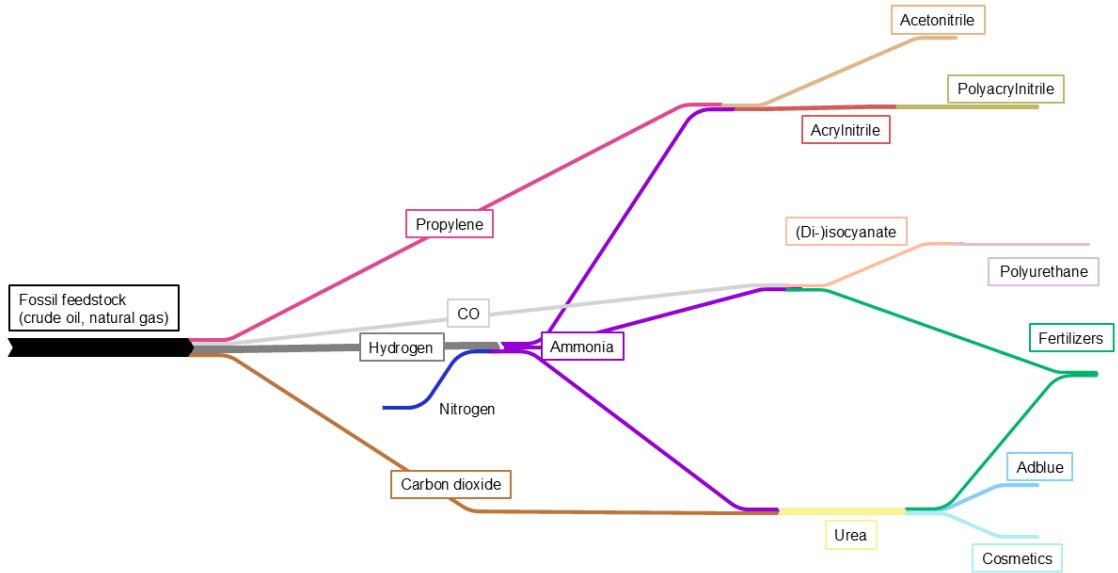

Figure 44. Ammonia value chain.

Production data

Table 4. Steam cracker production capacities in Europe in the end of 2024 and January 2026.

Region	Nameplate capacity end of 2024, kt _{ethylene/a}	Nameplate capacity January 2026, kt _{ethylene/a}	Source
The Netherlands	3,495	2,930	[69], [internal database, DEC]
Flanders	2,240	2,240	[69], [internal database, DEC]
North Rhine-Westphalia	3,578	3,578	[69], [internal database, DEC]
TCR, total	9,313	8,748	[69], [internal database, DEC]
Germany	5,723	5,723	[69], [internal database, DEC]
EU27+3 (Norway, Switzerland, United Kingdom)	22,466	20,931	[69], [internal database, DEC]

Table 5. Share of the TCR's production volumes of selected commodities in the overall production of the EU27. Based on [26], [27].

Commodity	EU27, kt	Netherlands, %	Belgium, %	NRW, %
Ethylene	11,641	13		
Propylene	10,041	12	8	
Benzene	5,054	19	12	15
Toluene	1,083		22	37
LLDPE	2,140	8		
LDPE	3,160		20	
HDPE	5,445	6	19	17
PP	8,751	8	23	10

Only commodities are presented for which production volumes for Netherlands, Flanders or NRW were available in the official statistics.

Table 6. Total production of selected commodities in Germany and NRW. Based on [26], [27].

Commodity	Year	Germany, kt	NRW, kt	Share of NRW %
Propylene	2019	3,439	1,784	52
Benzene	2024	1,260	754	60
Toluene	2024	567	399	70
HDPE	2024	1,615	915	57
PP	2024	1,652	869	53

Only commodities are presented for which both production volumes on Germany and NRW were available in the official statistics.

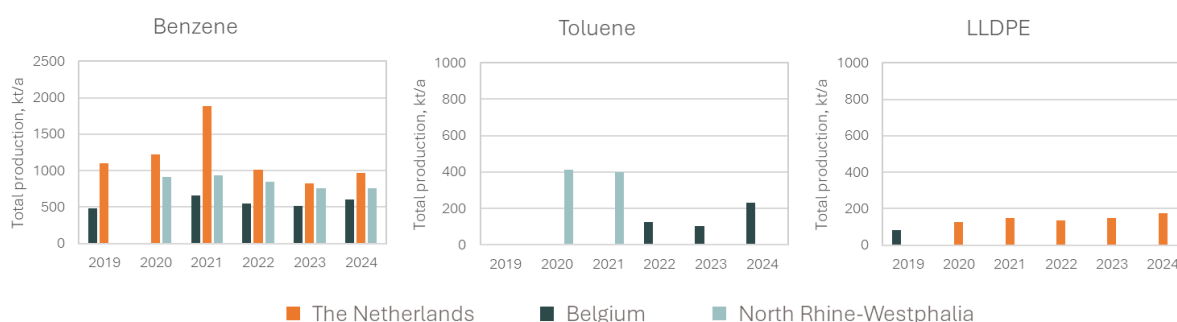

Figure 45. Total production volumes of selected commodities in the TCR from 2019 to 2024. Based on available statistical data from [26], [27].

Table 7. Export-to-domestic consumption ratio for the analysed commodities in the TCR.

	Export-to-domestic-consumption ratio (EDCR)		
	The Netherlands	Belgium	NRW
Ethylene	1.2	n.a.	n.a.
Propylene	1.0	0.1	n.a.
Benzene	4.0	0.3	0.5*
Toluene	n.a.	1.2	n.a.
HDPE	6.5	0.9	0.6*
PP	0.4	0.3	0.5*

$$EDCR = \frac{\text{Exports}}{\text{Domestic Consumption}} = \frac{\text{Exports}}{\text{Imports} + \text{Production} - \text{Exports}}$$

Not possible to calculate precisely for NRW since the trade flow for Germany is not known. Only commodities are presented for which both production volumes and trade data were available in the official statistics.

Net trade flows

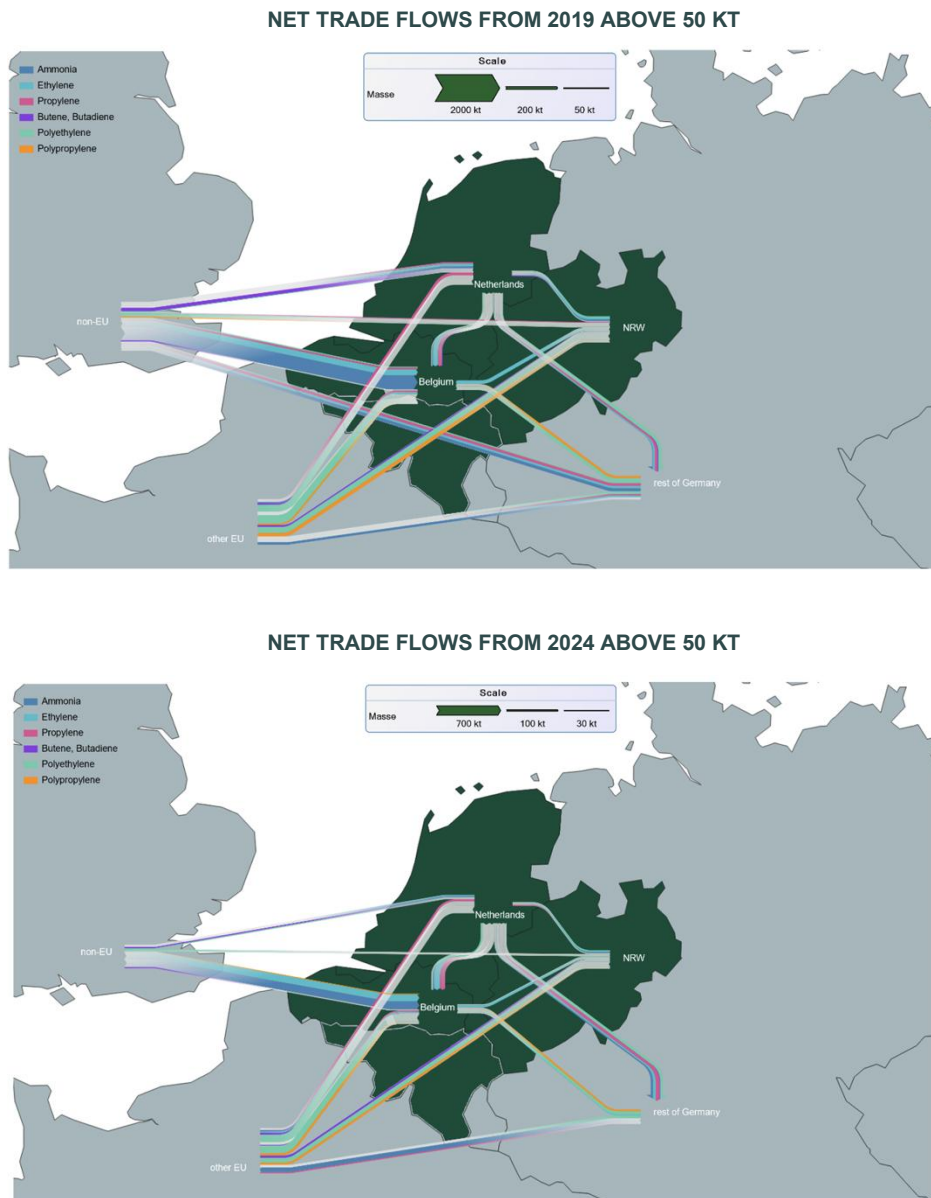

Figure 46. Net trade flows analysis: flows between the TCR countries and the rest of the world as of 2019 (above) and 2024 (below). Trade flows include ammonia, the steam cracker products ethylene, propylene, butene and butadiene, the polymers polyethylene and polypropylene. Only net trade flows above 50 kt are displayed. The colour of an arrow gets more intense towards its destination to indicate the direction of the respective flow. Trade flow of NRW-DE is not included due to the limited publicly available data.

Trade partners

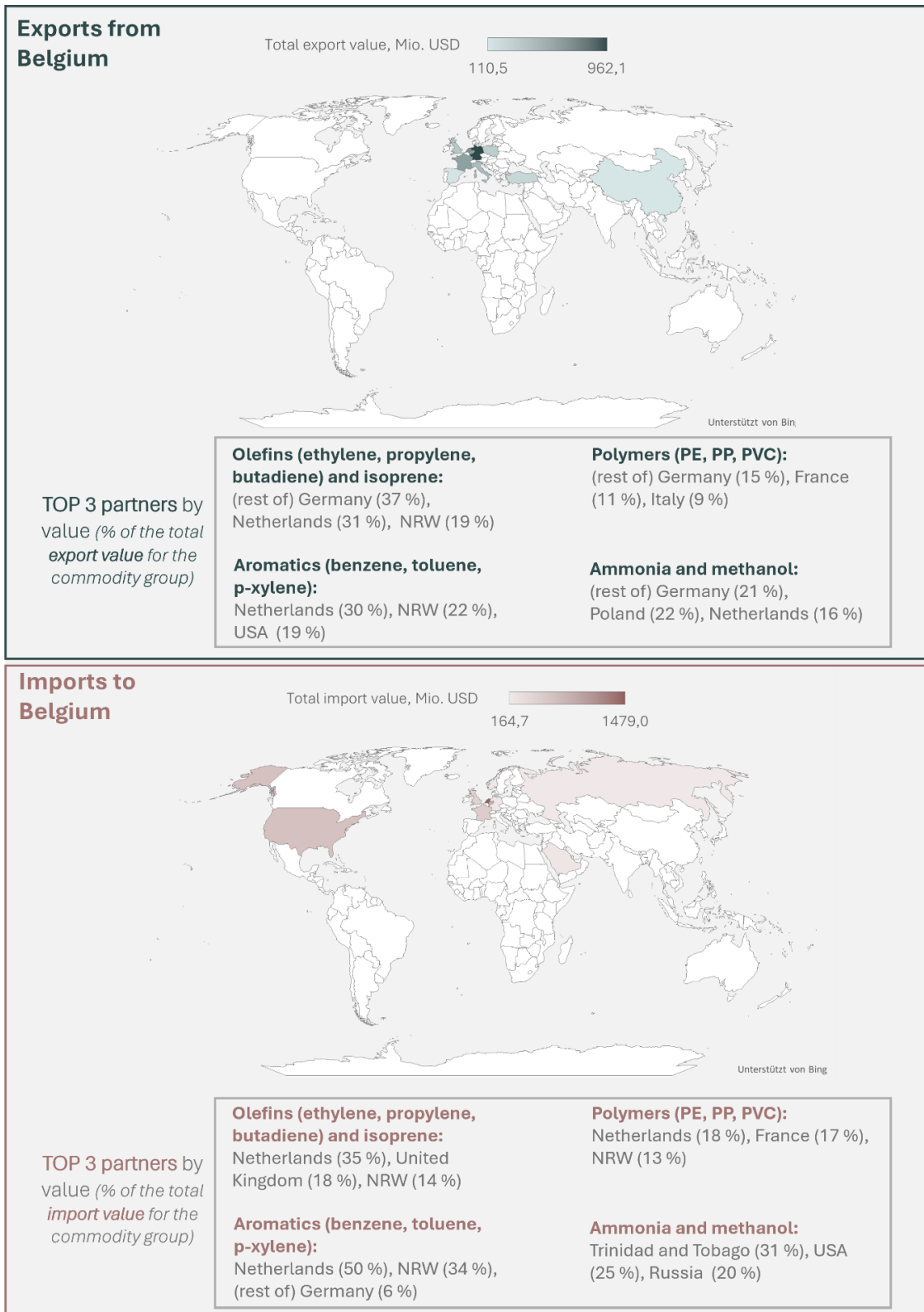

Figure 47. Ten main import and export partners of Belgium in 2024 for the analysed commodities. Based on the data from [33].

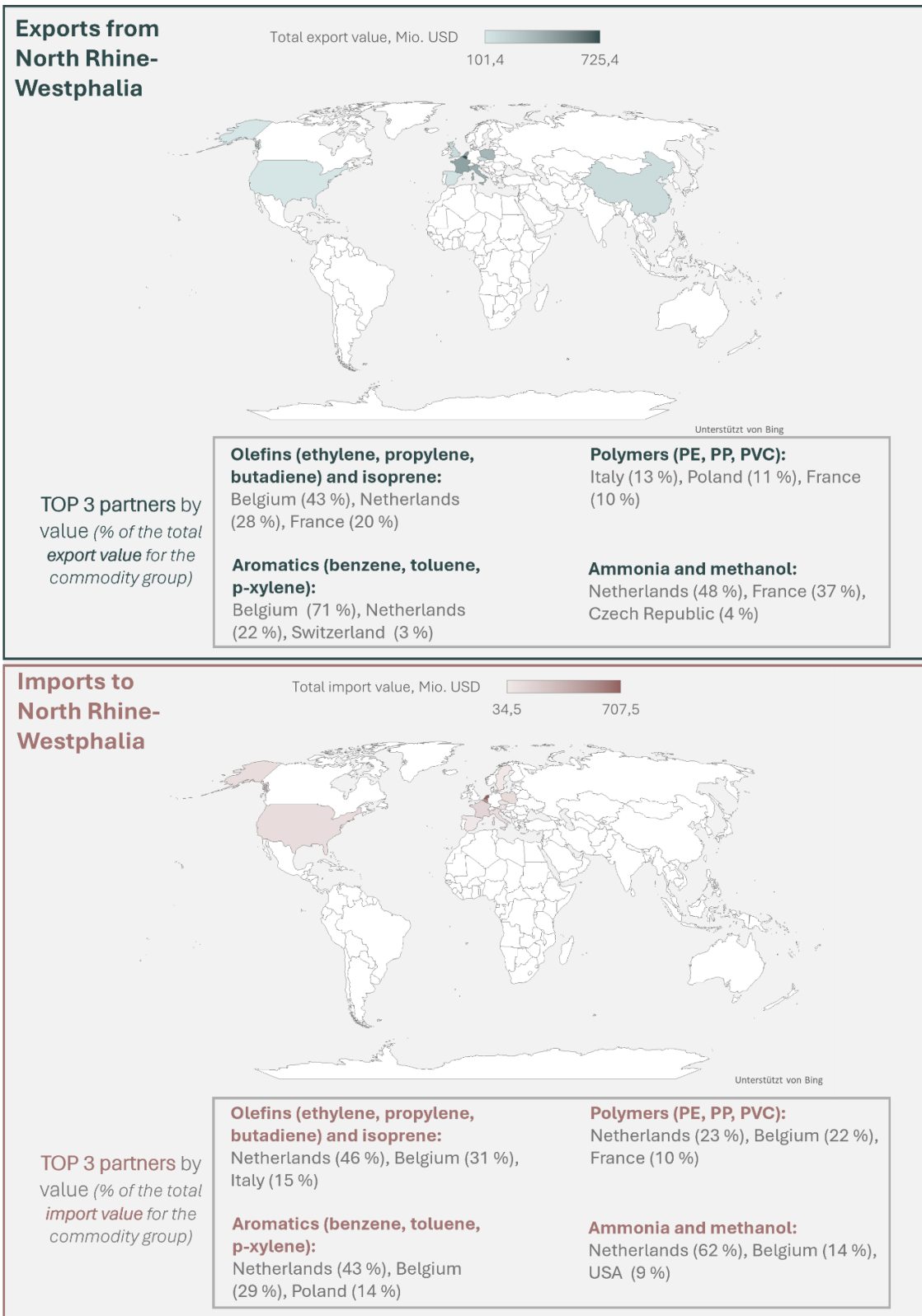

Figure 48. Ten main import and export partners of North Rhine-Westphalia in 2024 for the analysed commodities. Based on the data from [33]. Trade flows from and to the rest of Germany are not available in international trade statistics and not shown here but expected to be significant.

Methodology

- **Company interviews**

An active exchange with industry stakeholders was an essential part of the project. Stakeholder engagement included two workshops on SWOT analysis and policies, several online presentations of intermediate results, and company interviews. Twenty-four companies located in the TCR were interviewed.

The stakeholder exchange was organised with the active support of the regional industry (VCI NRW, essencia and VNCI).

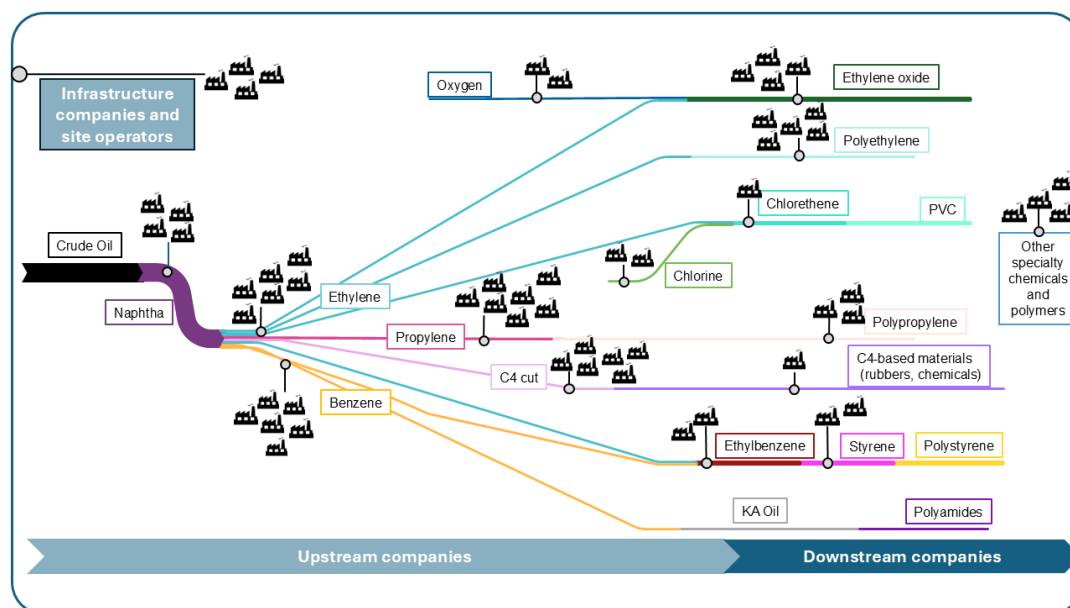

Figure 49. Distribution of the interviewed companies along the steam cracker value chain.

- **SWOT Analysis**

The SWOT (Strengths, Weaknesses, Opportunities, Threats) analysis is a powerful tool for strategic planning and business analysis. The SWOT framework facilitates the identification of internal and external factors which may contribute to an organisation's relative advantages or disadvantages. By correlating internal vs. external factors, it enables the development of strategies to tackle/solve specific issues.

For the 3C-VaCS stakeholder workshop, we defined the chemical industry in the TCR as the organisation, whereas factors typical for the region such as high infrastructure density and innovative environment were considered internal. We collected SWOT factors based on the evaluation of bilateral company interviews prior to the workshop, with the opportunity for the participants to modify and add factors. The agenda was structured as follows:

Ballot paper handouts were distributed among the stakeholders, who were asked to vote for up to three, according to their opinion most important factors. The counts were summarised and the most-rated SWOTs were selected for the next step.

Matrices confronting internal vs. external factors were generated and used by groups of participants to discuss and decide to what extent each internal factor contributes to the occurrence of a correlating external factor. As a result, each combination of factors was assigned a count for either low (1), medium (2) or high (3) extent. A scheme of such a matrix is given in Table 8.

Table 8. Confrontation matrix for evaluating the correlation of internal and external factors.

		Strengths			Weaknesses		
		1	2	3	1	2	3
Opportunities	1	To what extent does the strength help us take advantage of the opportunity?			To what extent does the weakness prevent us from exploiting the opportunity?		
	2						
	3						
Threats	1	To what extent does the strength help us fend off the threat?			To what extent does the weakness prevent us from fending off the threat?		
	2						
	3						

Those combinations of factors with the highest correlation were used in the last step to develop specific strategies on how one can



- a. use a strength to take advantage of an opportunity
- b. overcome a weakness that prevents us from taking advantage of an opportunity
- c. use a strength to reduce the likelihood and impact of a threat
- d. overcome a weakness that will make a threat a reality

To guide the strategy development and in order to receive a structured output, we designed handouts in which the group should define concrete actions/steps that need to be taken by a certain assigned party (i. e. policy makers, associations or industry) at a certain point on a timeline, in order to accomplish the goal of the strategy. The strategy should then be summarised in 1-2 sentences. An example is shown in Figure 50.

Security of Supply
How do I use my **strength** to take advantage of the **opportunity**?

Strength: Pipeline infrastructure
Opportunity: Repurposing of the existing infrastructure

Comments from the final discussion:

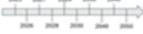
What should be done?	Who should act?	Required resources (high/medium/low amount)	Timeline for the action	Comments
				
				
				
				

Strategy:



Figure 50. Handout for the SWOT strategy development.



At the end of the workshop, the handouts with the developed strategies were pinned to poster walls and the participants voted for their favourite strategies using stickers.

By its very nature, the SWOT framework prioritises those pairs of internal and external factors that are most interconnected. Consequently, the developed strategies are the ones most likely to be derived, as their external factors are most strongly influenced by the corresponding internal factors. Due to time constraints, only up to four of the highest-correlating factor pairs per field of action were subjected to the strategy development. It is therefore important to note that other highly relevant issues may have been excluded earlier simply because they are less likely to be addressed using the resources available within the chemical industry in the TCR.

- **Trade partners**

On the maps (Figure 13, Figure 47, Figure 48), **ten countries** with the highest total export or import value (in USD) for the selected region in 2024 are shown. The total export/import values were calculated as a sum over all analysed commodities are shown. These commodities are the ones in the focus of the study:

- Olefins: ethylene, propylene, butadiene;
- Polymers: polyethylene (LDPE, HDPE), polypropylene;
- Other base chemicals: ammonia, methanol.

For trade flows between Belgium, the Netherlands, and Germany, the trade data reported by Germany were used to allow a distinct separation of flows to and from North Rhine-Westphalia.

ANNEX B. 3C-VACS MODELLING TOOLS

Brief Summary AIDRES study

The AIDRES project (Advancing industrial decarbonisation by assessing the future use of renewable energies in industrial processes), builds a spatially explicit database covering future demands for renewable energy carriers (electricity, gases, liquid fuels and heat) representing future pathways for 6 energy intensive energy industrial sectors (steel, chemical, cement, glass, fertilisers and refineries) in the European Union. More specifically the AIDRES project aims to:

Identify the magnitude of renewable energy demand for potential technological innovation paths of energy intensive industries towards carbon neutrality and more circularity, at medium (2030) and long term (2050). Compare effectiveness, efficiency and investment needs of technological innovation path options. Identify potential symbiosis with other sectors. Determine where resulting renewable energy demands will be located within the EU. Full report available at the website of the European Commission, DG Energy [102].

3C-VaCS Olefins production routes and assumptions

Table 9. Overview of olefins production routes per 3C-VaCS scenario.

ROUTE	SCENARIO
((COEL)MeOH)O	Global effort
((COEL)MeOH)O-MEA	Global effort
(0LN+15BN-Local+85BN-Import)O	Global effort
(0LN+15BN-Local+85BN-Import)O-MEA	Global effort
(0LN+15BN-Local+85BN-Import+EL)O	Global effort
(0MeOH+19BMeOH-Local+81BMeOH-Import)O	Global effort
(0MeOH+19BMeOH-Local+81BMeOH-Import)O-MEA	Global effort
((BM)MeOH)O-MEA	Global effort
(LN+EL)O	Global effort
(MeOH)O	Global effort
(MeOH)O-MEA	Global effort
ethane cracker H ₂ +CH ₄ with CCS	Global effort
((COEL)MeOH)O	Global effort - no CDR
((COEL)MeOH)O-MEA	Global effort - no CDR
(0LN+15BN-Local+85BN-Import)O	Global effort - no CDR
(0LN+15BN-Local+85BN-Import)O-MEA	Global effort - no CDR
(0LN+15BN-Local+85BN-Import+EL)O	Global effort - no CDR
(0MeOH+19BMeOH-Local+81BMeOH-Import)O	Global effort - no CDR
(0MeOH+19BMeOH-Local+81BMeOH-Import)O-MEA	Global effort - no CDR
(LN+EL)O	Global effort - no CDR
(MeOH)O	Global effort - no CDR
(MeOH)O-MEA	Global effort - no CDR
ethane cracker H ₂ +CH ₄ with CCS	Global effort - no CDR

((COEL)MeOH)O	limited biomass
((COEL)MeOH)O-MEA	limited biomass
(75LN+15BN-Local+10PN)O	limited biomass
(75LN+15BN-Local+10PN)O-MEA	limited biomass
(75LN+15BN-Local+10PN+EL)O	limited biomass
(81 e-MeOH-Import+19BMeOH-Local)O	limited biomass
(81 e-MeOH-Import+19BMeOH-Local)O-MEA	limited biomass
(LN)O	limited biomass
(LN)O-MEA	limited biomass
(LN+EL)O	limited biomass
ethane cracker H2+CH4 with CCS	limited biomass
((COEL)MeOH)O	limited biomass - no CDR
((COEL)MeOH)O-MEA	limited biomass - no CDR
(75LN+15BN-Local+10PN)O	limited biomass - no CDR
(75LN+15BN-Local+10PN)O-MEA	limited biomass - no CDR
(75LN+15BN-Local+10PN+EL)O	limited biomass - no CDR
(81 e-MeOH-Import+19BMeOH-Local)O	limited biomass - no CDR
(81 e-MeOH-Import+19BMeOH-Local)O-MEA	limited biomass - no CDR
(LN)O	limited biomass - no CDR
(LN)O-MEA	limited biomass - no CDR
(LN+EL)O	limited biomass - no CDR
ethane cracker H2+CH4 with CCS	limited biomass - no CDR
((COEL)MeOH)O	Maximum Biomass
((COEL)MeOH)O-MEA	Maximum Biomass
(0LN+15BN-Local+85BN-Import)O	Maximum Biomass
(0LN+15BN-Local+85BN-Import)O-MEA	Maximum Biomass
(0LN+15BN-Local+85BN-Import+EL)O	Maximum Biomass
(0MeOH+19BMeOH-Local+81BMeOH-Import)O	Maximum Biomass
(0MeOH+19BMeOH-Local+81BMeOH-Import)O-MEA	Maximum Biomass
((BM)MeOH)O-MEA	Maximum Biomass
(LN)O	Maximum Biomass
(LN)O-MEA	Maximum Biomass
(LN+EL)O	Maximum Biomass
ethane cracker H2+CH4 with CCS	Maximum Biomass
((COEL)MeOH)O	Maximum Biomass - no CDR
((COEL)MeOH)O-MEA	Maximum Biomass - no CDR
(0LN+15BN-Local+85BN-Import)O	Maximum Biomass - no CDR
(0LN+15BN-Local+85BN-Import)O-MEA	Maximum Biomass - no CDR
(0LN+15BN-Local+85BN-Import+EL)O	Maximum Biomass - no CDR
(0MeOH+19BMeOH-Local+81BMeOH-Import)O	Maximum Biomass - no CDR
(0MeOH+19BMeOH-Local+81BMeOH-Import)O-MEA	Maximum Biomass - no CDR

((BM)MeOH)O-MEA	Maximum Biomass - no CDR
(LN)O	Maximum Biomass - no CDR
(LN)O-MEA	Maximum Biomass - no CDR
(LN+EL)O	Maximum Biomass - no CDR
ethane cracker H ₂ +CH ₄ with CCS	Maximum Biomass - no CDR
(75LN+15BN-Local+10PN)O-MEA	Net-zero (100 % decarbonised industry)
(75LN+15BN-Local+10PN+EL)O	Net-zero (100 % decarbonised industry)
(81 e-MeOH-Import+19BMeOH-Local)O-MEA	Net-zero (100 % decarbonised industry)
ethane cracker H ₂ +CH ₄ with CCS	Net-zero (100 % decarbonised industry)
(75LN+15BN-Local+10PN)O-MEA	Net-zero (100 % decarbonised industry) - no CDR
(75LN+15BN-Local+10PN+EL)O	Net-zero (100 % decarbonised industry) - no CDR
(81 e-MeOH-Import+19BMeOH-Local)O-MEA	Net-zero (100 % decarbonised industry) - no CDR
ethane cracker H ₂ +CH ₄ with CCS	Net-zero (100 % decarbonised industry) - no CDR
((COEL)MeOH)O	RED III
((COEL)MeOH)O-MEA	RED III
(75LN+15BN-Local+10PN)O	RED III
(75LN+15BN-Local+10PN)O-MEA	RED III
(75LN+15BN-Local+10PN+EL)O	RED III
(81 e-MeOH-Import+19BMeOH-Local)O	RED III
(81 e-MeOH-Import+19BMeOH-Local)O-MEA	RED III
(LN)O	RED III
(LN)O-MEA	RED III
(LN+EL)O	RED III
ethane cracker H ₂ +CH ₄ with CCS	RED III
((COEL)MeOH)O	RED III - no CDR
((COEL)MeOH)O-MEA	RED III - no CDR
(75LN+15BN-Local+10PN)O	RED III - no CDR
(75LN+15BN-Local+10PN)O-MEA	RED III - no CDR
(75LN+15BN-Local+10PN+EL)O	RED III - no CDR
(81 e-MeOH-Import +19BMeOH-Local)O	RED III - no CDR
(81 e-MeOH-Import +19BMeOH-Local)O-MEA	RED III - no CDR
(LN)O	RED III - no CDR
(LN)O-MEA	RED III - no CDR
(LN+EL)O	RED III - no CDR
ethane cracker H ₂ +CH ₄ with CCS	RED III - no CDR

Table 10. Description of olefin production routes used in the 3C-VaCS scenarios.

#	ROUTE	DESCRIPTION
1	((BM)MeOH)O-MEA	Methanol to olefines using 100 % EU imported bio-methanol + carbon capture
2	((COEL)MeOH)O	Methanol (based on co-electrolysis) to olefins
3	((COEL)MeOH)O-MEA	Methanol (based on co-electrolysis) to olefins + carbon capture
4	(0LN+15BN-Local+85BN-Import)O	Naphtha cracker using 15 % local bio-naphtha and 85 % EU imported bio-naphtha
5	(0LN+15BN-Local+85BN-Import)O-MEA	Naphtha cracker using 15 % local bio-naphtha and 85 % EU imported bio-naphtha + carbon capture + carbon capture
6	(0LN+15BN-Local+85BN-Import+EL)O	Naphtha cracker using 15 % local bio-naphtha and 85 % EU imported bio-naphtha + electrification of heat
7	(0MeOH+19BMeOH-Local+81BMeOH-Import)O	Methanol to olefines using 19 % local bio-methanol and 81 % EU imported bio-methanol
8	(0MeOH+19BMeOH-Local+81BMeOH-Import)O-MEA	Methanol to olefines using 19 % local bio-methanol and 81 % EU imported bio-methanol + carbon capture
9	(75LN+15BN-Local+10PN)O	Naphtha cracker using 75 % oil based naphtha, 15 % local bio-naphtha and 10% py-oil
10	(75LN+15BN-Local+10PN)O-MEA	Naphtha cracker using 75 % oil based naphtha, 15 % local bio-naphtha and 10% py-oil + carbon capture
11	(75LN+15BN-Local+10PN+EL)O	Naphtha cracker using 75 % oil based naphtha, 15 % local bio-naphtha and 10% py-oil + electrification of heat
12	(81MeOH-Import+19BMeOH-Local)O	81% Imported e-methanol to olefins with 19 % local bio-methanol
13	(81MeOH-Import+19BMeOH-Local)O-MEA	81% Imported e-methanol to olefins with 19 % local bio-methanol + carbon capture
14	(LN)O	Naphtha cracker using 100 % oil based naphtha
15	(LN)O-MEA	Naphtha cracker using 100 % oil based naphtha + carbon capture
16	(LN+EL)O	Naphtha cracker using 100 % fossil based naphtha + electrification of heat
17	(MeOH)O	Methanol to olefins
18	(MeOH)O-MEA	Methanol to olefins + carbon capture
19	ethane cracker CH ₄ with CCS	Ethane cracker with CH ₄ used for heat + carbon capture
20	ethane cracker H ₂ +CH ₄ with CCS	Ethane cracker with H ₂ and CH ₄ used for heat + carbon capture

Table 11. Cost and CO₂ related parameters for olefin production routes used in the 3C-VaCS scenarios in 2050.

SCENARIO	CONFIGURATION	CAPEX (eur/t)	OPEX (eur/t)	CO ₂ ALLOWANCE (eur/t)	TOTEX (eur/t)	DIRECT EMISSIONS (t CO ₂ /t)	CAPTURED CO ₂ (t CO ₂ /t)
All	ethane cracker H ₂ +CH ₄ with CCS	103	814	45	962	0.094	0.850
All	(MeOH)O-MEA	24	3,196	7	3,227	0.015	0.132
All	(MeOH)O	21	3,194	71	3,286	0.147	0.000
All	(LN+EL)O	68	1,970	0	2,038	0.097	0.000
All	(LN)O-MEA	109	868	53	1,030	0.111	1.002
All	(LN)O	68	786	464	1,318	0.967	0.000
All	((COEL)MeOH)O-MEA	1,100	2,387	28	3,515	0.059	0.528
All	((COEL)MeOH)O	1,090	2,377	281	3,748	0.586	0.000

Global effort	(0MeOH+19BMeOH-Local+81BMeOH-Import)O-MEA	24	1,144	-63	1,105	-0.132	0.132
Global effort	(0MeOH+19BMeOH-Local+81BMeOH-Import)O	21	1,141	0	1,162	0.000	0.000
Global effort	(0LN+15BN-Local+85BN-Import+EL)O	68	3,374	0	3,442	0.000	0.000
Global effort	(0LN+15BN-Local+85BN-Import)O-MEA	109	2,271	-411	1,969	-0.856	1.002
Global effort	(0LN+15BN-Local+85BN-Import)O	68	2,190	0	2,258	0.000	0.000
Global effort	((BM)MeOH)O-MEA	333	1,583	-708	1,208	-1.476	1.476
Global effort - no CDR	(0MeOH+19BMeOH-Local+81BMeOH-Import)O-MEA	24	1,144	0	1,168	-0.132	0.132
Global effort - no CDR	(0MeOH+19BMeOH-Local+81BMeOH-Import)O	21	1,141	0	1,162	0.000	0.000
Global effort - no CDR	(0LN+15BN-Local+85BN-Import+EL)O	68	3,374	0	3,442	0.000	0.000
Global effort - no CDR	(0LN+15BN-Local+85BN-Import)O-MEA	109	2,271	0	2,380	-0.856	1.002
Global effort - no CDR	(0LN+15BN-Local+85BN-Import)O	68	2,190	0	2,258	0.000	0.000
Global effort - no CDR	((BM)MeOH)O-MEA	333	1,583	0	1,916	-1.476	1.476
limited biomass	(81MeOH+19BMeOH-Local)O-MEA	24	2,677	-6	2,695	-0.013	0.132
limited biomass	(81MeOH+19BMeOH-Local)O	21	2,675	57	2,753	0.119	0.000
limited biomass	(75LN+15BN-Local+10PN+EL)O	68	2,035	0	2,103	0.083	0.000
limited biomass	(75LN+15BN-Local+10PN)O-MEA	109	933	-63	979	-0.131	1.002
limited biomass	(75LN+15BN-Local+10PN)O	68	851	348	1,267	0.725	0.000
limited biomass - no CDR	(81MeOH+19BMeOH-Local)O-MEA	24	2,790	0	2,814	-0.013	0.132
limited biomass - no CDR	(81MeOH+19BMeOH-Local)O	21	2,787	57	2,865	0.119	0.000
limited biomass - no CDR	(75LN+15BN-Local+10PN+EL)O	68	2,188	0	2,256	0.083	0.000
limited biomass - no CDR	(75LN+15BN-Local+10PN)O-MEA	109	1,086	0	1,195	-0.131	1.002
limited biomass - no CDR	(75LN+15BN-Local+10PN)O	68	1,004	348	1,420	0.725	0.000
Maximum Biomass	(0MeOH+19BMeOH-Local+81BMeOH-Import)O-MEA	24	1,022	-63	983	-0.132	0.132
Maximum Biomass	(0MeOH+19BMeOH-Local+81BMeOH-Import)O	21	1,019	0	1,040	0.000	0.000
Maximum Biomass	(0LN+15BN-Local+85BN-Import+EL)O	68	3,007	0	3,075	0.000	0.000
Maximum Biomass	(0LN+15BN-Local+85BN-Import)O-MEA	109	1,905	-411	1,603	-0.856	1.002

Maximum Biomass	(0LN+15BN-Local+85BN-Import)O	68	1,823	0	1,891	0.000	0.000
Maximum Biomass - no CDR	(0MeOH+19BMeOH-Local+81BMeOH-Import)O-MEA	24	1,610	0	1,634	-0.132	0.132
Maximum Biomass - no CDR	(0MeOH+19BMeOH-Local+81BMeOH-Import)O	21	1,607	0	1,628	0.000	0.000
Maximum Biomass - no CDR	(0LN+15BN-Local+85BN-Import+EL)O	68	4,037	0	4,105	0.000	0.000
Maximum Biomass - no CDR	(0LN+15BN-Local+85BN-Import)O-MEA	109	2,935	0	3,044	-0.856	1.002
Maximum Biomass - no CDR	(0LN+15BN-Local+85BN-Import)O	68	2,853	0	2,921	0.000	0.000
Net-zero (100% decarbonised industry)	(81MeOH+19BMeOH-Local)O-MEA	24	2,677	-6	2,695	-0.013	0.132
Net-zero (100% decarbonised industry)	(75LN+15BN-Local+10PN+EL)O	68	2,035	0	2,103	0.000	0.000
Net-zero (100% decarbonised industry)	(75LN+15BN-Local+10PN)O-MEA	109	933	-63	979	-0.131	1.002
Net-zero (100% decarbonised industry) - no CDR	(81MeOH+19BMeOH-Local)O-MEA	24	2,790	0	2,814	-0.013	0.132
Net-zero (100% decarbonised industry) - no CDR	(75LN+15BN-Local+10PN+EL)O	68	2,188	0	2,256	0.000	0.000
Net-zero (100% decarbonised industry) - no CDR	(75LN+15BN-Local+10PN)O-MEA	109	1,086	0	1,195	-0.131	1.002
RED III	(81MeOH+19BMeOH-Local)O-MEA	24	2,677	-6	2,695	-0.013	0.132
RED III	(81MeOH+19BMeOH-Local)O	21	2,675	57	2,753	0.119	0.000
RED III	(75LN+15BN-Local+10PN+EL)O	68	2,035	0	2,103	0.083	0.000
RED III	(75LN+15BN-Local+10PN)O-MEA	109	933	-63	979	-0.131	1.002
RED III	(75LN+15BN-Local+10PN)O	68	851	348	1,267	0.725	0.000
RED III - no CDR	(81MeOH+19BMeOH-Local)O-MEA	24	2,790	0	2,814	-0.013	0.132
RED III - no CDR	(81MeOH+19BMeOH-Local)O	21	2,787	57	2,865	0.119	0.000
RED III - no CDR	(75LN+15BN-Local+10PN+EL)O	68	2,188	0	2,256	0.000	0.000
RED III - no CDR	(75LN+15BN-Local+10PN)O-MEA	109	1,086	0	1,195	-0.131	1.002
RED III - no CDR	(75LN+15BN-Local+10PN)O	68	1,004	348	1,420	0.725	0.000

Calculations of bio-naphtha and bio-methanol costs

Table 12. Overview of bio-naphtha production costs for 2030 and 2050.

	horizon	configuration	direct emissions (t CO ₂ /t)	captured CO ₂ (t CO ₂ /t)	opex (eur/t)	capex (eur/t)	CDR (eur/t)	totex (eur/t)	electricity (kWh/t)	biomass (t/t)	hydrogen (kg/t)
local biomass price	2030	(BM)FT	0	0	1,301	335	0	1,635	851	4.93	60
	2030	(BM)FT-MEA	-1.667	1.667	1,306	367	-308	1,364	946	4.93	60
+ realistic hydrogen price	2050	(BM)FT	0	0	1,030	335	0	1,365	851	4.93	60
	2050	(BM)FT-MEA	-1.667	1.667	1,035	367	-800	602	946	4.93	60
local biomass price	2030	(BM)FT	0	0	1,157	335	0	1,491	851	4.93	60
	2030	(BM)FT-MEA	-1.667	1.667	1,162	367	-308	1,220	946	4.93	60
+ optimistic hydrogen price	2050	(BM)FT	0	0	939	335	0	1,274	851	4.93	60
	2050	(BM)FT-MEA	-1.667	1.667	945	367	-800	511	946	4.93	60
local biomass price	2030	(BM)FT	0	0	1,447	335	0	1,781	851	4.93	60
	2030	(BM)FT-MEA	-1.667	1.667	1,452	367	-308	1,510	946	4.93	60
+ conservative hydrogen price	2050	(BM)FT	0	0	1,229	335	0	1,564	851	4.93	60
	2050	(BM)FT-MEA	-1.667	1.667	1,234	367	-800	801	946	4.93	60

Table 13. Overview of imported bio-naphtha production costs for 2030 and 2050.

	horizon	configuration	direct emissions (t CO ₂ /t)	captured CO ₂ (t CO ₂ /t)	opex (eur/t)	capex (eur/t)	CDR (eur/t)	totex (eur/t)	electricity (kWh/t)	biomass (t/t)	hydrogen (kg/t)
local biomass price	2030	(BM)FT	0	0	1,907	335	0	2,242	851	4.93	60
	2030	(BM)FT-MEA	-1.667	1.667	1,912	367	-308	1,971	946	4.93	60
+ realistic hydrogen price	2050	(BM)FT	0	0	1,636	335	0	1,971	851	4.93	60
	2050	(BM)FT-MEA	-1.667	1.667	1,642	367	-800	1,208	946	4.93	60
local biomass price	2030	(BM)FT	0	0	1,763	335	0	2,098	851	4.93	60
	2030	(BM)FT-MEA	-1.667	1.667	1,768	367	-308	1,827	946	4.93	60
+ optimistic hydrogen price	2050	(BM)FT	0	0	1,546	335	0	1,880	851	4.93	60
	2050	(BM)FT-MEA	-1.667	1.667	1,551	367	-800	1,117	946	4.93	60
local biomass price	2030	(BM)FT	0	0	2,053	335	0	2,388	851	4.93	60
	2030	(BM)FT-MEA	-1.667	1.667	2,058	367	-308	2,117	946	4.93	60
+ conservative hydrogen price	2050	(BM)FT	0	0	1,835	335	0	2,170	851	4.93	60
	2050	(BM)FT-MEA	-1.667	1.667	1,841	367	-800	1,407	946	4.93	60

Table 14. Overview of local bio-methanol production cost (EUR/t) for 2030 and 2050.

	horizon	configuration	direct emissions (t CO ₂ /t)	captured CO ₂ (t CO ₂ /t)	opex (eur/t)	capex (eur/t)	CDR (eur/t)	totex (eur/t)	electricity (kWh/t)	biomass (t/t)
local biomass price	2030	(BM)MeOH	0	0	319	110	0	429	535	2.15
	2030	(BM)MeOH-MEA	-0.521	0.521	321	120	-96	345	562	2.15
	2050	(BM)MeOH	0	0	318	110	0	429	535	2.15
	2050	(BM)MeOH-MEA	-0.521	0.521	320	120	-250	190	562	2.15

Table 15. Overview of imported bio-methanol production cost (EUR/t) for 2030 and 2050.

	horizon	configuration	direct emissions (t CO ₂ /t)	captured CO ₂ (t CO ₂ /t)	opex (eur/t)	capex (eur/t)	CDR (eur/t)	totex (eur/t)	electricity (kWh/t)	biomass (t/t)
imported biomass price	2030	(BM)MeOH	0	0	584	110	0	694	535	2.15
	2030	(BM)MeOH-MEA	-0.521	0.521	586	120	-96	610	562	2.15
	2050	(BM)MeOH	0	0	583	110	0	694	535	2.15
	2050	(BM)MeOH-MEA	-0.521	0.521	585	120	-250	455	562	2.15

Calculation of bio-naptha and bio-methanol potential

Table 16. Calculation of the local bio-naptha potential based on the biomass availability in Belgium, the Netherlands and Germany.

countries	naptha/biomass conversion efficiency (%)	available biomass utilization (%)	available lignocellulosic biomass (kt) *	bio-naptha potential (kt)	naptha need (kt) **	bio-naptha potential (%)
BE-NL-DE	0.2	30	81,663	4,969	33,084	15

* Estimated based on the average lignocellulosic biomass availability in 2030 and 2050 for scenario 1 and 3 (see Annex G)

** Estimated based on the naptha cracker route ((LN)O) of AIDRES

Table 17. Calculation of the local bio-methanol potential based on the biomass availability in Belgium, the Netherlands and Germany.

countries	methanol/biomass conversion efficiency (%)	available biomass utilization (%)	available lignocellulosic biomass (kt) *	bio-methanol potential (kt)	methanol need (kt) **	bio-methanol potential (%)
BE-NL-DE	0.46	30	81,663	11,371	60,435	19

* Estimated based on the average lignocellulosic biomass availability in 2030 and 2050 for scenario 1 and 3 (see Annex G)

** Estimated based on the methanol to olefins route ((MeOH)O) of AIDRES

Table 18. Main input assumptions, pathways to produce ethylene.

Ref	Commodity	2030	2050
[1]	Naphtha based ethylene in TCR/EU in 2025 = 850 EUR/t		
[2]	Domestic biomass from Belgium, Netherlands, Germany	107 EUR/t	107 EUR/t
[3]	EU imported biomass cost	230 EUR/t	230 EUR/t
[4]	EU Oil based naphtha cost	550 EUR/t	550 EUR/t
[5]	EU Plastic waste cost	400 EUR/t	400 EUR t
[6]	Plastic waste-based pyrolysis oil cost	700 EUR/t	700 EUR/t
[7]	Domestic bio naphtha cost	1,364 EUR/t	602 EUR/t
[8]	EU imported bio naphtha cost	1,971 EUR/t	1,208 EUR/t
[9]	International imported bio naphtha cost	1,660 EUR/t	1,390 EUR/t
[10]	Imported ethane from USA (shale gas) cost	300 EUR/t	300 EUR/t
[11]	H2 cost realistic (EUR kg/H ₂) Belgium (BE), Netherlands (NL), Germany (DE)	BE 10.4 NL 10.1 DE 9.2	BE 5.3 NL 5.5 DE 5.4
[12]	H2 cost optimistic (EUR kg/H ₂)	BE 7.8 NL 7.9 DE 6	BE 3.5 NL 4.6 DE 3
[13]	H2 cost conservative (EUR kg/H ₂)	BE 13.1 NL 12.3 DE 11.6	BE 8.9 NL 8.4 DE 8.8
[14]	International import e-methanol cost	1,670 EUR/t	1,280 EUR/t
[15]	Domestic bio methanol cost	345 EUR/t	190 EUR/t
[16]	EU import bio-based methanol cost	610 EUR/t	455 EUR/t
[17]	International import bio-methanol cost	454 EUR/t	454 EUR/t
[18]	International imported e-ammonia cost	1,155 EUR/t	728 EUR/t
[19]	ETS Price/CO ₂ shadow cost	185 EUR/tCO ₂	480 EUR/tCO ₂

- [1] EU produced ethylene at 885 USD/t in 2023 [50], USD to Euro (x 1.0824) in 2025 (x 1.04)
- [2] Based on wood chips 20 % dry, in EUR2025 [134]
- [3] Based on wood pellets 10 % dry, in EUR2025 [135], [136]
- [4] Average EU oil based naphtha price during 2024-2025 [137]
- [5] Average EU plastic waste price in 2022-2023 [138], used in availability analysis in ANNEX H
- [6] 700 EUR/t was chosen based on 787 USD/t in January 2024 in the Netherlands [139], 730 USD/t in May 2024 in the Netherlands [139], 676 USD/t in 2025 in Germany [140].
- [7] Based on CAPEX [102], BM-FT(MEA) 367 EUR/t in Euro2025 + Adjusted MEA CC cost [141] + OPEX 1,306 EUR/t at 230 EUR/t biomass - CDR 308 EUR/t, in line with [142]
- [8] Based on CAPEX [102], BM-FT(MEA) 367 EUR/t in Euro2025 + Adjusted MEA CC cost [141] + OPEX 1,912 EUR/t at 230 EUR/t biomass - CDR 308 EUR/t, in line with [142]
- [9] Based on CAPEX [102], BM-FT(MEA) 367 EUR/t in Euro2025 + Adjusted MEA CC cost [141] + OPEX 1,912 EUR/t at 107 EUR/t biomass and no CDR, in line with [142].
- [10] Based on USA produced ethane price of 200 EUR/t [143] + shipping cost (based on LNG) of 100 EUR/t [144].
- [11] **Realistic 2030**, H2 cost based on electricity/grid (>100 GWh <1,000 GWh)/taxes comparison study CREG, febeliec results [115] + CO2 emissions factor of the grid as in National Trend TYNDP scenario [143]. **Realistic 2050**, based on non-market coupled PPA, low-cost electricity hours + H2 flexible storage Tables Table 21 and Table 22.
- [12] **Optimistic 2030**, H2 cost based on electricity/grid (>1,000 GWh) /taxes comparison study CREG, febeliec results [115] + CO2 emissions factor of the grid as in National Trend TYNDP scenario [145]. **Optimistic 2050**, based on non-market coupled PPA, low-cost electricity hours + H2 flexible storage Tables Table 21 and Table 22.
- [13] **Conservative 2030**, ((2 x realistic 2030) – optimistic 2030)/2. **Conservative 2050**, H2 cost based on electricity/grid (>100 GWh <1,000 GWh)/taxes comparison study CREG, febeliec results [115] + where febeliec average grid cost over BE-NL-DE have been multiplied with consumption peak factor (between 2025 – 2050) from average of three main National Trend TYNDP scenario [145].
- [14] International transport of e-molecules, ETF- PROCURA Project, H2 import coalition [146].
- [15] See Table 14, including CDR at 185 EUR/tCO₂ in 2030 and 480 EUR/tCO₂ in 2050.
- [16] See Table 15
- [17] See Table 15 + long distance shipping cost (30-50 EUR/t methanol) [147].
- [18] International transport of e-molecules PROCRA Project/H2 import coalition [146].
- [19] Based on climate neutrality by 2050 modeling for different sectors of the EU Commission [101].

Table 19. Current and future electricity prices in the TCR.

Ref	Electricity (EUR/MWh)	2030 BE-NL-DE	2050 BE-NL-DE
[1]	Energy		
	Realistic	102 – 98 – 98	90 – 85 – 87
	Optimistic	79 – 68 – 66	32 – 40 – 39
	Conservative	102 – 98 – 98	90 – 85 – 87
[2]	Grid tariffs		
	Realistic	15 – 21 – 4	24 – 24 – 24
	Optimistic	6 – 20 – 2	6 – 20 – 2
	Conservative	21 – 25 – 4	39 – 39 – 39
[3]	Taxes EUR levies		
	Realistic	3 – 2 – 2	3 – 2 – 2
	Optimistic	2 – 1 – 1	2 – 2 – 1
	Conservative	12 – 6 – 12	12 – 6 – 12
	Total		
	Realistic	120 – 122 – 103	117 – 111 – 113
	Optimistic	87 – 89 – 69	40 – 62 – 42
	Conservative	135 – 129 – 114	142 – 130 – 139

[1] 2030 realistic and conservative, 2050 conservative calculations: based electricity price comparison study CREG [115], ETS correction based on TYNDP scenarios [145] + derived projected national grid mission factors [145]. 2030 optimistic and 2050 realistic, optimistic calculations PPA based (Table 21).

[2] Grid tariffs based electricity price comparison study CREG [115] + Peak power demand based on average TYNDP scenarios [145].

[3] Grid tariffs based electricity price comparison study CREG [115].

Scenario building tool

The concept of the tool is to select cost-effective pathways for climate neutral chemical sector, which is input to the infrastructure analysis.

The tool consists of four main components:

- User interface Excel file,
- AIDRES database⁹,
- Python script to select AIDRES production routes based on user scenarios,
- Tableau interface to visualise the output of the tool.

User interface:

A user interface in MS Excel gives users the opportunity to select commodity prices and set other user preferences to define a 'scenario'. At this moment, the following options are available:

- **'energy_commodity_prices' tab:** users can select prices for electricity, natural gas, hydrogen, ammonia, methanol and ethylene. Various price options are available, based on several studies or existing TIMES-BE¹⁰ scenarios.

⁹ The AIDRES database is publicly available at https://energy.ec.europa.eu/publications/database-advancing-industrial-decarbonisation-assessing-future-use-renewable-energies-industrial_en [104].

¹⁰ IEA ETSAP-TIMES modelling framework has been used to calculate cost optimal pathways towards (near) net zero in 2050 for Belgium [148]. IEA ETSAP-TIMES modelling framework has been used to calculate cost optimal pathways towards (near) net zero in 2050 for Belgium [148].



- **‘biomass_distribution’ tab:** users can limit biomass usage for every product, region and time horizon (2030, 2050 or combination).
- **‘other variables’ tab:** users can set a CO₂ allowance price and a climate target (minimum emission reduction) for every product and time horizon combination.
- **‘flags’ tab:** Users can apply constraints, such as excluding specific technology routes that use biomass or CCS. Additionally, they can select one of the following selection criteria to define the scenario goal: ‘minimise costs’, ‘maximise hydrogen usage’ or ‘maximise electricity usage.’
- **‘user_defined_configuration’ tab:** if no existing route is found that meets the user requirements for a specific product and horizon combination, users can manually set an AIDRES technology route.

Script development:

- Recalculate the ‘variable opex’ of AIDRES based on the selected commodity prices and CO₂ allowance price.
- Apply the biomass usage limitations, climate targets and constraints to select production routes that meet these criteria,
- Apply the selection criteria to either minimise costs, maximise hydrogen usage or maximise electricity usage,
- The output of the script contains an AIDRES-based production route for every production site, product and horizon combination with economical parameters and data on production volumes, commodity usage and CO₂ emissions.

Industrial clustering approach

To evaluate optimal hydrogen infrastructure configurations, key industrial demand hubs are first identified as spatially concentrated clusters serving as potential network connection points. Clustering industrial spatial data reduces computational complexity and data requirements, which would otherwise be prohibitive if all individual sites and gas network segments were included. Density-Based Spatial Clustering of Applications with Noise (DBSCAN) is selected for clustering due to its suitability for spatial data and its ability to handle noise. It groups points based on a minimum number of neighbors within a specified distance, while unqualified points are classified as noise. DBSCAN is applied separately to the Netherlands and NRW, testing multiple parameter combinations to balance coverage, cluster count, and noise. Results are visually assessed, and nearby noise points are incorporated where appropriate to ensure full representation of industrial demand. Clusters are then mapped onto a prospective hydrogen network, initially based on the SciGrid Gas dataset [149]. This is complemented with TSO plans from Gasunie [150] and FNB Gas [151] to reflect future hydrogen infrastructure. Where GIS data is unavailable, visual alignment is used. Demand nodes are assigned by linking each cluster centroid to its nearest network connection point. To simplify the model, only network segments relevant to connecting clusters, production, or storage sites are retained. For Belgium, clustering is not performed due to detailed available data. Instead, the network configuration follows Fluxys’ 2040 outlook [152], with six predefined industrial clusters based on coordinates from Namazifard et al. [153]. An overview of the GIS-based methodology is provided in Figure 51.

1) INDUSTRIAL SITES AND H₂ NETWORK CANDIDATES

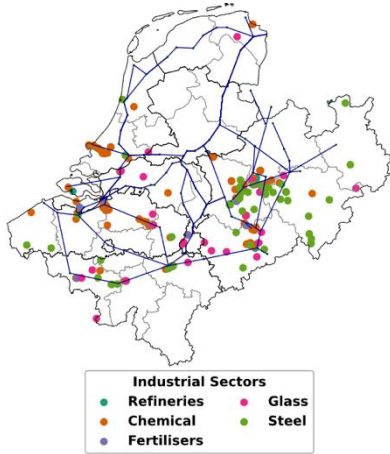

2) DBSCAN CLUSTERING ALGORITHM

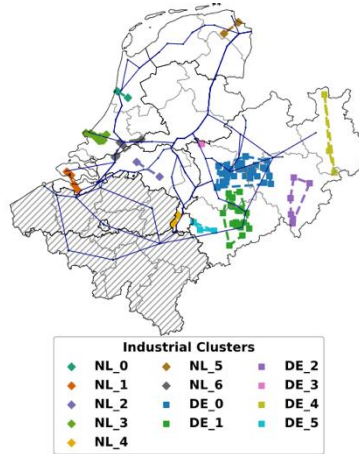

3) FINAL CANDIDATE NETWORK TOPOLOGY

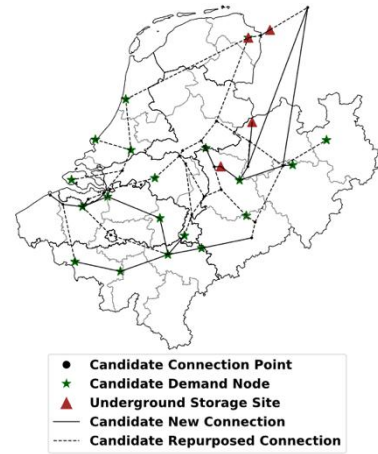

Figure 51. Overview of the main steps of the GIS analysis used to derive the simplified candidate hydrogen network topology in the Trilateral Industrial Region. The workflow includes the identification of candidate new and repurposed pipelines, industrial demand nodes and underground hydrogen storage sites.

ANNEX C. H₂ INFRASTRUCTURE MODEL

Table 20. Assumptions on the costs and performance parameters of renewable electricity generation and H₂ production technologies [145], [148], [154], [155], [156], [157], [158].

Technology	CAPEX (EUR2020/kW)		FOM (EUR2020/kW)		VOM (EUR2020/kWh)		Lifetime (years)		Efficiency	
	2030	2050	2030	2050	2030	2050	2030	2050	2030	2050
Solar PV ([1])	672	472	14.5	11.8	-	-	25	25	-	-
Onshore Wind	995	857	30.7	26.6	-	-	30	30	-	-
Offshore Wind	2,165	1,808	66.7	52.8	-	-	30	30	-	-
Onshore Electrolyser [2]	2,030	1,160	21	21	-	-	23	30	0.69	0.7
Offshore Electrolyser	5,086	2,101	78.6	78.3	0.003	0.003	20	20	0.68	0.74

[1] Commercial Solar PV.

[2] Medium-Scale Alkaline Electrolyser. The capital costs for electrolysis units are often underestimated in the literature. In this study, the 2020 capital cost of large-scale alkaline electrolysis was adopted from [159] and projected to 2030 and 2050 using a 10 % reduction learning curve. This cost was then adjusted for medium-scale electrolysers based on the scaling approach outlined in [160].

H₂ production costs

One essential metric for evaluating the cost of H₂ production is the levelised cost of hydrogen (LCOH). This metric integrates the annuity of capital expenditures (CAPEX) and operational expenditures (OPEX) of the production technology, alongside the levelised cost or price of the required input feedstock, such as natural gas for blue/grey hydrogen and electricity for green H₂ production.

Table 21. Levelised cost of H₂ for different configurations of electrolysis units placed in the energy system of TCR.

Technology	UNIT	2025	2030	2040	2050
GRID-CONNECTED ELECTROLYSER					
CAPACITY FACTOR	-	0.90	0.95	0.95	0.95
ELECTRICITY PRICE ¹¹	MEUR ₂₀₁₉ /GWh	0.079	0.098	0.129	-
LCOH	EUR ₂₀₁₉ /kg Lower Heating Value(LHV)	4.15	4.92	6.17	-
PPA-SOLAR ELECTROLYSER					
CAPACITY FACTOR	-	0.12	0.12	0.12	0.12
LCOE	MEUR ₂₀₁₉ /GWh	0.09	0.07	0.06	0.06

¹¹ Electricity price is taken from an in-house EU-level power system optimization model using the data from TYNDP2020 Distributed Energy scenario (an annual average across the TCR has been considered).

LCOH	MEUR ₂₀₁₉ /kg (LHV)	5.06	5.03	4.27	3.72
PPA-WIND ONSHORE ELECTROLYSER					
CAPACITY FACTOR		0.21	0.21	0.21	0.21
LCOE	MEUR ₂₀₁₉ /GWh	0.05	0.05	0.05	0.05
LCOH	MEUR ₂₀₁₉ /kg (LHV)	4.03	3.33	2.95	2.71
PPA-HYBRID ELECTROLYSER					
CAPACITY FACTOR	-				
LCOE	MEUR ₂₀₁₉ /GWh	To be calculated based on an optimisation model			
LCOH	MEUR ₂₀₁₉ /kg (LHV)				
PPA-WIND OFFSHORE ELECTROLYSER					
CAPACITY FACTOR	-	0.4	0.4	0.4	0.4
LCOE	MEUR ₂₀₁₉ /GWh	0.16	0.15	0.13	0.04
LCOH	MEUR ₂₀₁₉ /kg (LHV)	3.74	3.42	2.6	2.21
STEAM METHANE REFORMING WITH CC					
CAPACITY FACTOR	-	0.95	0.95	0.95	0.95
NATURAL GAS PRICE	MEUR ₂₀₁₉ /GWh	0.032	0.032	0.032	0.032
CO2 Price	MEUR ₂₀₁₉ /tCO2	80	185	250	480
LCOH	MEUR ₂₀₁₉ /kg (LHV)	1.01	1.50	1.80	2.11

Table 22. Assumptions on the costs and performance parameters of storage technologies in 2050 [161], [162].

Technology	CAPEX (EUR ₂₀₂₀ /kWh)	FOM (EUR ₂₀₂₀ /kW)	VOM (EUR ₂₀₂₀ /kWh)	Lifetime (years)	Charge efficiency	Discharge efficiency	Storage Loss	Charge/Discharge Time (hours)
Battery	200	0.6	0.0002	25	0.985	0.975	-	4
Underground H ₂ storage (Salt cavern)	1.34	-	-	100	0.99	1	- ¹	384
Liquified H ₂ tank ³	1.62	0.044	-	30	0.76	1	0.0013 ²	12

¹ No boil-off loss is assumed.

² Around 3 % boil-off loss per day.

³ Considering the liquefaction CAPEX, OPEX and losses.

Table 23. Costs of candidate pipes and compressors [163].

Candidate Pipe Sizes and Compressors	Type	CAPEX (MEUR/km) – (MEUR/MW _e ¹)	OPEX (% CAPEX)	Compression Capacity (MW _e /km)
Pipe DN900	New (4.7 GW)	3.2	0.9	-
	Repurposed (3.6 GW)	0.64	0.9	-
Compressor DN900	New	0.093 - 4	1.7	0.023
	Repurposed	0.04 - 4	1.7	0.01

¹ For compression stations.

Table 24. Values of LCOH from the stylized optimization model across different green H₂ production pathways [163].

Scenario	Optimistic (EUR/kg _{H2})	Realistic (EUR/kg _{H2})
Inland Green H ₂	3.2	5.4
Green H ₂ Import from South-EU	2.8	-
Offshore Green H ₂	4.4	-
Ammonia Import and Dehydrogenation	5.5	-

Due to the model's high spatial resolution, defined at the level of industrial clusters and the broad geographical scope of the TCR, the temporal resolution is down-sampled to a 3-hour time step using chronological clustering. This maintains a balance between computational tractability, adequate representation of short-term renewable variability, and the long-term arbitrage value of H₂ storage technologies (i. e., salt caverns and liquefied H₂ storage tanks).

Centralised storage in salt caverns offers high charge and discharge efficiency ($\eta_{c,st,y}$, $\eta_{d,st,y}$) and minimal self-discharge losses ($L_{boiloff}$) but is limited by slower responsiveness due to constrained



charge/discharge rates ($q_{c,st,t,y}$, $q_{d,st,t,y}$), governed by safe pressure gradients. In contrast, liquefied H₂ (LH₂) tanks provide faster response times but incur higher self-discharge losses (e. g., boil-off) and lower round-trip efficiency, resulting from the multiple energy-intensive phase transitions between gaseous and liquid H₂. Furthermore, LH₂ tanks, typically used for short-duration storage, exhibit lower capacity costs (EUR/MW) but higher energy costs (EUR/MWh), and require capital-intensive local liquefaction infrastructure, particularly for small-scale applications. By contrast, long-duration options such as salt caverns exhibit the opposite cost structure, with higher capacity costs (EUR/MW) but lower energy-specific costs (EUR/MWh). These techno-economic trade-offs are explicitly represented in both supply scenarios to determine the most cost-effective storage configuration under varying system flexibility needs. Equation 2 formalises this trade-off whereas $SOC_{st,t,y}$ denotes the state of charge of storage technology st in each model timestep t and investment period y , $cap_{st,y}^e$ defines the upper bound of SOC as the energy capacity of storage unit, and $T_{c,st}$ and $T_{d,st}$ captures the charge and discharge durations, representing the level of storage responsiveness subject to the technical constraints.

$$\begin{aligned}
 SOC_{st,t,y} &\leq cap_{st,y}^e \\
 SOC_{st,t,y} &= SOC_{st,t,y} \cdot (1 - L_{boiloff}) + q_{c,st,t,y} \cdot \eta_{c,st,y} - q_{d,st,t,y} / \eta_{d,st,y} \\
 q_{c,st,t,y} &\leq cap_{st,y}^e / T_{c,st} \\
 q_{d,st,t,y} &\leq cap_{st,y}^e / T_{d,st} \\
 \forall t \in T, \forall st \in ST, \forall y \in Y
 \end{aligned}$$

Equation 2. H₂ State of Charge optimisation.



ANNEX D. CO₂ INFRASTRUCTURE MODEL

This annex contains the full numerical results for the CO₂ infrastructure optimization. A first part contains the numeric results belonging to the base runs. A second part contains the cross-border sensitivity analysis on the CO₂ transport roll-out. The tables contain information on:

- The applied scenario: the base scenario name, the H₂ supply scenario name, the CDR credits scenario name.
- The amount of potential capture sites (modelling input) and optimised sites (modelling output). Some sites which are too far away for the network or too small industry clusters may disconnect from the network as calculated by the model.
- The potential capture volume and optimised volume (in MtCO₂ per year) split in fossil volume, biogenic volume and bionaphta or methanol captured volume. The latter relates to the captured emissions at the production of the bionaphta or methanol (within the BE-NL-NRW) used at another industrial site within the region.
- Biomass use in TWh per year.
- The average transport and storage costs in EUR per tCO₂ per year. Multiplying this number with the total optimised capture volume generates the total T&S costs in million euros per year.

In general, the results should be used in a comparative fashion, between scenarios. They can give somewhat an estimation on what a system-optimal configuration could look like, but most likely do not convey the true costs or volumes a company or T&S operator experiences in reality for several reasons (e. g. socio-economic, political or techno-economic reasons).

Base scenario results

Table 25 and Table 26 provide an overview of the scenario results. Only the scenarios with a realistic cost of hydrogen are considered, because the hydrogen cost had a very limited effect on the CO₂ infrastructure. The numeric results below describe the following information for the years 2030 and 2050 and the scenario assumptions in chapter 3.2.

- The pathways with CDR credits enabled typically improve the business case for CCS of biogenic CO₂.
- Total capture potential in Mt CO₂, ranging from 15 to 79 Mt CO₂, for the entire Belgium, Netherlands and North-Rhine Westphalia area, as calculated by the model.
- The optimised captured volumes, ranging from 14 Mt to 77 Mt CO₂ for the entire Belgium, Netherlands and North-Rhine Westphalia area, as calculated by the model.
- Biomass use ranges from almost zero to over 1,000 TWh/t CO₂. CDR credits typically increase the amount of used biomass as it allows to store negative emissions using bio-CCS technologies.
- Average T&S costs range from 26 to 77 EUR/t CO₂.

Base scenario	H2 supply	CDR credits	Max tot. capture sites	Optimised capture sites	Tot. capture potential (MtCO ₂ /a)	Optimised capture volume (MtCO ₂ /a)	Fossil capture volume (MtCO ₂ /a)	Bio capture volume (MtCO ₂ /a)	Bionaptha/MeOH capture volume (MtCO ₂ /a)	Biomass use (TWh/a)	Avg. T&S costs (EUR/tCO ₂)
low cost domestic biomass	Realistic	Yes	198	173	62	60	50	10	0	26	34
Maximum available biomass	Realistic	Yes	198	173	62	60	50	10	0	26	34
Net-zero	Realistic	Yes	77	72	50	49	30	13	6	115	40
RED III	Realistic	Yes	198	173	62	60	50	10	0	26	34
Global effort	Realistic	Yes	77	61	25	22	11	11	0	507	45
low cost domestic biomass	Realistic	No	198	173	59	57	57	0	0	0	35
Maximum available biomass	Realistic	No	198	173	59	57	57	0	0	0	35
Net-zero	Realistic	No	77	72	42	41	30	11	0	105	45
RED III	Realistic	No	198	173	59	57	57	0	0	0	35
Global effort	Realistic	No	46	32	19	17	11	6	0	499	49

Table 25. Main numeric CCTS optimisation results for the year 2030.

Base scenario	H2 supply	CDR credits	Max tot. capture sites	Optimised capture sites	Tot. capture potential (MtCO ₂ /a)	Optimised capture volume (MtCO ₂ /a)	Fossil capture volume (MtCO ₂ /a)	Bio capture volume (MtCO ₂ /a)	Bionaptha/MeOH capture volume (MtCO ₂ /a)	Biomass use (TWh/a)	Avg. T&S costs (EUR/tCO ₂)
low cost domestic biomass	Realistic	Yes	225	201	79	77	58	13	6	116	28
Maximum available biomass	Realistic	Yes	225	200	72	70	37	23	10	1042	26
Net-zero	Realistic	Yes	77	66	49	44	28	10	6	278	33
RED III	Realistic	Yes	225	201	79	77	58	13	6	116	28
Global effort	Realistic	Yes	77	69	18	17	4	13	0	508	67
low cost domestic biomass	Realistic	No	225	201	69	67	67	0	0	0	27
Maximum available biomass	Realistic	No	225	201	69	67	67	0	0	0	27
Net-zero	Realistic	No	77	73	40	39	28	11	0	277	40
RED III	Realistic	No	225	201	69	67	67	0	0	0	27
Global effort	Realistic	No	50	44	15	14	4	10	0	499	77

Table 26. Main numeric CCTS optimisation results for the year 2050.

Cross border/ Geographic sensitivities

The assessment examines some sensitivities in relation to allowed or enforced cross-border transport connections and storage options. These are:

- The UK storage possibility (in 2030)
- The NRW-NL vs. the NRW-BE CO₂ transport connection
- The importance of connections between BE-NL

Table 25 and Table 26 we use the global effort scenario as baseline for the second sensitivity (2030, realistic H₂ prices and with CDR credits). For the first and the third sensitivity runs the limited biomass scenario is used (2030, realistic H₂ prices and with CDR credits). Table 27 describes the outcomes by comparing them to the base scenario. A column with the average T&S costs increase or decrease is added as well as a column that expresses the total absolute system cost changes. The latter includes also the production costs (capex and opex) at the industry sites.

Base scenario		H2 supply	CDR credits	Max tot. capture	Optimise capture	Tot. potential capture (MtCO ₂ /a)	Optimise volume (MtCO ₂ /a)	Fossil volume (MtCO ₂ /a)	Bio volume (MtCO ₂ /a)	Bionaphth a/MeOH capture volume (MtCO ₂ /a)	Biomass use (TWh/a)	Avg. T&S costs (EUR/tCO ₂ e)	% T&S costs Increase/decrease from baseline	Tot system cost (MEUR)
low cost domestic biomass	Base	Realistic	Yes	198	173	62.21	60.08	50.24	9.84	0	25.60	34.27	0	0
low cost domestic biomass	UK storage 2030	Realistic	Yes	198	173	62.21	60.08	50.24	9.84	0	25.60	27.83	-18.792	-386.83
low cost domestic biomass	No AR	Realistic	Yes	198	173	62.21	60.08	50.24	9.84	0	25.60	34.74	1.371	28.24
low cost domestic biomass	No AR, KD	Realistic	Yes	198	176	62.21	59.97	50.12	9.84	0	25.60	34.24	-0.088	42.34
low cost domestic biomass	No AR, KD, DT	Realistic	Yes	198	175	62.21	59.94	50.1	9.84	0	25.60	34.43	0.467	64.30
low cost domestic biomass	No AR, KD, DT, BV	Realistic	Yes	198	175	62.21	59.95	50.1	9.84	0	25.60	34.92	1.897	93.25
Global efforts	Base	Realistic	Yes	77	61	25.16	22.22	11.18	11.04	0	507.17	44.91	0	0
Global efforts	Forced DRC	Realistic	Yes	77	60	25.16	21.68	11.17	10.51	0	506.57	44.69	-0.490	31.79

Legend:	AR	Antwerp-Rotterdam
	KD	Kruikebe-Dordrecht
	DT	Diest-Tilburg
	BV	Brugge-Vlissingen
	DRC	Delta-Rhine Corridor

Table 27. Collection of quantitative results of all sensitivity analyses. Differences in cost are calculated based on the infrastructure components only (using the relative cost difference) and not based on the total system costs incl. industry production costs (using the absolute cost difference compared to the base scenario).

UK storage possibility: With this sensitivity we relax the assumption that storage in UK is not possible in 2030 (Figure 52). This allows us to directly assess the value of nearby storage locations within the same scenario.

Result: Low cost domestic biomass (2030, CDR): The total transport and storage costs decrease by almost 19 % by allowing UK storage. The total absolute system costs decreases by almost 400 MEUR. This is entirely related to the infrastructure component as the participation and capture volumes do not increase but stay the same. This highlights the relative importance of nearby UK storage sites within the early development of the CO₂ value chain.

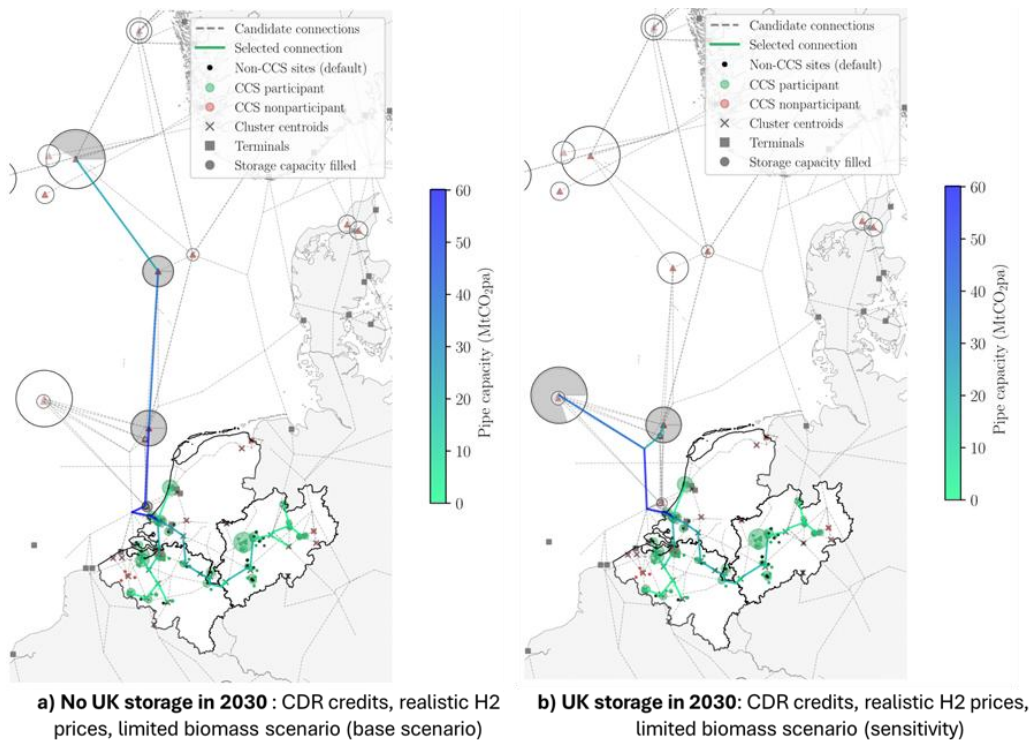

Figure 52. Sensitivity analysis on UK storage in 2030.

NRW – BE vs. NRW – NL: With this sensitivity we force our model to select the Delta Rhine Corridor (DRC) as an investment option. This allows us to assess the relative importance of the NRW-BE connection relative to the NRW-NL connection.

Results: Global efforts (2030, CDR): Quantitative results indicate a very small total infrastructure cost decrease of about 0.5 % compared to the cost optimal result (Figure 53, Figure 53a)). However, the total absolute total system cost increases to more than 30 MEUR. This can be explained by the significant changes in participating sites, shown by Figure 53b).

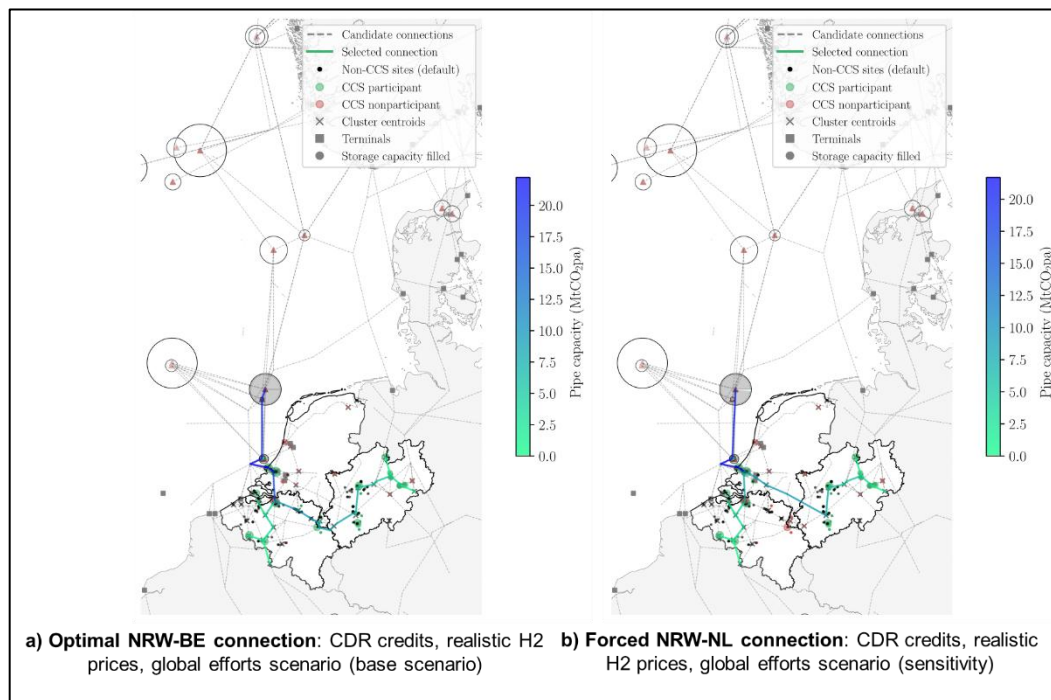

Figure 53. Sensitivity analysis on connections between NRW with either BE or NL.

BE – NL: With this sensitivity analysis we investigate the relative importance of the connections between the Antwerp region and the Netherlands. There are five important connections that we disable one-by-one:

- Connection Antwerp-Rotterdam (AR)
- Connection Kruikebeke-Dordrecht (KD)
- Connection Diest-Tilburg (DT)
- Connection Brugges-Vlissingen (BV)

Results: Low cost domestic biomass (2030, CDR): Table 27 and Figure 54 contain all quantitative results and pipeline visualisation results, respectively. The Zeebrugge connections which gets selected after disabling all other connections (1-4) turns out the most expensive, but still only slightly more costly than the other scenarios. Table reports a limited average T&S increase of 1.8 %. Total system costs (incl. the industry site costs) increase with almost 100 MEUR. Changed route configurations only have a negligible effect on CCS participants. In general, the results show the high importance of the Antwerp cluster connection towards the Netherlands.

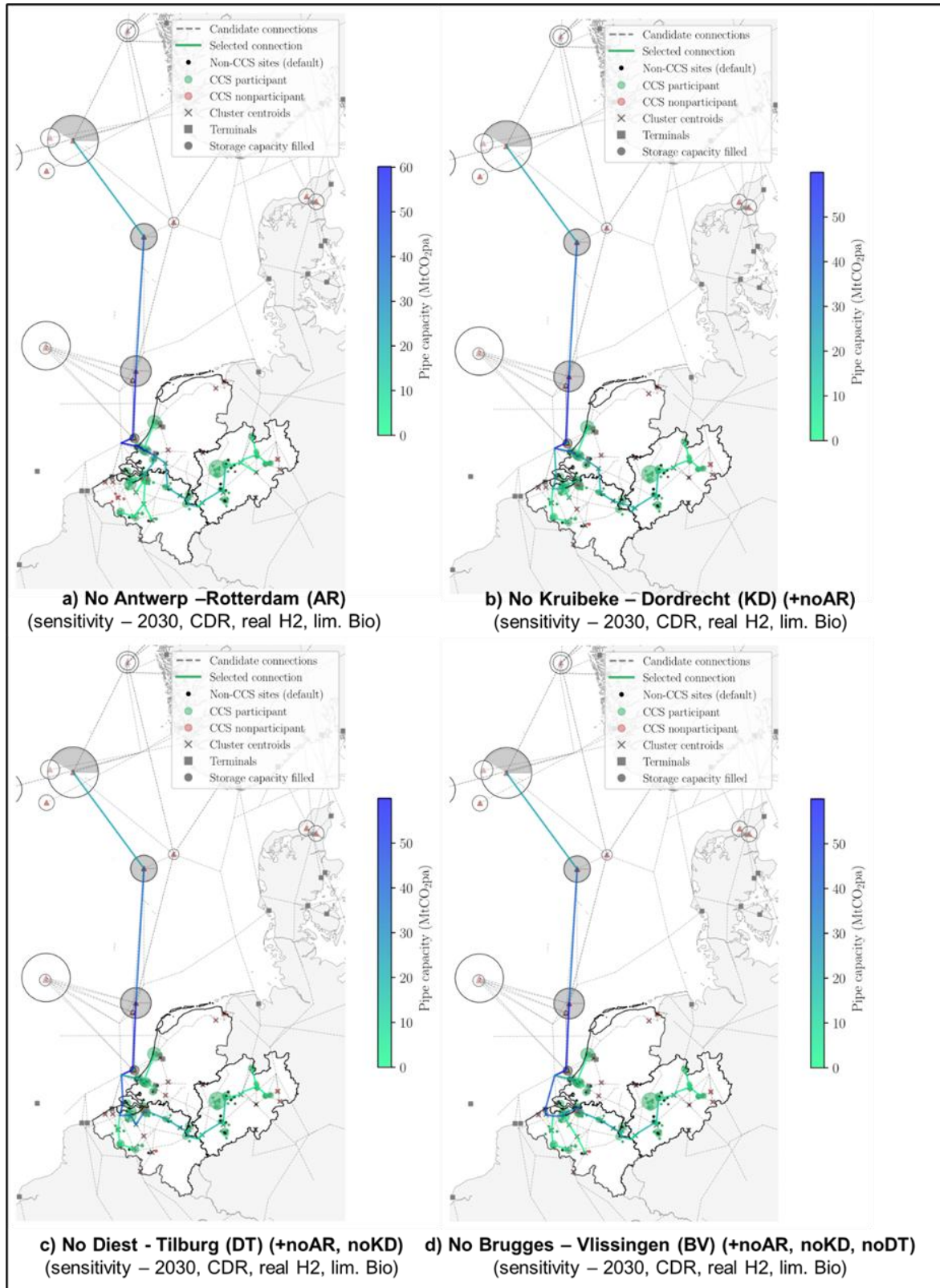

Figure 54. Sensitivity analysis on connections between BE and NL.

ANNEX E. BIOMASS BASED PATHWAYS FOR THE PRODUCTION OF OLEFINS & AROMATICS

Base chemicals such as olefins (ethylene, propylene, and butadiene), BTX (benzene, toluene, xylene, and other aromatics), and methanol are essential components of the chemical industry, playing a key role in the production of a wide range of materials and products. Olefins, particularly ethylene, propylene, and butadiene, are used in the production of plastics such as polyethylene and polypropylene, as well as synthetic rubbers, which are widely applied in packaging, construction, and consumer goods. Similarly, BTX compounds are important feedstocks for producing polymers like polyethylene terephthalate, synthetic fibres, resins, and coatings. Methanol is extensively used as a precursor for formaldehyde, acetic acid, and fuel additives such as Methyl Tertiary-Butyl Ether (MTBE). It is also attracting increasing interest as a maritime fuel. In addition, methanol serves as a key building block for producing base chemicals, including olefins and BTX, highlighting its importance in the chemical value chain.

The production of base chemicals such as olefins and aromatics predominantly depends on fossil feedstocks, resulting in significant CO₂ emissions due to the energy-intensive processes and scope-3 emissions involved. To address these environmental challenges, the chemical industry is exploring alternative pathways to produce these chemicals with a lower carbon footprint. This report examines three main groups of bio-based chemical production routes, i. e., via methanol, ethanol and naphtha (or liquid hydrocarbons); for olefins and BTX production (see Table 28). Only TRL > 5 technologies were selected for the assessment and technologies like hydrothermal liquefaction (HTL) are not considered as the oil from HTL requires further hydrotreatment and the whole system together is at low TRL. Also, decentralised bio-synthetic natural gas (SNG) production was not considered because the focus was on centralised systems as seen in the case of biogas. SNG is an interesting intermediate which can easily be plug-in with existing methanol units; however, this is not considered in this report.

Table 28. Pathways to produce base chemicals included in this study.

	Technology	Feedstock	Product
Methanol pathways	Methanol production via gasification of biomass	Lignocellulosic biomass	Methanol
	Methanol production via biogas	Other organic wastes & residues	Methanol
	Methanol-to-Olefins	Methanol	Olefins (ethylene, propylene)
	Methanol-to-Aromatics	Methanol	BTX
Ethanol pathways	Lignocellulosic biomass to ethanol	Lignocellulosic biomass	Ethanol
	Ethanol-to-Ethylene	Ethanol	Ethylene
Alternative cracker feed pathways	Biomass pyrolysis and upgrading		Bio-oil (Bio-naphtha and heavier fractions)
	Biomass gasification and syngas conversion (Fischer Tropsch)	Lignocellulosic biomass	Bio-oil (Bio-naphtha and heavier fractions)

The objective of this report is to provide an overview of these alternative pathways by outlining their process descriptions and performance metrics, including key inputs, outputs, and capital expenditures. The structured evaluation aims to support the transition towards a more sustainable and circular chemical industry.

Methanol pathways

- **Methanol production via gasification of biomass**

Methanol production through gasification of lignocellulosic biomass consists of several steps. The process begins with biomass pretreatment, which typically includes drying and particle size reduction. This is followed by biomass gasification, where the biomass is converted into syngas, a mixture of carbon monoxide and H₂. The gasification process uses oxygen as gasifying agent; thus, this step also includes an air separation unit to provide the system with the required oxygen flow. In the final step, syngas is catalytically converted into methanol under high pressure and moderate temperature. Biomass gasification is carried out at 850 °C [164], while methanol synthesis occurs at 300 °C and 80 bar [164].

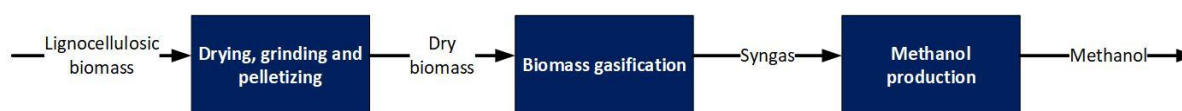

Figure 55. Simplified block flow diagram of biomass to methanol process [82].

Table 29 presents the mass and energy balances for methanol production from biomass. The flows indicate a substantial demand for cooling utilities and electricity, primarily due to the air separation unit and the compressors used in the methanol synthesis step. Approx. 50 % of the initial biomass mass (in dry basis) is converted into methanol, while the remaining carbon is released as biogenic CO₂ in the flue gas stream. The release of CO₂ is inherent to the gasification process, as the H₂-to-CO ratio in the biomass must be adjusted to meet the requirements for methanol synthesis. As a result, a portion of the carbon leaves the system as CO₂.

The methanol yield from biomass is consistent with values reported in the literature [82]. The waste streams contain a considerable fraction of nitrogen, originating from the air separation unit. Air separation is required to provide oxygen for the gasification step, which produces syngas from biomass to be used as feedstock for methanol synthesis.

Table 29. Mass and energy flows of methanol production via biomass gasification [82].

IMass	Mass in (kt)		Mass out (kt)	
	Biomass char (moisture content of 30 wt%)	1,429	Methanol	504
	Water	88	Flue gas (94 wt% CO ₂)	932
	Air	1,800	Waste water	442
			Nitrogen	1,381
		Ash	58	
Energy	Energy in (TJ/a)		Energy out (TJ/a)	
	Electricity	851		
	Heating	1,298		
	Cooling	12,603		
Economic	CAPEX including product purification section (Million EUR)		Basis year	
	710		Corrected to 2023 using CEPCI index	

The capital expenditure (CAPEX) for this process is based on the year 2023. The gasification reactor is a major cost component, which aligns with literature findings indicating the high cost of gasification technologies. Further advancements are necessary to achieve cost reductions in the future. Compressors also represent a significant share of CAPEX, mainly due to the high pressures required in the methanol synthesis step. Separation columns further contribute to overall costs; particularly cryogenic columns used in the air separation unit and those required for methanol separation.

- **Methanol production via biogas**

Methanol production from biogas involves several stages. The process starts with the production of biogas from biomass through anaerobic digestion. The resulting biogas, primarily consisting of CH₄ and CO₂) is then upgraded and reformed to produce syngas, a mixture of H₂ and CO. This syngas is subsequently converted into methanol through catalytic synthesis under moderate temperature and high pressure as discussed above.

The biogas unit operates at 40 °C and 1 bar, with a biogas yield of 98 Nm³ per tonne of organic matter in the substrate, which is typical for manure-based digestion. The biogas composition is 64 vol% CH₄ and 36 vol% CO₂, representing a typical biogas composition. The conversion of organic matter in the digester follows these yields: 0.91 kg of digestate per kg of organic matter, and 0.08 kg of biogas per kg of organic matter. The product from the digester is separated into a crude gas stream and a wet stream containing the digestate.

Methanol production from biogas involves several key stages, starting with the upgrading of raw biogas, which consists mainly of CH₄ and CO₂, through a separation process to remove CO₂ and produce biomethane. This upgraded biomethane is then subjected to SMR, which converts methane into a syngas mixture primarily containing H₂ and CO. The separated CO₂ is not wasted, instead, it is mixed back with the syngas and fed into the methanol synthesis reactor. Methanol production can follow different process schemes, including direct CO₂ hydrogenation, where CO₂ is hydrogenated to methanol in a single reactor, or a reverse water gas shift reaction (r-WGS) step that first converts CO₂

into CO, which is then synthesised into methanol. Table 30 presents the mass and energy flows of the process of biomass to methanol via biogas via direct synthesis.

Methanol production via biogas requires significant inputs, including 62,331 kt per year of manure with 90 % moisture content and 15,625 kt per year of water, which is used exclusively for anaerobic digestion to maintain the required wet conditions. The process demands for heating and cooling are primarily for steam methane reforming and methanol synthesis.

Table 30. Mass and energy flows of methanol production via biogas [165].

	Mass in (kt)		Mass out (kt)	
Mass	Biomass (Manure at 90 wt% moisture)	62,331	Methanol	504
	Water	15,625	Flue gas (Mainly CO ₂)	64
			Waste water	70,229
			Digestate	7,159
	Energy in (TJ/a)		Energy out (TJ/a)	
Energy	Heating	1,128	Electricity	-879
	Cooling	739		
Economic	CAPEX including product purification section (Million EUR)		Basis year	
	447		Corrected to 2023 using CEPCI index	

As shown in Table 30, the total CAPEX for methanol production via biogas amounts to 447 Mio. EUR, with biogas production representing the 43 % share and reforming with methanol accounting for 57 % of the investment. This reflects the complexity and infrastructure requirements of anaerobic digestion and biogas upgrading. Steam methane reforming, although a crucial step in syngas production, requires a relatively lower investment, while methanol synthesis contributes significantly to the total cost due to the need for specialised reactors and separation systems.

- **Methanol-to-Olefins**

Methanol is fed to the MTO fluidised bed reactor operating at 30 bar and 450 °C. The MTO process produces ethylene and propylene along with other by-products (like methane, ethane, propane, C4's, benzene). The product mixture is separated into high purity products using a series of separation processes (like dehydration, cryogenic distillation, extractive distillation).

Table 31. Mass, energy and economic characteristics of methanol to olefin process [166].

Note: For energy positive sign means energy need and negative sign means energy production, catalyst is SAPO-34. The capacity of 2,300 kt/a methanol is used such as to produce about 300 kt/a ethylene, which is equivalent to the 1/3rd ethylene production in the Port of Rotterdam. Such an industrial scale methanol to olefin plant does not exist.

	Mass in (kt)		Mass out (kt)	
	Mass	Methanol	2,300	Methane
Combustion air		360	Ethylene	314
Catalyst		1	Ethane	9
			Propylene	398
			Propane	74
			C4 (assumed to butene)	106
			C5+ (assumed to be benzene)	80
			Flue gas	386
		Waste water	1,284	
	Energy in (TJ/a)		Energy out (TJ/a)	
	Energy	Low pressure steam	6,500	Medium pressure steam
Cooling water		9,743	High pressure steam	-68
Electricity		1,892		
Economic	CAPEX including product purification section (Million EUR)		Basis year	
	423		Corrected to 2023 using CEPCI index	

- **Methanol-to-Aromatics**

Methanol is fed into a fluidised bed MTA reactor (60 bar, 450 °C), producing benzene along with by-products like methane, ethane, propylene, propane, C4's, toluene, xylene. To increase the benzene yield, toluene and m-xylene, were further processed using a toluene disproportionation to benzene reactor and a m-xylene isomerisation unit. The final product mixture was separated into high-purity products using a series of advanced separation steps (dehydration, cryogenic distillation, extractive distillation).

Table 32. Mass, energy and economic characteristics of methanol to aromatics process [160].

Note: For energy positive sign means energy need and negative sign means energy production, catalyst is HZM-5. The capacity of 8,800 kt/a methanol is used such as to produce about 500 kt/a benzene, which is equivalent to the benzene production in the Port of Rotterdam. Such an industrial scale methanol to aromatics plant does not yet exist.

	Mass in (kt)		Mass out (kt)	
	Mass	Methanol	8,800	Ethylene
Combustion air		8,733	Ethane	195
Catalyst		4	Propylene	68
H ₂		17	Propane	641
			C4 (assumed to butene)	921
			Cumene	240
			Naphthalene	32
			O-xylene	5
			P-xylene	972
			Benzene	535
			Flue gas	9,012
		Waste water	4,914	
	Energy in (TJ/a)		Energy out (TJ/a)	
	Energy	Medium pressure steam	4,493	Low pressure steam
Cooling water		21,065	High pressure steam	-15
Electricity		5,122		
Economic	CAPEX including product purification section (Million EUR)		Basis year	
	3,676		Corrected to 2023 using CEPCI index	

Ethanol pathways

- **Lignocellulosic ethanol-to-Ethylene**

Lignocellulosic ethanol is a biofuel produced by converting the cellulosic and hemicellulose part in plant cell walls (lignocellulosic biomass) into ethanol through fermentation. It is considered a promising alternative to traditional ethanol, which is often made from food crops like corn or sugarcane.

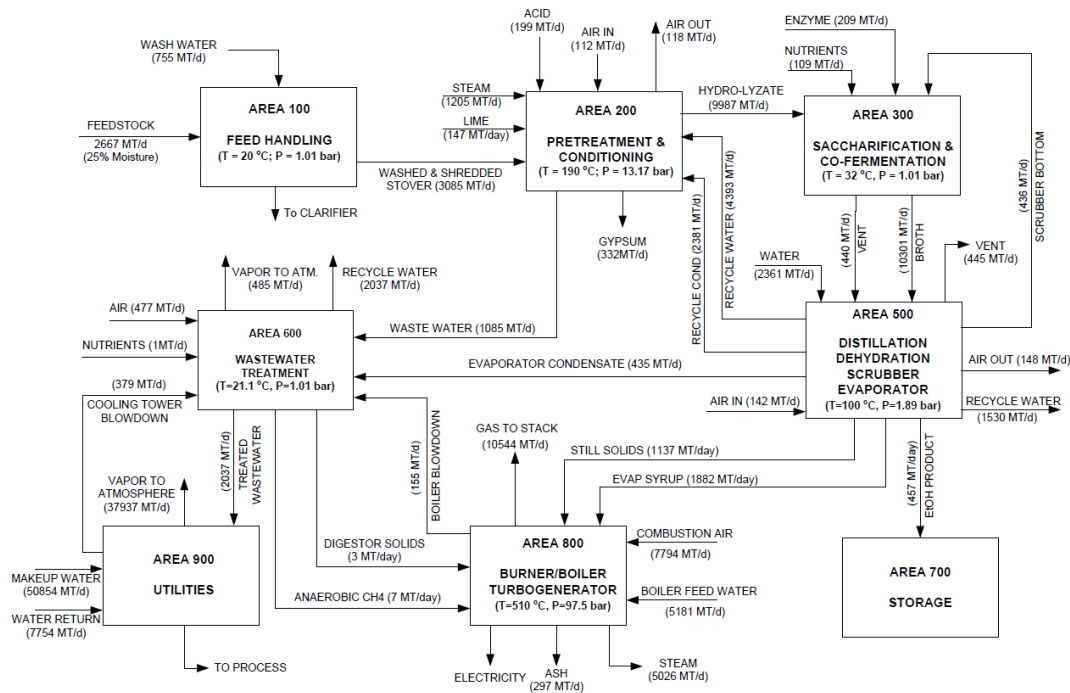

Figure 56. Block flow diagram of lignocellulosic ethanol process [167].

The process generally involves steps like, pretreatment (to expose the rigid structure of lignocellulosic biomass to make the cellulose and hemicellulose accessible for enzymatic hydrolysis), enzymatic hydrolysis (enzymes break down the cellulose and hemicellulose into fermentable sugars, primarily glucose and xylose), fermentation (microorganisms like yeast or bacteria ferment the sugars into ethanol) and product recovery (the ethanol is separated and purified).

Table 33. Mass flows and CAPEX for the production of lignocellulosic ethanol [167].

	Mass in (kt)		Mass out (kt)	
	Material	Value	Material	Value
Mass	Stover (with 25 % moisture content)	880	Ethanol	151
	Wash water	249	Waste water	358
	Steam	398	Gypsum	110
	Lime	49	Air (out)	88
	Acid	66	Vent (CO ₂)	147
	Air (in)	84	Recycle water	505
	Nutrients	36	Evaporator condensate	144
	Enzyme	69	Flue gas (combustion of still solids & evaporator syrup)	3,480
	Water	779	Ash	98
	Combustion air	2,572	To clarifier	101

Energy	Energy in (TJ/a)		Energy out (TJ/a)	
	Cooling water	472	Electricity	780
Economic	CAPEX including product purification section (Million EUR)		Basis year	
	529		Corrected to 2023 using CEPCI index	

Ethanol can be converted to ethylene through a dehydration reaction, which involves removing the water molecule. This process typically uses a catalyst, often an acidic material like alumina or a zeolite, and high temperatures. The reaction is endothermic, meaning it requires heat input, and is commonly performed in a fluidised bed reactor or other specialised reactors. The specific CAPEX from the reference for the ethanol dehydration process is around 0.08 EUR/kg ethylene.

Table 34. Mass flows and CAPEX for the ethanol to ethylene dehydration process [168].

Mass	Mass in (kt)		Mass out (kt)	
	Ethanol	271	Ethylene	164
		Waste water	107	
Energy	Energy in (TJ/a)		Energy out (TJ/a)	
	Electricity	230		
	Natural gas	432		
Economic	CAPEX including product purification section (Million EUR)		Basis year	
	14		Corrected to 2023 using CEPCI index	

Alternative cracker feed pathways

One option to defossilise the steam cracking sector is to replace naphtha with a renewable feedstock. Since the impact of co-processing bio-oils feedstocks is limited to few percentages due to formation of coke because of heavier fractions in bio-oil, the bio-oil is subject to hydrotreating and naphtha separation. It is assumed that this hydrotreated bio-naphtha is compatible with downstream processes such as cracking and separation would remain unchanged from current steam crackers. These downstream processes are not included in this analysis. The focus of this analysis is on various technologies for producing bio-naphtha.

- **Biomass Pyrolysis and upgrading**

The pyrolysis process converts biomass into bio-oil, syngas, and char by heating it to 400-600 ° C in the absence of oxygen. The process involves drying biomass to remove moisture, followed by thermal decomposition into the three fractions. The volatile vapours are cooled to condense bio-oil, while gases and char are separated. The bio-oil yield of the fast pyrolysis process is around 57 wt%. However, the bio-oil produced has a high oxygen content, making it unstable and unsuitable for direct use.

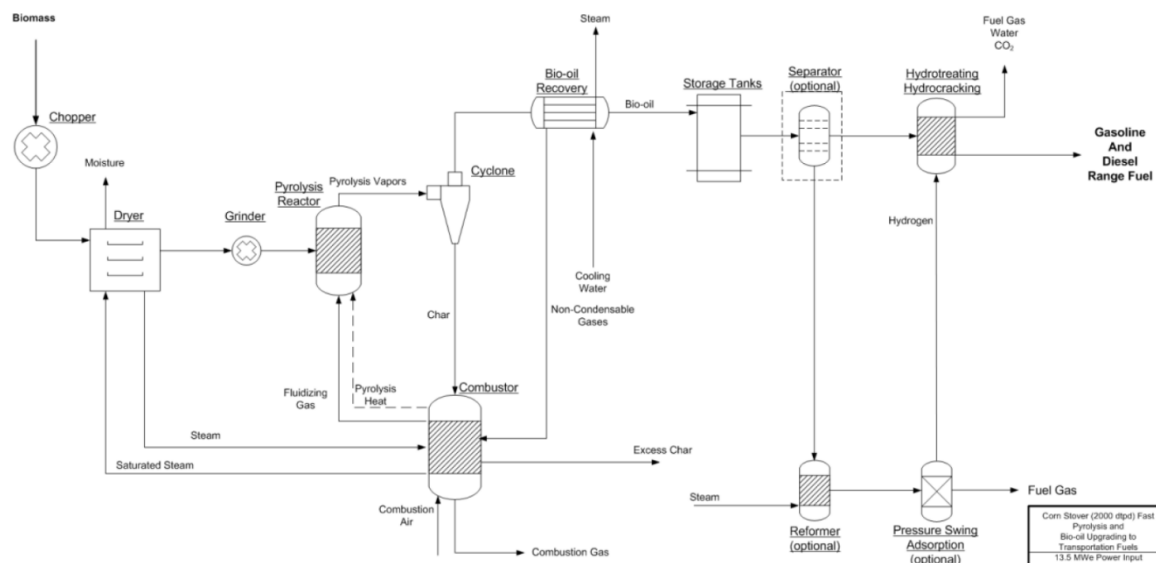

Figure 57. Process flow diagram of biomass pyrolysis with hydrotreating process [169].

To enhance the quality of bio-oil, hydro treatment is applied, using H₂ to reduce oxygen content and convert it into hydrocarbon-rich products such as bio-naphtha. This can be achieved through single-step or two-step configurations, with the latter stabilising the bio-oil before further upgrading for improved results. In some cases, bio-oil is separated into water-soluble and water-insoluble fractions for tailored processing to optimise yield and quality [170].

Table 35. Fast pyrolysis yields from corn stover feedstock [169].

Stream	wt%
Non-condensable gas	14.3
Oil	57.6
Water	8.7
Char/Ash	19.4

The upgraded bio-oil is fractionated into hydrocarbon streams, including bio-naphtha, which can serve as a feedstock for steam crackers to produce olefins and aromatics. Other fractions, such as biodiesel, can be used as transport fuels. Despite its potential, the process faces challenges, including high energy and H₂ demand, as well as catalyst stability and resistance to fouling. Continued advancements in catalysts and H₂ production are critical to addressing these limitations. Table 36 summarises the key inputs, outputs and CAPEX for producing bio-naphtha via pyrolysis.

Table 36. Mass and energy flows of pyrolysis and upgrading for bio naphtha production. Adapted from Wright et al. [169].

	Mass in (kt)		Mass out (kt)	
Mass	Corn stover (15 wt% moisture content)	600	Naphtha	75
	H ₂	27	Diesel	75
			Non condensable gas	309
			Wastewater	52
			Char/Ash	116
Energy	Energy in (TJ/a)		Energy out (TJ/a)	
	Cooling water	n.a.	Electricity	0.33
Economic	CAPEX including product purification section (Million EUR)		Basis year	
	280		Corrected to 2023 using CEPCI index	

• Fischer-Tropsch

Biomass can be converted to liquid hydrocarbons via syngas (which is a mixture of carbon dioxide, carbon monoxide and H₂), through the FT process. Although FT technology has traditionally been associated with the production of fuels such as diesel, kerosene, and gasoline, its potential for generating bio naphtha as a renewable feedstock for petrochemical applications is attracting increased attention. In this context, biomass gasification serves as the initial step, providing a renewable source of syngas that is subsequently converted into FT liquids (see Figure 58).

Figure 58. Block flow diagram of biomass based Fischer-Tropsch process [171].

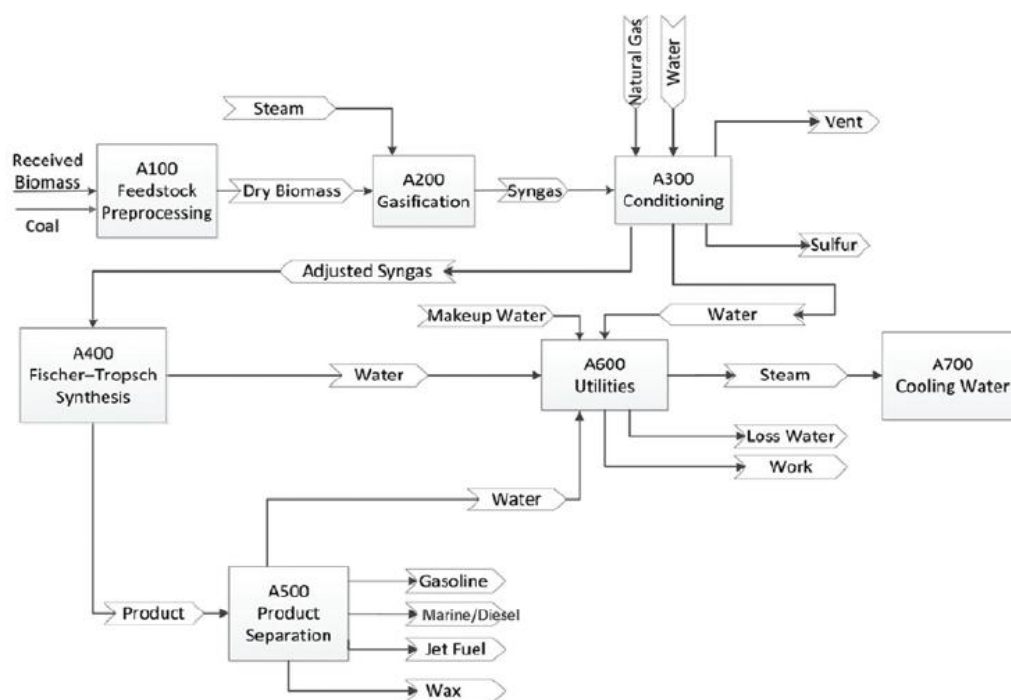

The FT process involves the catalytic conversion of syngas into long-chain hydrocarbons. This reaction takes place in the presence of metal catalysts, typically cobalt or iron, under elevated temperatures ranging from 200 to 300°C and pressures between 20 and 50 bar. The distribution of products from this process is influenced by reaction conditions, like temperature, pressure, residence time, and carbon to H₂ ratio, and catalyst properties and follows the Anderson-Schulz-Flory distribution [172] (see Figure 59); which predicts a mixture of paraffins, olefins, and oxygenates. By carefully adjusting the process parameters, it is possible to target specific product ranges, including naphtha in the FT process.

FT liquids can be separated into distinct fractions. One of these fractions is naphtha, composed of light hydrocarbons in the C₅ to C₁₀ range, which is suitable for use as a feedstock in steam crackers for olefin and aromatic production. Other fractions include middle distillates, such as diesel and kerosene, and heavier hydrocarbons like waxes and lubricants. While most research has historically focused on FT middle distillates for fuel applications, there is growing interest in optimising the process specifically for naphtha production. Diverse studies [173], [174], [175], [176] have explored several approaches, including the development of catalyst formulations and reactor designs to enhance the production of light hydrocarbons, the identification of operating conditions that favour shorter hydrocarbon chains, and the integration of FT processes into biorefineries to improve yields and reduce costs.

The advantages of FT-derived bio-naphtha lies with its high purity and bio-based nature. Bio-naphtha can serve as a sustainable feedstock for olefin production in steam crackers, enabling the production of ethylene, propylene, and BTX (benzene, toluene, and xylene). FT-derived bio-naphtha can be a direct replacement for fossil-based naphtha in steam crackers, thereby offering a viable alternative to fossil-based naphtha. Furthermore, FT-derived bio-naphtha is typically free of sulphur and other impurities, making it a highly versatile and desirable feedstock for petrochemical applications. Table 37 summarises the key inputs, outputs, and economics for producing bio naphtha via Fischer Tropsch.

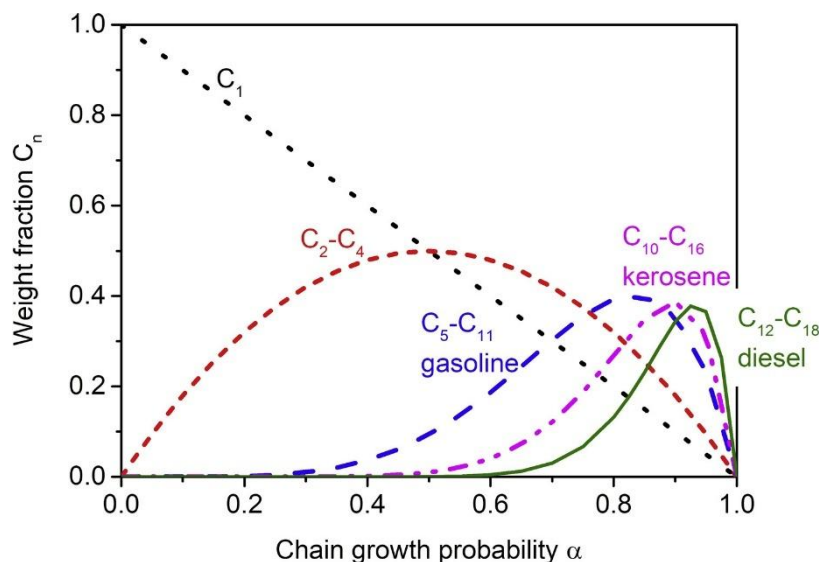

Figure 59. Anderson-Schulz Flory distribution for the FT process.

Table 37. Mass, energy and economic characteristics of Fischer Tropsch process. Adapted from Tan et al [171].

	Mass in (kt)		Mass out (kt)	
Mass	Woody biomass (LHV = 18,27 MJ/kg)	759	Naphtha	53
	Catalyst	2.4	Kerosene	63
	Amine make-up	0.0001	Diesel	29
	Boiler feed water	152	Wax	19
	Combustion air	348	Vent gas (99.9 wt% CO ₂)	893
			Ash	28
			Wastewater	177
Energy	Energy in (TJ/a)		Energy out (TJ/a)	
	Cooling water	97	Electricity	0.03
Economic	CAPEX including product purification section (Million EUR)		Basis year	
	841		Corrected to 2023 using CEPCI index	



ANNEX F. BIOMASS AVAILABILITY IN THE TCR

In this chapter, the availability of biogenic waste in the trilateral region of Netherlands, Germany and Belgium is discussed. The different types of biogenic waste within each category are identified. The report considers the categorisation of biomass feedstocks as sugar-based, oil-based, lignocellulosic and other organic wastes & residues. The potential availability of only second-generation options like lignocellulosic and other organic wastes & residues are considered for biobased production in this study due to concerns related to food security, competition for arable land, and ethical considerations. Thus, the focus is set on feedstock categories listed under the Renewable Energy Directive (REDII) [177], [178]. While this directive refers to feedstocks that are eligible for biofuels production they are also considered as potential feedstock for the chemical industry.

Feedstocks to produce basic chemicals can be classified based on their origin, as first generation, second generation and third generation feedstocks. Third generation (3G) feedstocks refer to emerging resources, mainly aquatic biomass and are not considered in this study, due to the potential uncertainty. First-generation (1G) feedstocks are derived from food and feed crops. These feedstocks have traditionally been mainly used in biofuel production and serve as raw materials for the chemical industry. They are typically rich in fermentable sugars or oils, making them suitable for producing bioethanol, biodiesel, and other platform chemicals. 1G feedstocks can be broadly classified into two categories:

- **Sugar-based crops:** These crops are rich in carbohydrates that can be readily converted into fermentable sugars for example for alcohols production.
- **Oil-based crops:** These crops contain high levels of triglycerides, which can be processed into biodiesel or used as chemical feedstocks for the production of oleochemicals.

In Europe, corn, cereals and sugar beet have been the primary sugar-based feedstock for bioethanol production due to its high yield and suitability for the European climate [179]. The EU imports bioethanol, including sugarcane-based ethanol from countries like Brazil and corn-based ethanol from the United States [180]. For oil-based crops, rapeseed oil has been widely cultivated and used for biodiesel production, particularly in countries such as Germany and France [179]. Soybean is cultivated primarily in Italy, France, and Romania, and soybeans contribute to biodiesel production and serve various industrial applications. While soybean oil has been used for biofuels production; RED II explicitly identifies soybean oil and palm oil as high indirect land use change (ILUC) risk [177]. Sunflower is grown extensively in France, Spain, and Romania, sunflower oil is mainly used in the food industry, with a smaller share directed toward biodiesel production. Imported oil-based feedstocks include palm oil from Southeast Asia, mainly from Indonesia and Malaysia [181], [181], and soybean oil from North and South America, both of which are used in biofuels and chemical applications. Although first-generation feedstocks benefit from established supply chains, their use raises concerns related to food security, competition for arable land, and ethical considerations. These challenges make them a less viable long-term solution for sustainable chemical production.

Second-generation (2G) feedstocks consist of non-food biomass sources that provide a more sustainable alternative to first-generation feedstocks by avoiding direct competition with food production. These materials include:

- Lignocellulosic biomass, such as agricultural and forestry residues including straw, wood chips, and sawdust. These materials are widely available in Europe, particularly in countries with large forestry industries such as Sweden, Finland, and Germany [80], [81], [82].
- Other organic wastes & residue feedstocks (non-oil based), which include municipal solid waste and industrial residues.

- Other organic wastes & residue feedstocks (oil & fat based), which include used cooking oils, crude tall oil and tallow [182]. In Europe, the collection and processing of used cooking oils have expanded, especially in countries such as the Netherlands and the UK, where waste-to-biofuel initiatives are well established [82], [90].

The 2G-biomass is distinguished as lignocellulosic, other organic wastes & residues (non-oil based) and other organic wastes and residues (oil & fat based) due to the wet and/or readily decomposable and oleochemical nature of certain biogenic materials. Biochemical processes like anaerobic digestion suit organic residues & waste (non-oil based) better while organic residues & waste (oil & fat based) are better suited for hydrotreatment based upgradation.

Various subtypes exist within this category. To maintain consistency and comparability with other studies, these feedstocks have been classified into specific categories. The selected categories include agricultural residues, manure, biowaste, lignocellulosic crops, wood, forestry residues, secondary forestry residues, municipal solid waste (MSW), and waste or residual oils [82] (Table 38).

Table 38. Biomass classification for the evaluation of bio-based chemical value chains [82].

Type of Biomass		Description
Lignocellulosic biomass	Agricultural Residues	Remnants of crops left after harvesting, such as wheat straw and corn stover.
	Lignocellulosic Crops	Crops cultivated for their lignocellulosic content, such as switchgrass and miscanthus, suitable for biofuel or bio-based product production.
	Wood	Biomass derived from trees, commonly available in forms such as logs, chips, or pellets.
	Forestry Residues	Byproducts from forestry activities, including branches, bark, and treetops.
	Secondary Forestry Residues	Waste generated during timber processing, such as sawmill residues.
Other organic wastes & residues (non-oil based)	Manure	Organic waste from livestock, including cows, pigs, and poultry, that can serve as biomass.
	Biowaste	Organic material from food scraps, vegetable waste, and residues from kitchens or markets.
	Municipal Solid Waste (MSW)	Household and commercial waste collected by municipalities that contains organic components suitable for biomass applications.
Other organic wastes & residues (oil based)	Waste/residuals oils	Byproducts such as used cooking oils and animal fats originating from industrial or commercial activities.

Second-generation feedstocks support waste valorisation and contribute to circular economy objectives by utilising materials that would otherwise be discarded. Their use helps to reduce environmental impact and reliance on fossil-based raw materials.

Biomass availability

There are several studies in the literature which assess the biomass potential in Europe like the European commission [83], [84], [85], Oak Ridge National laboratory [86], bioenergy KDF [87] and Concawe study [88], [89]. The Concawe study was used in this write-up as it had a better disaggregated availability data for the trilateral region with different biomass types. The Concawe study,[90] supported by Borzęcka et al.[91], projects an increase in total bioenergy potential from 175 Mtoe in 2020 to a range of 210 to 320 Mtoe by 2030 and 350 to 535 Mtoe by 2050 in Europe. In terms of biomass availability, this corresponds to 437.5 million dry tons (MDT) in 2020, increasing to 525 MDT to 800 MDT by 2030 and 875 MDT to 1,338 MDT by 2050. By 2050, the study estimates that 360 Mtoe annually (900 MDT) will be required. There are several studies in the literature which assess the biomass potential in Europe like the European commission [83], [84], [85], Oak Ridge National laboratory [86], bioenergy KDF [87] and Concawe study [88], [89]. The Concawe study was used in this write-up as it had a better disaggregated availability data for the trilateral region with different biomass types. The Concawe study,[90] supported by Borzęcka et al. [91], projects an increase in total bioenergy potential from 175 Mtoe in 2020 to a range of 210 to 320 Mtoe by 2030 and 350 to 535 Mtoe by 2050 in Europe. In terms of biomass availability, this corresponds to 437.5 million dry tons (MDT) in 2020, increasing to 525 MDT to 800 MDT by 2030 and 875 MDT to 1,338 MDT by 2050. By 2050, the study estimates that 360 Mtoe annually (900 MDT) will be required, with an additional 15 Mtoe per year expected to be imported. Three scenarios have been analysed in the Concawe study:

- Low biomass mobilisation (Scenario 1 - Low)
- Improved mobilisation in selected countries due to improvements in cropping and forest management practices (Scenario 2 - Medium)
- Enhanced availability through research and innovation (R&I) measures as well as improved mobilisation due to improvements in cropping and forest management practices (Scenario 3 - High)

The main assumptions for the three scenarios is shown in Table 39 and the detailed assumptions of each scenario can be found in the Concawe report [89].

Table 39. Main assumptions of the three scenarios in the Concawe report [89].

Feedstock type		Scenario 1 (low)	Scenario 2 (medium)	Scenario 3 (High)
Agriculture	Removal rate of field residues	40 %	45 %	50 %
	Use of pruning	5 %	20 %	50 %
	Moderate yield increases in perennial lignocellulosic crops in unused, degraded and abandoned land	1 %	1 %	2 %
	Share of unused, degraded and abandoned land for dedicated crops, excluding biodiversity rich land and land with high carbon stocks (current share of unused, degraded and abandoned land for dedicated crops: there are no official statistics – only at experimental and demonstration scale)	25 %	50 %	75 %

Forestry	Stemwood used for energy purposes (current stemwood for energy: 45 %)	25 %	30 %	50 %
	Primary forestry residues availability for energy production	40 %	50 %	60 %
	Secondary forestry residues and post-consumer wood availability for energy	55 %	60 %	65 %
Wastes	Bio-waste used for energy production (current collection for bioenergy: 40-45 %)	60 % in 2030 (65 % in 2050) of bio-waste is recycled and 40 % in 2030 (35 % in 2050) is separately collected and available for bioenergy	50 % in 2030 (55 % in 2050) of bio-waste is recycled and 50 % in 2030 (45 % in 2050) is separately collected and available for anaerobic digestion	40 % in 2030 (45 % in 2050) of bio-waste is recycled and 60 % in 2030 (55 % in 2050) is separately collected and available for anaerobic digestion

From the three scenarios the study analysed firstly the sustainable biomass availability for all markets and then estimated the amount that can be available for bioenergy after excluding the so far known demand from non-energy sectors. The main assumption of biomass allocation for bioenergy is shown in Table 40 and the detailed allocation assumptions can be found in the Concawe report [88].

Table 40. Main assumptions for biomass allocation for bioenergy [88].

Feedstock type		Bioenergy allocation assumption
Agriculture	Cereal straw	Cereal straw is being used for animal feed, animal bedding and mushroom growing. The competing use was calculated based on livestock numbers and mushroom production levels. The estimated potential in the previous section is reduced based on demand from non-energy uses that is projected by Concawe [90] and statistics from JRC [183].
	Maise and oil crop residues	An average of 20 % share is allocated to biobased markets both for 2030 and 2050.
	Manure	All the estimated quantities for manure are assumed to be available for bioenergy production
Forestry	Stem wood	Assumes 25 % of stem wood being used for energy purposes as fuelwood in the Low scenario, 30 % in the medium and 50 % in the high scenario
Wastes	Bio-wastes	According to the Circular Economy Package, 55 % of municipal waste needs to be re-used and recycled by 2025, 60 % by 2030, and 65 % by 2035. The amount of municipal waste landfilled must be reduced to 10 % or less of the total amount of municipal waste generated by 2035. This study applied the above rates to 2030 and to 2050 (the 65 % announced for 2035) in the Low Scenario
	Used cooking oil	2030: Household collection rate: 15 %; Professional collection rate: 90 % and 2050: Household collection rate: 45 %; Professional collection rate: 90 %

Most biomass availability assessments in Europe have primarily focused on bioenergy applications, with few studies evaluating its potential use for the chemical industry such as the Renewable Carbon initiative report [184]. This is because there has been policy push for the bioenergy sectors and not for chemicals. Currently, 2G feedstocks like woody biomass is used for electricity and heating purposes and used cooking oil & animal fats for transport applications, which may cause competition for feedstocks in the future [185], [186].

Despite these challenges, there are opportunities for synergies between the chemical and transport sectors that could improve biomass utilisation efficiency. Use of biofuels in the chemical industry could improve further mobilisation of feedstocks and biorefineries could serve both the transport and chemical industry derisking the market potential and improving the economics.

- **The Netherlands**

The biogenic waste potential of the Netherlands is estimated to be around 8 Mio. t based on the Concawe scenario 3 (2030 High scenario) [88]. About 4.84 Mio. t are estimated to be lignocellulosic waste and 3.14 Mio. t are other fractions like biogenic fraction of municipal solid waste, animal waste, and food waste.

Table 41. Estimated biomass availability in the Netherlands by 2030 based on [88].

Feedstock type		Estimated availability in 2030 (kt dry biomass)		
		Low	Medium	High
Lignocellulosic biomass	Secondary Agricultural residues	968	1,113	1,403
	Lignocellulosic Crops	352	352	1,056
	Secondary forest residues (incl. post-consumer wood)	596	14	846
	Cereal straw	475	475	644
	Stem wood	183	220	440
	Wood waste	92	126	165
	Maise stover	128	128	140
	Paper cardboard	30	42	55
	Agricultural pruning	18	22	48
	Primary forest residues	9	12	17
	Oil crop residues	16	16	19
Other organic waste & residues (non-oil based)	MSW (biogenic fraction)	1,540	2,156	2,773
	Animal & mixed food waste	120	165	217
	Vegetable waste	83	115	150
	Manure	0	0	0
Other organic waste & residues (oil-based)	Used cooking oil	58		

Table 41 highlights the projected distribution of 2G biomass feedstocks in the Netherlands for 2030 by feedstock type. Secondary agricultural residues are expected to be the highest contributor comprise about 29 % of the total estimated dry lignocellulosic biomass feedstock, followed by lignocellulosic crops which will account for around 22 %. Among the other organic wastes & residues, 88 % of the contribution is projected to come from the biogenic fraction of MSW. These proportions illustrate the relative importance of the agriculture sector and municipal solid waste for future biomass applications in the Netherlands.

- **Germany**

The biogenic waste potential of Germany is estimated to be around 99 Mio. t based on the Concawe scenario 3 (2030 High scenario) [88]. About 85.8 Mio. t are estimated to be lignocellulosic waste and 13.2 Mio. t as other fractions like biogenic fraction of municipal solid waste, animal waste and food waste.

Table 42. Estimated biomass availability in Germany by 2030 based on [88].

Feedstock type		Estimated availability in 2030 (kt dry biomass)		
		Low	Medium	High
Lignocellulosic biomass	Cereal straw	21,967	23,166	26,762
	Stem wood	10,540	15,177	25,296
	Secondary forest residues (incl. post-consumer wood)	7,988	10,458	11,329
	Lignocellulosic Crops	2,504	5,009	7,514
	Primary forest residues	4,640	5,950	7,320
	Secondary Agricultural residues	3,696	4,251	5,360
	Maise stover	1,394	1,534	1,534
	Wood waste	181	248	325
	Agricultural pruning	115	158	300
	Oil crop residues	48	58	58
	Paper cardboard	10	14	18
Other organic wastes & residues (non-oil based)	MSW (biogenic fraction)	4,129	5,678	7,433
	Manure	12,001	14,402	5,194
	Vegetable waste	240	330	432
	Animal & mixed food waste	102	140	184
Other organic wastes & residues (oil-based)	Used cooking oil	578		

Table 42 highlights the projected distribution of 2G biomass feedstocks in Germany for 2030 by feedstock type. Agricultural residues from cereal straw, maise stover and secondary residues are expected to be the highest contributor comprise about 39 % of the total estimated dry lignocellulosic biomass feedstock, followed by stem wood which will account for around 29 %. Among the other organic wastes & residues, 56 % of the contribution is projected to come from the biogenic fraction of MSW and 39 % from manure. These proportions illustrate the relative importance of the agriculture sector for future biomass applications in Germany.

- **Belgium**

The biogenic waste potential of Belgium is estimated to be around 9.3 Mio. t based on the Concawe scenario 3 (2030 High scenario) [88]. About 6.14 Mio. t are estimated to be lignocellulosic waste and 3.18 Mio. t as other fractions like biogenic fraction of municipal solid waste, animal waste and food waste.

Table 43. Estimated biomass availability in Belgium by 2030 based on [88].

Feedstock type		Estimated availability in 2030 (kt dry biomass)		
		Low	Medium	High
Lignocellulosic biomass	Cereal straw	1,078	1,078	1,380
	Stem wood	510	612	1,225
	Secondary forest residues (incl. post-consumer wood)	679	130	963
	Lignocellulosic Crops	314	314	944
	Secondary Agricultural residues	593	681	859
	Maise stover	249	249	274
	Primary forest residues	86	108	156
	Wood waste	77	106	139
	Paper cardboard	71	97	128
	Agricultural pruning	26	31	68
	Oil crop residues	0	0	0
Other organic wastes & residues (non-oil based)	Manure	2,209	2,651	2,627
	MSW (biogenic fraction)	209	287	376
	Vegetable waste	76	105	138
	Animal & mixed food waste	21	29	39
Other organic wastes & residues (oil-based)	Used cooking oil	70		

Table 43 highlights the projected distribution of 2G biomass feedstocks in Belgium for 2030 by feedstock type. Agricultural residues are expected to be the highest contributor comprise about 41 % of the total estimated dry lignocellulosic biomass feedstock, followed by lignocellulosic crops and stem wood which will account for around 35 %. Among the other organic wastes & residues, 83 % of the contribution is projected to come from manure. These proportions illustrate the relative importance of the agriculture residues and lignocellulosic crops for future biomass applications in Belgium.

ANNEX G. PLASTIC WASTE BASED PATHWAYS FOR THE PRODUCTION OF OLEFINS AND AROMATICS

Base chemicals such as olefins (ethylene, propylene, and butadiene), BTX (benzene, toluene, xylene, and other aromatics), and methanol are essential components of the chemical industry, playing a key role in the production of a wide range of materials and products. The production of base chemicals such as olefins and aromatics predominantly depends on fossil feedstocks, resulting in significant CO₂ emissions due to the energy-intensive processes and scope-3 emissions involved. To address these environmental challenges, the chemical industry is exploring alternative pathways to produce these chemicals with a lower carbon footprint. This report examines the base chemical production routes from plastic waste.

Plastic waste recycling technologies can be classified as physical recycling based and chemical recycling based. Physical recycling technologies transform plastic waste into new raw materials or products without altering the chemical structure of the polymers. Plastic waste can be physically recycled using mechanical or dissolution recycling (as shown in Figure 60).

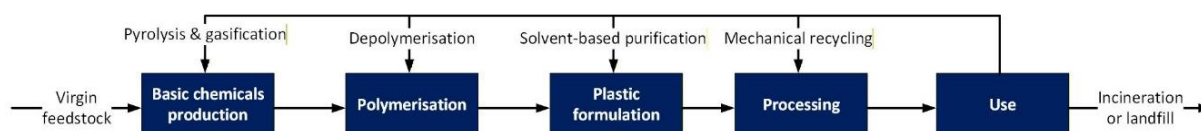

Figure 60. Ways of recycling plastic waste (adapted from CE Delft report [187]).

The mechanical recycling process involves analysis, sorting, shredding, washing, and melting the plastic, followed by extrusion to create new granules. Mechanical recycling may not be suitable for all types of plastic waste, especially mixed or contaminated materials [187]. While generally considered efficient, mechanical recycling usually impacts the quality of recycled materials, requiring additional processes to maintain desired properties. The quality will always change (go down) because it is not a mono-stream (i. e., different polymer types and colours present) that is recycled this way. In addition, each time plastic is mechanically recycled, the polymer chains within it break down, leading to a decrease in its overall quality. Due to this quality degradation, most plastics can only be mechanically recycled a limited number of times, depending on the target use-case after recycling. If a very low target is set, it might still be possible for a higher number of times for mechanical recycling.

All thermoplastics like polyethylene, polypropylene, polystyrene, polyvinyl chloride etc. can be mechanically recycled to the same product. Thermoset plastics are not easy to mechanically recycle to the same product as they cannot be melted and reprocessed. Mechanical recycling of thermosets involves grinding or shredding waste into particles, which can then be used as a filler or additive in new products.

In dissolution, solvolysis, or solvent-based extraction, the plastic waste is dissolved in a solvent to remove additives and contaminants from the waste mixture. The polymer structure itself is not affected in the process (except for solvolysis) and therefore the polymers are extracted as output in the recycling technology. In solvolysis, the polymer can be broken down by the solvent as well. It can be used for recycling products from other sectors such as the electronics, automotive sectors, or for composite materials. Currently, solvolysis is used to recycle expanded polystyrene (EPS), which is commonly used as an isolation material in the construction sector and has been processed with flame retardants [187]. The EPS is separated from the brominated flame retardants, after which the polymers are extracted

from the solvent and processed into clean polystyrene (PS). In the case of EPS, a homogeneous feedstock stream is required for the solvolysis process. This means that a clean plastic stream with less than 10 % contamination is needed, in the case of solvolysis for EPS [188].

Chemical recycling on the other hand converts plastic waste into petrochemical feedstocks (like naphtha or syngas) and base chemicals (like ethylene, propylene, benzene and xylene). It complements mechanical recycling by enabling the recycling of different streams of plastic waste that cannot otherwise be recycled, particularly mixed and contaminated plastics, into virgin-like raw materials or monomers. The three types of chemical recycling technologies are depolymerisation, gasification, and pyrolysis.

In depolymerisation, polymers are broken down into monomers and/or oligomers using chemical reactions and/or heat. These monomers and/or oligomers can be used to rebuild new polymers of higher quality or purity, as polymer chain lengths can be restored and contaminants can be removed. For example, depolymerisation can be used for devulcanisation of rubber or to directly rebuild recycled PET from waste PET. In this case DKR 328-1 (sorted PET) is first pre-treated to remove impurities, moisture, and volatile components from the PET flakes. Next, the polyethylene terephthalate (PET) molecules are depolymerised into monomers like p-xylene and ethylene glycol. Finally, the monomers are re-polymerised into PET polymers, which are granulated and stored. Depolymerisation is often limited to certain types of polymers (like condensation polymers) and may require specific catalysts or conditions.

Table 44: Example of plastic waste recycling technologies, their input and output.

Technology		Feedstock (Input)	Product (Output)
Physical recycling	Mechanical recycling	Sorted plastic waste	Recycled plastic granules
	Solvent-based extraction	Expanded Polystyrene (pre-sorted)	Polystyrene (polymer)
Chemical recycling	Depolymerisation	DKR 328 (PET)	p-xylene and ethylene glycol
	Pyrolysis	DKR 310 (foils), DKR 323 (mixed polyolefins), DKR 324 (polypropylene), etc.	Pyrolysis oil
	Gasification	DKR 350 (mixed plastics), DKR 310 (foils), DKR 323 (mixed polyolefins), DKR 324 (polypropylene), etc.	Syngas (syngas can be converted to chemicals & fuels)

The most mature chemical recycling technologies are gasification and pyrolysis. In the gasification process, plastic waste is heated to very high temperatures under low oxygen conditions using gasifying agents (like steam and/or oxygen), typically resulting in a gaseous output named syngas that can be used as fuel or building block for chemicals and fuels. Pyrolysis involves heating the plastic waste, at high temperatures (typically 300 °C to 800 °C) in the absence of oxygen. Pyrolysis produces a range of products including pyrolysis oil (a liquid fuel), gases (like methane and ethane), and a solid residue (char). These chemical recycling technologies can be used for processing mixed and contaminated plastic waste streams that are difficult to recycle mechanically or with solvent-based processes and can be used to generate fuel or feedstock for the petrochemical processes. Polyolefins (like polyethylene, polypropylene) and other plastics that can be thermally degraded without oxygen are best suited for the pyrolysis process, while gasification can be used for a wide range of plastics that are not suitable for pyrolysis. PVC is not preferred in gasification or pyrolysis processes as chlorine is highly corrosive and

cracking plants are not common within Europe. The other product streams produced during plastic waste pyrolysis like diesel and heating oil can also be steam cracked to produce olefins [190], however, the heavy steam cracking plants are not common within Europe. After steam cracking, the hydrocarbon mixture undergoes downstream purification to remove impurities (like CO₂, H₂S and water) and complex separation processes (like high pressure cryogenic distillation and extractive distillation) to separate the individual components into high-purity product streams, which can then be used to make new polymers.

Table 45: Mass, energy and economic characteristics of plastic pyrolysis process [166].

Note: For energy positive sign means energy need and negative sign means energy production. The capacity of 5,000 kt/a plastic waste is used such as to produce about 1,000 kt/a naphtha, which is equivalent to the 1/3rd naphtha demand in the Port of Rotterdam. Such an industrial scale pyrolysis plant does not exist.

	Mass in (kt)		Mass out (kt)	
Mass	Off gas combustion and catalyst regeneration air for heating	39,068	Diesel	1,456
	H ₂	16	Naphtha	1,055
	Sodium hydroxide	50	Vacuum gas oil	1,333
	Plastic waste (DKR 329 and DKR 324)	5,000	Flue gas	40,341
	Process steam	100	Waste water	50
	Energy in (TJ/a)		Energy out (TJ/a)	
Energy	Cooling water	3,385	Low pressure steam	-4,872
	Electricity	8	Medium pressure steam	-2,986
			High pressure steam	-30,966
Economic	CAPEX including product purification section (Million EUR)		Basis year	
	1,036		Corrected to 2023 using CEPCI	

As seen in Table 45, the typical naphtha yield from the plastic pyrolysis is only 16 %. Thus, significant quantities of plastic waste will be required if only naphtha is used for olefin production. The other byproducts of plastic pyrolysis like diesel and vacuum gas oil can also be steam cracked to produce olefins with yields as shown in Table 46. Such heavy oil crackers or adapting the current steam crackers to handle a wider range of hydrocarbons will be crucial to increase the material usage efficiency and reduce the quantity of plastic waste required to produce olefin.

Table 46: Yield comparison of naphtha, diesel and vacuum gas oil steam cracking processes (typical example) [190].

	Naphtha cracking (high-severity)	Diesel cracking	Vacuum gas oil cracking
Steam dilution (kg/kg)	0.5	0.8	1
Residence time (sec)	0.493	0.32	0.3
Yield (wt%)			
H ₂	0.99	0.71	0.68
CO	0.06	0.01	0.01
CO ₂	0	0.01	0.01
H ₂ S	0	0	0
CH ₄	16.9	10.58	11.08
C ₂ H ₂	0.64	0.38	0.6
C ₂ H ₄ (Ethylene)	30.25	25.93	25.98
C ₂ H ₆	4.32	2.82	2.81
C ₃ H ₄	0.81	0.63	0.97
C ₃ H ₆ (Propylene)	13.63	14.07	16.02
C ₃ H ₈	0.37	0.37	0.42
C ₄ H ₄	0.18	0.12	0.04
C ₄ H ₆	4.2	5.73	8.03
C ₄ H ₈	3.11	3.61	4.14
C ₄ H ₁₀	0.17	0.05	0.06
Benzene	8.32	5.44	5.64
Toluene	3.4	3.49	2.73
Xylenes	1.14	0.92	0.46
Ethylbenzene	0.44	0.37	0.34
Styrene	1.44	1.18	1.12
Pyrolysis gasoline	5.25	7.28	6.91
Pyrolysis fuel oil	4.38	16.3	11.95

Table 47: Mass, energy and economic characteristics of naphtha steam cracking process [166].

Note: For energy positive sign means energy need and negative sign means energy production, Solvent are n-formyl morpholine, dimethyl formamide and n-methyl pyrrolidone.

	Mass in (kt)		Mass out (kt)	
	Mass	Naphtha	3,000	Ethylene
Steam		1,500	Propylene	497
Combustion air		23,311	Acetylene	18
Sodium hydroxide		18	Butene mixture	93
Dilution water		147	Butadiene	116
Solvent		0.14	C9+ stream	224
Make-up water		1,5	Benzene	689
H ₂		1.17	C7+ stream/Pygas tail	279
Pygas import		372	Nonaromatic stream	295
Reformate import		417	Propane rich fuel gas	11
Wash water		6.4	Vinyl acetylene	5
			Flue gas	23,984
		Waste water	1,683	
	Energy in (TJ/a)		Energy out (TJ/a)	
	Energy	Low pressure steam	5,208	Medium pressure steam
Cooling water		26,469	High pressure steam	-5,970
Chilled water		997	Very high-pressure steam	-1,714
Electricity		7,315		
Economic	CAPEX including product purification section (Million EUR)		Basis year	
	1,486		Corrected to 2023 using CEPCI	

Plastic waste steam gasification + syngas to methanol + methanol to olefin (Mixed plastic waste mainly)

Unsorted plastic waste (like mixed municipal plastic waste) can be converted to olefins via steam gasification and methanol to olefin process. Gasification produces syngas (a mixture of CO and H₂) from plastic. The syngas, among other uses, can be converted into basic chemicals such as methanol. The steam gasification occurs at 800 °C to 1,000 °C in a fluidised bed reactor with sand bed material near atmospheric pressure. The raw syngas undergoes cleaning to remove impurities (like entrained catalyst, water, tar, acid gases). The hydrogenation of the clean syngas to methanol occurs in a tubular reactor at 69 bar and 255 °C, over a Cu-ZnO-Al₂O₃ based catalyst.

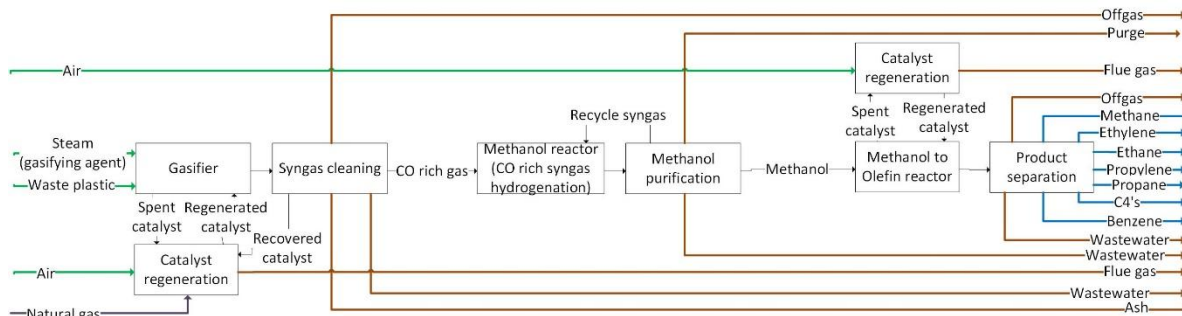

Figure 62. Block flow diagram of plastic to olefin via methanol process [189].

Note that that in this route, external hydrogen or excess CO₂ removal from syngas is not required, as the syngas has a H₂/(CO+CO₂) ratio above 2 in the input gas to the methanol reactor. The methanol produced (99.9 wt% pure), after going through a distillation process to remove light gases and water, is sent to the MTO fluidised bed reactor operating at 30 bar and 450 °C. The MTO process produces ethylene and propylene along with other by-products (like methane, ethane, propane, C4's, benzene). The product mixture is separated into high purity products using a series of separation processes (like dehydration, cryogenic distillation, extractive distillation).

Table 48: Mass, energy and economic characteristics of plastic waste gasification followed by syngas to methanol process [166].

Note: For energy positive sign means energy need and negative sign means energy production, Solvent is ethylene diamine tetra acetic acid and catalyst is silica.

	Mass in (kt)		Mass out (kt)	
	Mass	Plastic waste (DKR 350)	310	Methanol
Water		356	Ash	12
Natural gas for heating		66	Flue gas	4,022
Combustion air		3,850	Waste water	244
Catalyst make-up		1		
Solvent		104		
Energy	Energy in (TJ/a)		Energy out (TJ/a)	
	Low pressure steam	1,792	Medium pressure steam	-1,389
	Cooling water	2,617	High pressure steam	-615
	Electricity	745		
Economic	CAPEX including product purification section (Million EUR)		Basis year	
	530		Corrected to 2023 using CEPCI	

Table 49: Mass, energy and economic characteristics of methanol to olefin process [166].

Note: For energy positive sign means energy need and negative sign means energy production, catalyst is SAPO-34. The capacity of 2,300 kt/a methanol is used such as to produce about 300 kt/a ethylene, which is equivalent to the 1/3rd ethylene production in the Port of Rotterdam. Such an industrial scale methanol to olefin plant does not exist.

	Mass in (kt)		Mass out (kt)	
	Mass	Methanol	2,300	Methane
Combustion air		360	Ethylene	314
Catalyst		1	Ethane	9
			Propylene	398
			Propane	74
			C4 (assumed to butene)	106
			C5+ (assumed to be benzene)	80
			Flue gas	386
		Waste water	1,284	
	Energy in (TJ/a)		Energy out (TJ/a)	
	Energy	Low pressure steam	6,500	Medium pressure steam
Cooling water		9,743	High pressure steam	-68
Electricity		1,892		
Economic	CAPEX including product purification section (Million EUR)		Basis year	
	423		Corrected to 2023 using CEPCI	

Plastic waste to aromatics

Plastic waste can be converted into aromatics mainly through two process routes as explained below.

- **Plastic waste pyrolysis + pyrolysis oil catalytic reforming (using sorted polyolefin based plastic waste)**

Sorted plastic waste can be converted to aromatics via low-temperature pyrolysis followed by naphtha catalytic reforming. Plastic is pyrolysed at 300 °C to 500 °C near atmospheric pressure to yield a hydrocarbon mixture containing off-gas, naphtha (hydrocarbon with boiling point ranging from 26 °C to 183 °C), diesel (hydrocarbon with boiling point ranging from 180 °C to 350 °C), heating oil (hydrocarbon with boiling point ranging from 313 °C to 475 °C) and char. The pyrolysis reactor can be operated as a fluidised bed with catalyst regeneration to clean the char from catalyst in a continuous manner. A set of cyclones and cloth filters are used to remove the entrained catalyst from the reactor outlet and the regenerator. During pyrolysis, unsaturated hydrocarbons are formed, and to ensure saturated hydrocarbons, the pyrolysis oil goes through a hydrogenation step. The H₂ can be supplied via water electrolysis. The hydrocarbon mixture is then separated through vacuum distillation to produce naphtha, diesel and vacuum gas oil. The off-gases from the distillation section may contain impurities like H₂S and HCl which can be neutralised with NaOH scrubbing. The naphtha stream (hydrocarbon fraction in the boiling range of 35 °C to 180 °C) can be fed to a catalytic reformer to produce aromatics.

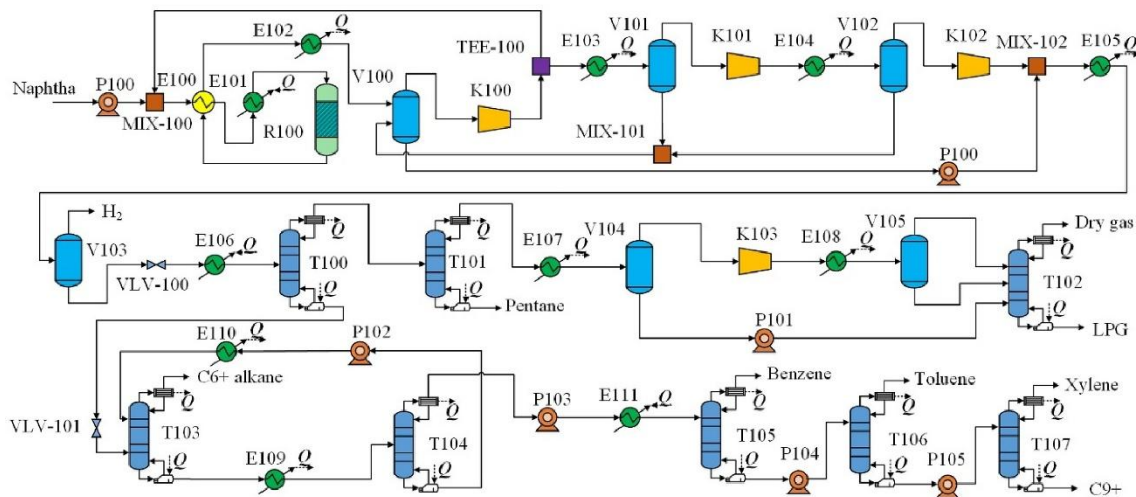

Figure 63. Process flow diagram of naphtha catalytic reformer process [191].

Catalytic reforming is the primary process used to convert naphtha into aromatic hydrocarbons, including benzene, toluene, and xylenes (BTX), which are valuable petrochemical building blocks. This process involves using a catalyst, typically a noble metal like platinum, on an acidic support. In catalytic naphtha reforming, the temperature typically ranges from 450 to 540°C and pressure of approx. 5 bar. These conditions, along with a H₂ atmosphere, facilitate the conversion of naphtha (a mixture of paraffin, naphthene, and aromatics) into high-octane gasoline components and aromatic compounds like benzene, toluene, and xylenes (BTX). A high partial pressure of H₂ is also needed to favour the desired reactions. The main reactions involved are the dehydrogenation of naphthene to aromatics, isomerisation of paraffins, and dehydrocyclisation of paraffins to aromatic. Generally, the Continuous Catalyst Regeneration (CCR) reactor configuration is used, meaning the catalyst is continuously circulated and regenerated to maintain its activity during the process. The benzene yield can be increased using toluene disproportionation and xylene isomerisation reactors, which are not included in the data given below.

Table 50: Mass, energy and economic characteristics of naphtha catalytic reforming process [191].

Note: for energy positive sign means energy need and negative sign means energy production, catalyst is platinum on chlorinated alumina support, the refrigeration need was converted to electricity and cooling water needs using a coefficient of performance of 1.91.

Mass	Mass in (kt)		Mass out (kt)	
		Naphtha	456	H2
			Dry gas	0
			Liquified petroleum gas	20
			Pentane	18
			C6+ alkane	67
			Benzene	24
			Toluene	72
			Xylene	133
			C9+	74

Energy	Energy in (TJ/a)		Energy out (TJ/a)	
	Medium pressure steam	162	Low pressure steam	-234
	High pressure steam	819		
	Fired heat	541		
	Cooling water	870		
	Electricity	118		
Economic	CAPEX including product purification section (Million EUR)		Basis year	
	127		Corrected to 2023 using CEPCI	

As seen in Table 45, the naphtha yield from the plastic pyrolysis is only 16 %. Thus, significant quantities of plastic waste will be required if only naphtha is used for aromatics production. The other byproducts of plastic pyrolysis like diesel and vacuum gas oil can also be converted to naphtha to increase the aromatics yields using a fluidised catalytic cracker as shown in Table 51. Vacuum gas oil fluidised catalytic crackers (FCC) already exist in current refineries to convert heavy fraction of crude oil to more valuable light fractions like olefins and naphtha. The heavy oils can also be steam cracked to produce aromatics with yields as shown in Table 47. Such heavy oil crackers or adapting the current steam crackers to handle a wider range of hydrocarbons will be crucial to increase the material usage efficiency and reduce the quantity of plastic waste required to produce aromatics.

Table 51: Mass and economic characteristics of fluidised catalytic cracker to produce naphtha from heavy oils [192].

Mass	Mass in (kt)		Mass out (kt)	
	Vacuum gas oil	2,393	Light gases	76
			Liquified petroleum gas	362
			Naphtha	1,189
			Light cycle oil	497
			Heavy cycle oil	169
			Coke	99
Economic	CAPEX including product purification section (Million EUR)		Basis year	
	846		Corrected to 2023 using CEPCI	

Plastic waste steam gasification + syngas to methanol + methanol to aromatics (Mixed plastic waste mainly)

Unsorted plastic waste (like mixed municipal plastic waste) can be converted to aromatics via steam gasification followed by the MTA route. Steam gasification occurs in a fluidised bed reactor at 800 °C to 1,000 °C near atmospheric pressure, using sand as the bed material. The resulting raw syngas is cleaned to remove impurities (entrained catalyst, water, tar, and acid gases). The clean syngas is then converted to methanol in a tubular reactor at 69 bar and 255 °C, using Cu-ZnO-Al₂O₃ catalyst.

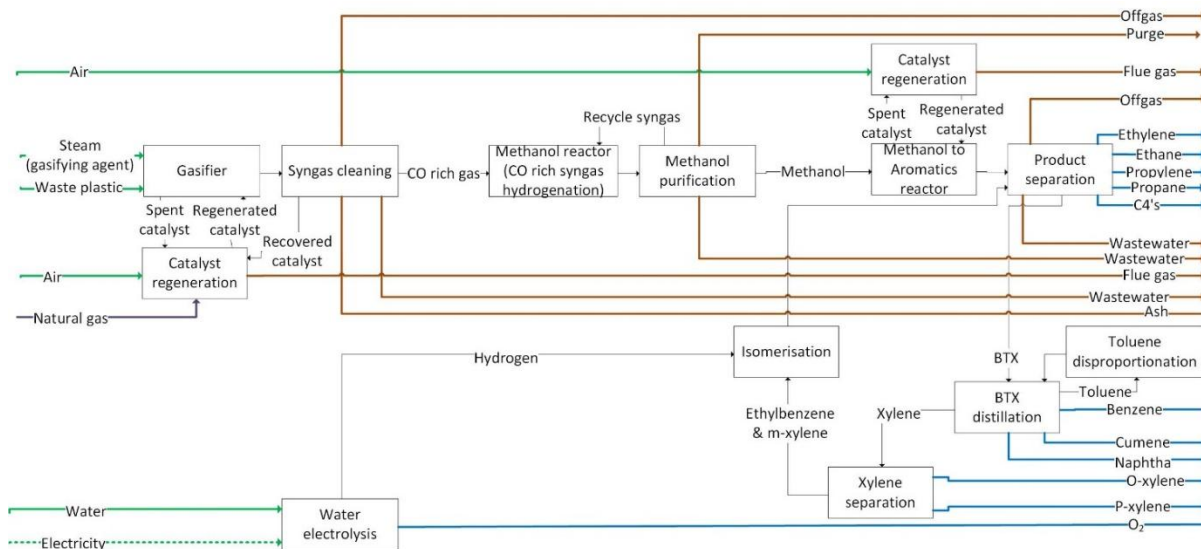

Figure 64. Block flow diagram of plastic waste to aromatics via methanol process [189].

Unlike the biomass and CO₂ routes, this process does not require additional H₂ or acid gas removal as the syngas had a H₂/(CO+CO₂) ratio above 2. The resulting methanol was purified (99.9 wt% pure) via distillation to remove light gases and water. In the second step, methanol is fed into a fluidised bed MTA reactor (60 bar, 450 °C), producing benzene along with by-products like methane, ethane, propylene, propane, C4's, toluene, xylene. To increase the benzene yield, toluene and m-xylene, were further processed using a toluene disproportionation to benzene reactor and a m-xylene isomerisation unit. The final product mixture was separated into high-purity products using a series of advanced separation steps (dehydration, cryogenic distillation, extractive distillation).

Table 52: Mass, energy and economic characteristics of methanol to aromatics process [166].

Note: For energy positive sign means energy need and negative sign means energy production, catalyst is HZM-5. The capacity of 8,800 kt/a methanol is used such as to produce about 500 kt/a benzene, which is equivalent to the benzene production in the Port of Rotterdam. Such an industrial scale methanol to aromatics plant does not yet exist.

Mass	Mass in (kt)		Mass out (kt)	
	Input	Value	Output	Value
	Methanol	8,800	Ethylene	21
	Combustion air	8,733	Ethane	195
	Catalyst	4	Propylene	68
	H ₂	17	Propane	641
			C4 (assumed to butene)	921

		Cumene	240	
		Naphthalene	32	
		O-xylene	5	
		P-xylene	972	
		Benzene	535	
		Flue gas	9,012	
		Waste water	4,914	
Energy	Energy in (TJ/a)		Energy out (TJ/a)	
	Medium pressure steam	4,493	Low pressure steam	-12,020
	Cooling water	21,065	High pressure steam	-15
	Electricity	5,122		
Economic	CAPEX including product purification section (Million EUR)		Basis year	
	3,676		Corrected to 2023 using CEPCI	

ANNEX H. PLASTIC WASTE AVAILABILITY IN THE TCR

In this chapter, the availability of plastic waste as alternative feedstock in the trilateral region of Netherlands, Germany and Belgium is discussed. The different types of waste within each category are identified and the production potential of the regions are also discussed.

To study the plastic waste availability in the region, the types of plastic waste, plastic production, exports and waste handling data were collected and analysed. The data for plastics flows is based on publications with varying basis years (in the range of 2022 to 2023). As the information with the same basis year could not be attained, the flow from these publications is used and the analysis is based on this approximation. Plastics can be categorised as thermoplastics and thermosets, based on their thermophysical properties as shown in Table 53. Thermoplastics are plastics which becomes pliable at elevated temperature and solidifies upon cooling while thermosetting plastics (thermosets) are plastics which cannot be melted and re-shaped after they are cured. Understanding this categorisation is important because all the plastic waste cannot be chemically recycled using just one technology due to the differences in the thermophysical properties and based on the type of plastic waste, different chemical recycling technologies might be required. As thermosets cannot be melted again, they cannot be effectively used for pyrolysis or hydrothermal liquefaction while thermoplastics can become tacky in nature upon melting which can sometimes create challenges for gasification [193].

Table 53. Examples of thermoplastics and thermosets.

Note: In black thermoplastics with only carbon and hydrogen in molecular structure and in violet thermoplastics with other impurities like sulfur, chlorine and nitrogen.

THERMOPLASTICS	THERMOSETS
Acrylonitrile butadiene styrene	Cyanate esters
Nylon (Polyamide)	Polyester resin
Polyacrylic acids	Epoxy resin
Polybenzimidazole	Vulcanised rubber
Polycarbonate	Bakelite
Polyether ether ketone	Melamine resin
Polyether sulfone	Duroplast
Polyetherimide	Diallyl-phthalate
Polyethylene (UHMWPE, HDPE, MDPE, LDPE, LLDPE)	Epoxy novolac resins
Polylactic acid	Polyurethanes
Polymethyl methacrylate	Polyimides and bismaleimides
Polyoxymethylene	Urea-formaldehyde
Polyphenylene sulphide	Benzoxazines
Polypropylene	Furan resins
Polystyrene	Silicone resins
Polyethylene terephthalate (PET)	Thiolyte
Polytetrafluoroethylene (Teflon)	Vinyl ester



Polyvinyl chloride

Polyvinylidene fluoride

The purpose of the analysis was to get a snapshot of the plastic flows. Plastic consumption is included as packaging, building & construction, electrical & electronics, houseware, leisure & sports, agriculture, farming & gardening and others. The concept of stock is included in the Sankey diagram as accumulation and unknown, as they are not reported clearly in the references.

- **The Netherlands**

The plastic production, export, usage and waste recycling information for the Netherlands were collected from the 'Conversio' report "Substantiation of data for polymer production and processing in the Netherlands" and Circular Plastics NL report "Navigating Volumes and Value Chains Towards Circularity" with the basis year of 2022 elaborated for Netherlands Enterprise Agency (Rijksdienst voor Ondernemend Nederland, RVO) [194], [195]. The plastic waste incineration information was based on 2022 data from the Circular Plastics NL report "Navigating Volumes and Value Chains Towards Circularity" [195]. The plastic waste export information was based on the 2023 data from the Statista database "Plastic waste exports from the Netherlands in 2023, by destination" [196]. The data from these reports and databases were mapped and analysed to understand the plastic flow in the Netherlands. Due to data limitations, the information from these different studies with varying basis year is used and the potential error or discrepancy in the flows due to the differences in studies and basis years are not analysed in this study. The plastic production, export, usage and waste recycling information for the Netherlands were collected from the 'Conversio' report "Substantiation of data for polymer production and processing in the Netherlands" and Circular Plastics NL report "Navigating Volumes and Value Chains Towards Circularity" with the basis year of 2022 elaborated for Netherlands Enterprise Agency (Rijksdienst voor Ondernemend Nederland, RVO) [194], [195]. The plastic waste incineration information was based on 2022 data from the Circular Plastics NL report "Navigating Volumes and Value Chains Towards Circularity" [195]. The plastic waste export information was based on the 2023 data from the Statista database "Plastic waste exports from the Netherlands in 2023, by destination" [196]. The data from these reports and databases were mapped and analysed to understand the plastic flow in the Netherlands. Due to data limitations, the information from these different studies with varying basis year is used and the potential error or discrepancy in the flows due to the differences in studies and basis years are not analysed in this study.

The Netherlands produces around 6.7 Mio. t of raw plastic [194] as shown in Figure 23. About 17 % of plastics are produced from recycled plastic waste (i. e., mechanical recycling). Polyolefins like polyethylene and polypropylene account for about 47 % of the total produced plastics. In 2022, only 2.3 Mio. t of plastic [194] (in terms of plastic [194] (i. e., 34 % of the produced plastic) was processed, 1.95 Mio. t (i. e., 29 % of the produced plastic) used within the Netherlands out of the 6.7 Mio. t and the rest was exported. Thus, majority of the plastic production in the Netherlands is export oriented, which undermines the potential of chemical recycling. As of now, only 457 kt plastic waste is imported compared to the 4,805 kt plastic or polymer product export [194]. The major uses of plastics are packaging (41 % of total usage) and buildings & construction (26 % of total usage) [194]. As of now, only 457 kt plastic waste is imported compared to the 4,805 kt plastic or polymer product export [194]. The major uses of plastics are packaging (41 % of total usage) and buildings & construction (26 % of total usage) [194].

Around 1.95 Mio. t of plastic waste is consumed in the Netherlands and 86 % of the total plastic waste is thermoplastics [194]. The plastic waste can be further classified as pre-consumer waste and post-consumer. Pre-consumer plastic waste is easier to recycle than post-consumer plastic waste as it is purer and typically uncontaminated. Pre-consumer plastic waste is generated during manufacturing

from cuts and trimmings while post-consumer plastic waste comes from consumers after their end-of-life often in mixed and contaminated manner. Therefore, understanding this classification is important for realising the potential and challenges of chemical recycling. Based on the data, the pre-consumer plastic waste of 266 kt is recycled in the Netherlands. About 1,103 kt of the post-consumer plastic waste is collected and processed in the Netherlands [194], [195], [196], [197], [198]. The end-of-life waste disposal for PVC polymers is not well documented in the references and it is classified as unknown in this study. The collected plastic waste, (the thermoplastics and thermosets) are currently sent for recycling, incineration or export. Around 409 kt of plastic waste is recycled [194], 583 kt is incinerated [195] and 550 kt is accumulated (in stock) or exported [196] in the Netherlands. Around 1.95 Mio. t of plastic waste is consumed in the Netherlands and 86 % of the total plastic waste is thermoplastics [194]. The plastic waste can be further classified as pre-consumer waste and post-consumer. Pre-consumer plastic waste is easier to recycle than post-consumer plastic waste as it is purer and typically uncontaminated. Pre-consumer plastic waste is generated during manufacturing from cuts and trimmings while post-consumer plastic waste comes from consumers after their end-of-life often in mixed and contaminated manner. Therefore, understanding this classification is important for realising the potential and challenges of chemical recycling. Based on the data, the pre-consumer plastic waste of 266 kt is recycled in the Netherlands. About 1.103 kt of the post-consumer plastic waste is collected and processed in the Netherlands [194], [195], [196], [197], [198]. The end-of-life waste disposal for PVC polymers is not well documented in the references and it is classified as unknown in this study. The collected plastic waste, (the thermoplastics and thermosets) are currently sent for recycling, incineration or export. Around 409 kt of plastic waste is recycled [194], 583 kt is incinerated [195] and 550 kt is accumulated (in stock) or exported [196] in the Netherlands.

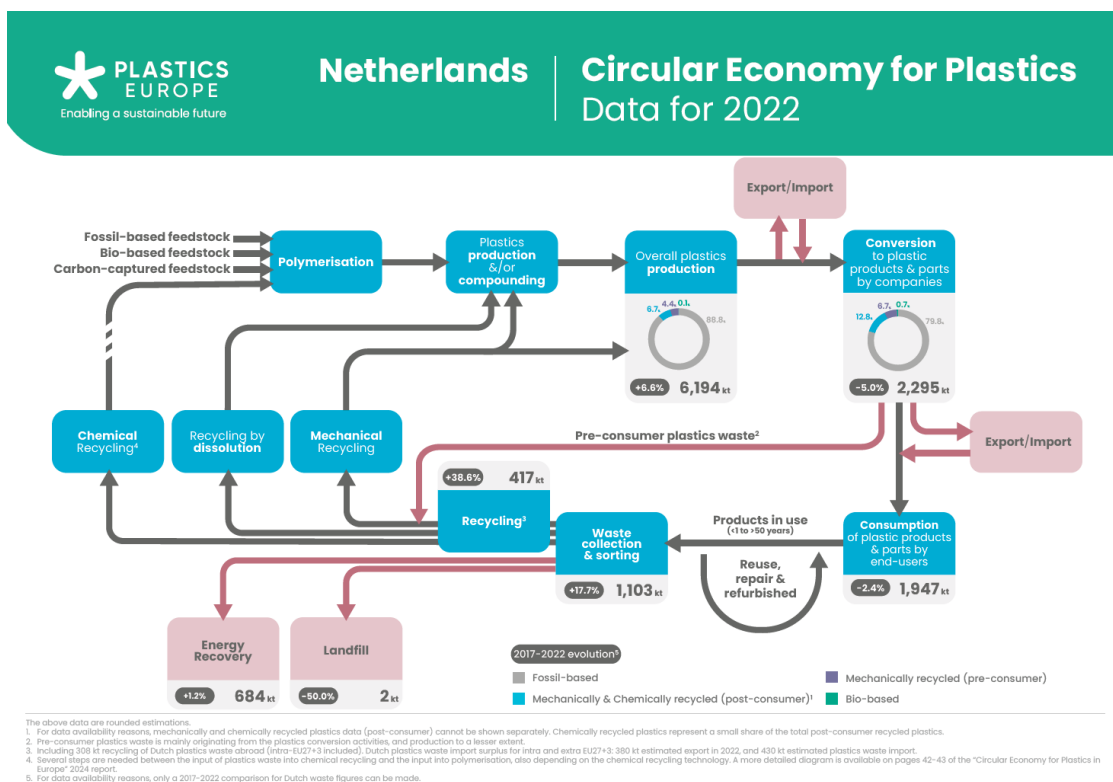

Figure 65. Plastic flow in the Netherlands as per Plastics Europe data for 2022 [99].

Figure 65 shows the plastic flow in the Netherlands as per Plastics Europe data for 2022 [99]. The comparison between Figure 23 and Figure 65, shows that the plastic flow data is similar with slight variations in energy recovery and waste export data. Figure 65 also provides better understanding of

the waste collection rate, which shows the actual potential of plastic waste is lower due to stockpile and uncollected waste.

The insights from the plastic flow analysis, including production, usage, and waste disposal, are Almost 65 % of the plastics produced in the Netherlands is exported to other countries as product. Leaving 35 % remaining with which the plastic recycling loop cannot be closed, unless we import plastic waste or equivalent pyrolysis oil. About 86 % of the plastic waste is thermoplastics while 14 % is thermosetting plastics in the Netherlands. About 23 % is PVC and thermosets, which cannot be used for pyrolysis. About 35 % plastic waste is already mechanically recycled. One of the aspects which cannot be seen in the Sankey diagram is the quality of the collected plastic waste. Currently, plastic waste which cannot be sorted and cleaned is sent to incineration. Creation of proper sorting mechanism and policies, to prevent the contamination and export of plastic waste, will be critical for encouraging chemical recycling facilities in the Netherlands.

- **Germany**

The plastic production, export, usage and waste recycling information for Germany were collected from the 'Conversio' report "Conversio Market & Strategy GmbH. Stoffstrombild Kunststoffe in Deutschland 2021: Zahlen Und Fakten Zum Lebensweg von Kunststoffen", with 2023 as base year [96]. The plastic waste export information was based on the 2024 data from the Basel action network report "Germany export data annual summary" [199]. The data from these reports and databases were mapped and analysed to understand the plastic flow in Germany. Due to data limitations, the information from these different studies with varying basis year is used and the potential error or discrepancy in the flows due to the differences in studies and basis years are not analysed in this study. The plastic production, export, usage and waste recycling information for Germany were collected from the 'Conversio' report "Conversio Market & Strategy GmbH. Stoffstrombild Kunststoffe in Deutschland 2021: Zahlen Und Fakten Zum Lebensweg von Kunststoffen", with 2023 as base year [96]. The plastic waste export information was based on the 2024 data from the Basel action network report "Germany export data annual summary" [199]. The data from these reports and databases were mapped and analysed to understand the plastic flow in Germany. Due to data limitations, the information from these different studies with varying basis year is used and the potential error or discrepancy in the flows due to the differences in studies and basis years are not analysed in this study.

Germany produces around 12.85 Mio. t of plastic as shown in Figure 24. About 19 % of plastics are produced from recycled plastic waste. Polyolefins like polyethylene and polypropylene account for about 44 % of the total produced plastics. In 2023, only 1.6 Mio. t of raw plastic (i. e., 12 % of the produced plastic) is exported from Germany out of the 12.85 Mio. t and the rest is used and further converted locally. The major share of usage of plastics is for packaging (27 % of total usage), buildings & construction (21 % of total usage), automotive (9 % of total usage) and electrical & electronics (9 % of total usage). There is a high mismatch in the data regarding the quantity of plastic produced and plastic waste collected in Germany. This could be due to Germany being a product export-oriented country, majority of the plastic products in Germany might be sold abroad, which makes recycling highly challenging. As of now, 6,348 kt plastic is collected in Germany while about 4,902 kt plastic is unknown or accumulated or in export products and only 236 kt plastic waste is imported.

Thus, around 6.3 Mio. t of plastic waste are collected in Germany and 91 % of the total plastic waste is thermoplastics. It is assumed that all the collected non-recycled fraction of thermosets are incinerated, while the collected non-recycled fraction of thermoplastics is incinerated, landfilled, or exported. The end-of-life waste disposal for PVC polymers is not well documented in the references and it is classified as unknown in this study. For analysing, the olefin and aromatic production potential from plastic waste in Germany, it can be assumed that all the non-recycled thermosets (like PUR, PET, PA, ABS, SAN, biobased, PMMA and other thermosets) are available for gasification due to its incompatibility with

pyrolysis. While all the non-recycled thermoplastics (like PE, PP, EPS, PS and other thermoplastics), except PVC, can be assumed to be available for pyrolysis. The chemical recycling of thermoplastics like PVC is recommended to be considered standalone due to the complexity of dealing with chlorides, fluorides and sulfides in the streams.

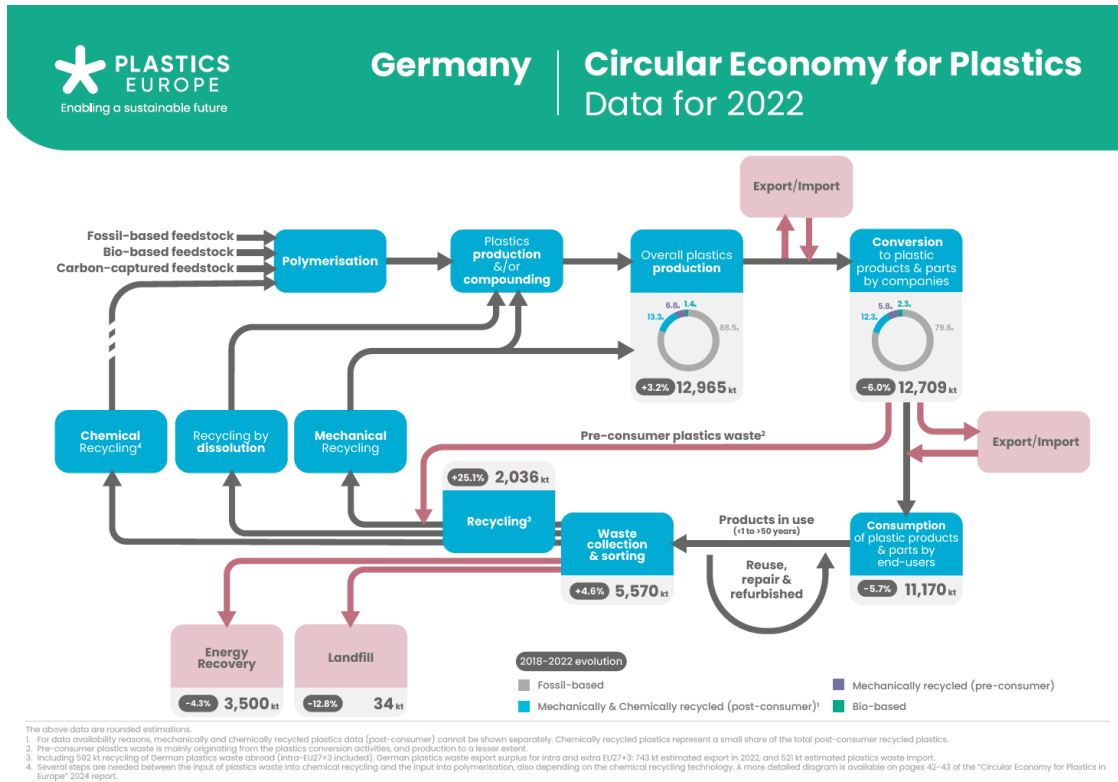

Figure 66. Plastic flow in Germany as per Plastics Europe data for 2022 [99].

Figure 66 shows the plastic flow in Germany as per Plastics Europe data for 2022 [99]. The comparison between Figure 24 and Figure 66 shows that the plastic flow data is similar with slight variations in energy recovery and waste export data. Figure 66 also provides better understanding of the waste collection rate, which shows the actual potential of plastic waste is lower due to stockpile and uncollected waste.

• **Belgium**

The plastic production, export, usage and waste recycling information for Belgium were collected from the 'Plastics Europe report "Circular Economy for Plastics Data for 2022 Belgium"' with the basis year of 2022 [99]. The plastic waste export information was based on the 2023 data from the OVAM report "Plastics Implementation Plan 2020-2025" [100]. The data from these reports and databases were mapped and analysed to understand the plastic flow in Belgium (Figure 25). Due to data limitations, the information from these different studies with varying basis year is used and the potential error or discrepancy in the flows due to the differences in studies and basis years are not analysed in this study.

Belgium produces around 7.3 Mt of plastic as shown in Figure 67. About 5 % of plastic is produced from recycled plastic waste. In 2022, only about 1.2 Mt of raw plastic (i. e., 16 % of the produced plastic) is consumed within Belgium out of the 7.3 Mt and the rest is exported as polymer or products. The major share of the usage of plastics is for packaging (28 % of total usage), buildings & construction (22 % of total usage), automotive (9 % of total usage) and electrical & electronics (9 % of total usage). As majority

of the plastics and plastic products in Belgium are sold abroad, recycling is highly challenging. The reference did not mention the type of plastic production or waste as detailed in the above cases for the Netherlands or Germany. For further analysis, it can be assumed that the plastic waste fraction of Belgium is equivalent to that of Germany due to the similarity in the fraction of plastic used in the different sectors like packaging, building & construction, automotive, electrical & electronics etc. According to Plastics Europe [99], only about 0.6 Mio. t of plastic waste is collected compared to the 1.2 Mio. t of plastic used in Belgium. 60 % of collected waste is incinerated, 39 % is recycled and 2 % is landfilled. The plastic waste export in Belgium is estimated to be around 270 kt [87] and about 100-300 kt plastic waste is not well documented in the references and it is classified as unknown in this study.

The details regarding the type of plastic is not available in the references and these aspects are not analysed further in this study.

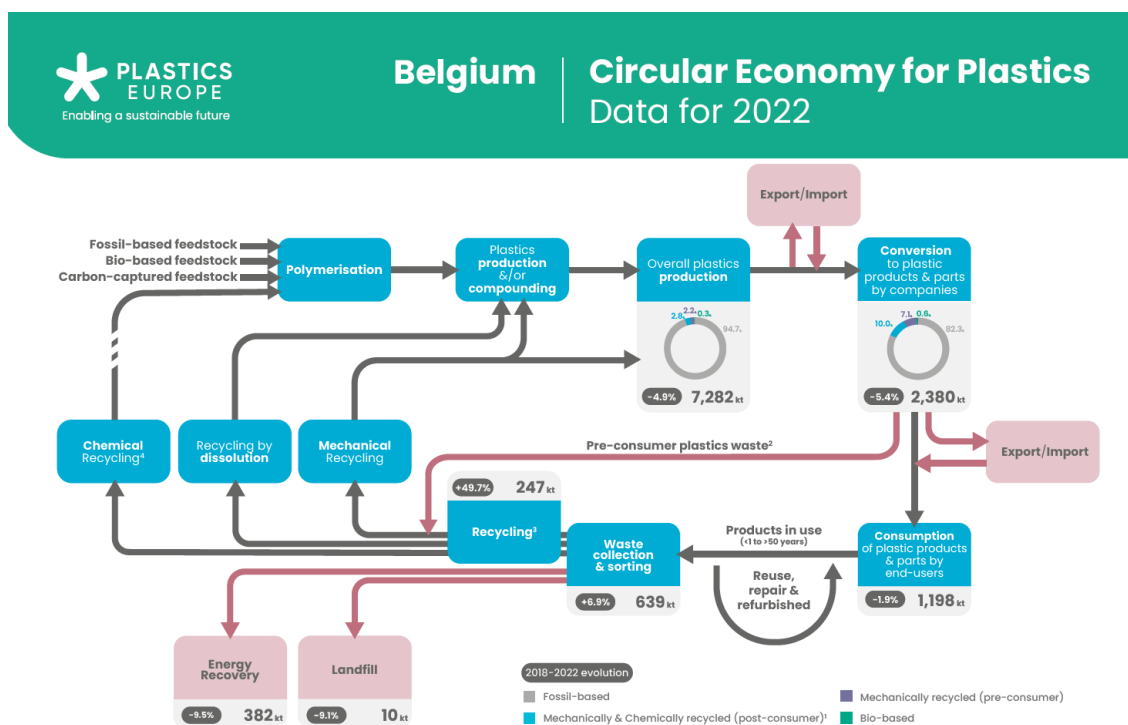

Figure 67. Plastic flow in Belgium as per Plastics Europe data for 2022 [99].

Figure 67 shows the plastic flow in Belgium as per Plastics Europe data for 2022 [99]. The comparison between Figure 25 and Figure 67 shows that the plastic flow data is similar with slight variations in energy recovery and waste export data. Figure 67 also provides better understanding of the waste collection rate, which shows the actual potential of plastic waste (waste is lower due to stockpile and uncollected waste).

ANNEX I. FUTURE PERSPECTIVE OF INDUSTRY STAKEHOLDERS

Strategies developed at the SWOT Workshop

Based on SWOT factors describing the current state of the TCR (see Chapter 2.4 *Stakeholder perspectives on the current state of the TCR*, p. 31), the industry stakeholders participating in the first stakeholder workshop developed possible future strategies. For the detailed methodology see Chapter *SWOT Analysis*, Annex A, p.7. The following section introduces the – according to stakeholders – most relevant strategies and discusses their impact on the chemical industry in the TCR and its competitiveness.

- **Security of Supply**

The favoured strategy in the field *Security of Supply* focused on how to take advantage of the region's high infrastructure density to repurpose the existing infrastructure. This approach involves incremental changes that allow to maintain maximum operability throughout the transition, for instance, by making use of redundancies (e. g. natural gas (NG)/H₂ systems) and employing new or adapted barges, vessels and wagons to transport alternative feedstock. A coordinated effort by regulators and policymakers to harmonise standards and regulations could help avoiding additional costs that could arise if multiple stakeholders implemented independently individual solutions. Synergies, like joint maintenance of infrastructures and coordinated pipeline construction and installation, were highlighted as another effective measure to reduce costs.

Three additional strategies within *Security of Supply* focused on strengthening the resilience, defined as ability to deal with an external shock. The main strategy to mitigate high energy and feedstock prices is the diversification of supply chains and markets. A measure that policymakers could support by, for example clarifying regulations regarding the use of various feedstocks. This is particularly relevant for plastic waste, where the absence of a clear legal framework continues to prevent companies from investing into accessing this alternative feedstock.

- **Alternative Feedstocks**

This last-mentioned issue was also discussed at the strategy development in the field of *Alternative Feedstocks*. To enable the development of new sustainable business models, it is essential to establish a framework that creates a functioning market, along with clear certification schemes and flexible allocation mechanisms. Dedicated market pull instruments could help create starting points such as a lead market, from which synergies would emerge and further development be facilitated. Associations and policymakers could coordinate an overarching European effort and establish simple, positive incentive structures. In addition to penalising emissions, a reward system for emission avoidance could be introduced, since increasing penalties alone would only intensify pressure on companies and potentially drive investments elsewhere. For this purpose, every substituted unit of fossil feedstock with circular or renewable feedstock could, for instance, be rewarded with a premium to offset additional costs linked to higher feedstock prices or transformation-related expenditures.

- **Business Development**

In the field of *Business Development*, stakeholders emphasised across all workshop discussions that dedicated market pull instruments for sustainable products are the most critical prerequisites. One of the strategies dealt with overcoming the challenges of transforming an optimised system in order to enhance its resilience. Policymakers could play a crucial role here by (i) introducing fast-track permitting and (ii) offering financial incentives through a simplified subsidy mechanism governed by transparent pre-determined and fair rules. Associations could support the development of this subsidy system by actively engaging policymakers on the sector's critical needs, The 'Antwerp Declaration' is a positive

example [200]. As a potential de-risking approach companies themselves could consider offering shares of final profits from successful projects in return for initial governmental financial support.

Another strategy in the field of *Business Development* focusses on how the high level of industrial integration and cooperation can be leveraged to enhance resilience. The suggestion is to establish a carbon or element management entity. At the site level, a similar initiative called the 'Chemelot Sustainability Experts', is already underway at the Chemelot site in the Netherlands and could serve as an example for other sites developing overarching, integrated carbon management strategies. Moreover, this concept can be upscaled to a trans-national level, with the TCR serving as a role model to pilot such an initiative with a few selected projects. Concrete objectives could include the accelerating of permitting processes and designing proposals for cross-border regulatory alignment, which would facilitate the realisation of future projects.

It is noteworthy that 'threats' represented the longest list of SWOT factors, yet none of the Strengths-Threats (S-T) or Weaknesses-Threats (W-T) confrontations achieved a correlation strong enough to be selected for the strategy development. This is mainly due to the methodology used: The selection of factors for the strategy development was based on the strength of their correlation, and the opportunities correlated much stronger with the Strengths and Weaknesses than the threats. It doesn't mean that threats are less important. The absence of strong S-T correlations might in fact indicate that the available strengths of the TCR are not believed to adequately counter some of the partly existential threats identified in Chapter 2.4 *Stakeholder perspectives on the current state of the TCR*, p. 31. This underscores the necessity of adequate framework conditions to support the industry. At the same time, it is striking that the majority of all developed strategies focused on taking advantage of the opportunity to become more resilient. This clearly shows that the recent crisis has raised awareness among companies of their current lack of resilience and the urgent need to improve it.

Proposed actions derived from the SWOT strategy development

The premise for the strategy development was to allocate concrete actions to specific stakeholder groups, i. e. policy makers, associations and society, and the companies themselves. Based on all strategies developed, a set of specific recommendations was formulated. The following section outlines those recommendations considered the most important/urgent, i. e. those mentioned in several strategies and those associated with the four top-rated strategies. An excerpt of the actions considered most important by the participants is shown in Figure 68. These actions are designed to help the industry successfully navigate the energy crisis and ongoing transformation by: facilitating project implementation, mainly infrastructure-related, through fast-track permitting, ensuring profitable production by enabling viable business cases, and fostering collaboration between industry and academia to, for example, increase process efficiency and improve access to alternative feedstocks for the chemical sector.

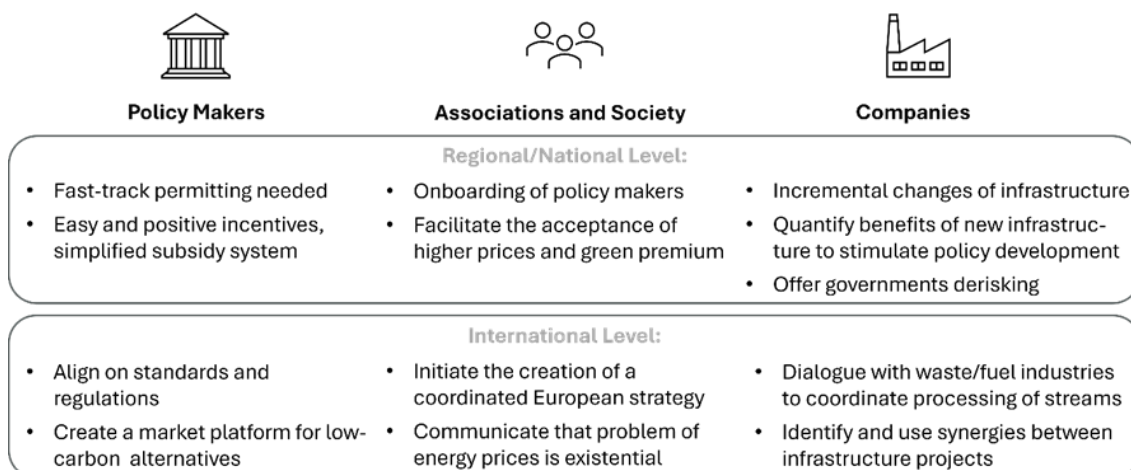

Figure 68. Most important actions, extracted from the developed strategies and assigned to the responsible stakeholder groups.

One central theme is the urgent need for the industry to strengthen its resilience. To this end, the companies are encouraged to foster collaboration with academia and other industries to improve the accessibility of alternative feedstocks, to optimise their production processes and to facilitate diversification.

Support from society and policymakers is considered essential and should focus on:

- Tackling high energy prices and other supply side challenges
- Coordinated infrastructure development and fast-track permitting
- Establishing a clear legal framework for carbon management and recycling, which for instance allows for a flexible allocation (= mass balance approach) of utilized recycled feedstock in established processes
- Introducing a simplified subsidy system with transparent, pre-determined and fair rules. This may for instance include an adequate flow-back of financial resources (e. g. ETS revenues) to the chemical industry, specifically to projects serving the purpose of resilience and sustainable production.

Importantly, these measures must work hand in hand. Subsidies can reduce CAPEX for project realisation, but final investment decisions will only be made if long-term perspectives exist, either through (i) the ability to sell products competitively within existing markets by maintaining affordable operating expenditures (OPEX), or (ii) the existence of alternative markets where low-emission products can be sold profitably.